



Rettungsdatenblätter Volkswagen

Modellübersicht

Modell- bezeichnung

Modell- zyklus

Modell- bezeichnung

Modell- zyklus

A

- **Amarok** (4-Türer) ab 2010
- Amarok (2-Türer) ab 2011

B

- **Beetle** 1998 - 2011
- Beetle ab 2011
- Beetle (Cabrio) ab 2003
- **Bora** (Limousine) 1998 - 2005
- Bora (Variant) 1999 - 2005

C

- **Caddy** (Kombi) 1996 - 2003
- Caddy (Pickup) 1997 - 2002
- Caddy (Kombi) ab 2004
- Caddy (Kombi EcoFuel) ab 2006
- Caddy ab 2010
- Caddy (EcoFuel) ab 2010
- Caddy (BiFuel) ab 2010
- Caddy Maxi 2007 - 2010
- Caddy Maxi (EcoFuel) 2007 - 2010
- Caddy Maxi ab 2010
- Caddy Maxi (EcoFuel) ab 2010
- Caddy Maxi (BiFuel) ab 2010
- **Corrado** 1988 - 1995
- **Crafter** ab 2006
- Crafter Fahrgest. (2-Türer) ab 2006
- Crafter Fahrgest. (4-Türer) ab 2006

E

- **Eos** ab 2006

F

- **Fox** ab 2005

G

- **Golf 3** (3-Türer) 1991 - 1997
- Golf 3 (5-Türer) 1991 - 1997
- Golf 3 (Variant) 1993 - 1999
- Golf 3 (Cabrio) 1993 - 1998

G

- **Golf 4** (3-Türer) 1997 - 2003
- Golf 4 (5-Türer) 1997 - 2003
- Golf 4 (Variant) 1999 - 2003
- Golf 4 (Cabrio) 1998 - 2002
- Golf 4 (Variant BiFuel) 2003 - 2006
- **Golf 5** (3-Türer) 2003 - 2008
- Golf 5 (5-Türer) 2003 - 2008
- Golf 5 Plus 2005 - 2009
- Golf 5 (Variant) 2006 - 2009
- **Golf 6** (3-Türer) ab 2008
- Golf 6 (5-Türer) ab 2008
- Golf 6 (3-Türer BiFuel) ab 2009
- Golf 6 (5-Türer BiFuel) ab 2009
- Golf 6 (Variant) ab 2009
- Golf 6 Plus ab 2009
- Golf 6 Plus (BiFuel) ab 2009
- Golf 6 (Cabrio) ab 2011
- **Golf 7** (3-Türer) ab 2012
- Golf 7 (5-Türer) ab 2012

J

- **Jetta** 2005 - 2010
- Jetta ab 2010

L

- **Lupo** 1998 - 2005



Rettungsdatenblätter Volkswagen

Modellübersicht (Fortsetzung)

Modell- bezeichnung

Modell- zyklus

Modell- bezeichnung

Modell- zyklus

P

- **Passat B4** (Limousine) 1993 - 1996
Passat B4 (Variant) 1993 - 1997
- **Passat B5** (Limousine) 1996 - 2005
Passat B5 (Variant) 1997 - 2005
- **Passat B6** (Limousine) 2005 - 2010
Passat B6 (Variant) ab 2005
Passat B6 (Lim. EcoFuel) ab 2009
Passat B6 (Var. EcoFuel) ab 2009
- **Passat B7** (Limousine) ab 2010
Passat B7 (Variant) ab 2010
Passat B7 (Lim. EcoFuel) ab 2010
Passat B7 (Var. EcoFuel) ab 2010
- **Passat CC** ab 2008
- **Phaeton** ab 2002
- **Polo A03** (3-Türer) 1994 - 2001
Polo A03 (5-Türer) 1994 - 2001
Polo A03 (Variant) 1994 - 2001
Polo A03 (Stufenheck) 1994 - 2001
- **Polo A04** (3-Türer) 2001 - 2009
Polo A04 (5-Türer) 2001 - 2009
Polo A04 (Stufenheck) 2001 - 2009
- **Polo A05** (3-Türer) ab 2009
Polo A05 (5-Türer) ab 2009
Polo A05 (3-Türer BiFuel) ab 2009
Polo A05 (5-Türer BiFuel) ab 2009

S

- **Scirocco** ab 2008
- **Sharan** 1995 - 2010
Sharan (BiFuel) ab 2006
Sharan ab 2010

T

- **Tiguan** ab 2007
- **Touareg** 2002 - 2010
Touareg ab 2010
Touareg Hybrid ab 2010
- **Touran** 2003 - 2006
Touran (EcoFuel) 2005 - 2006
Touran 2006 - 2010
Touran (EcoFuel) 2006 - 2010
Touran 5-Sitzer ab 2010
Touran 7-Sitzer ab 2010
Touran 5-Sitzer (EcoFuel) ab 2010
Touran 7-Sitzer (EcoFuel) ab 2010
- **Transporter LT2** 1996 - 2006
Tr. LT2 Fahrgest. 2-Türer 1996 - 2006
Tr. LT2 Fahrgest. 4-Türer 1996 - 2006
- **Transporter T4** 1991 - 2003
Tr. T4 Fahrgest. 2-Türer 1991 - 2003
Tr. T4 Fahrgest. 4-Türer 1991 - 2003
- **Transporter T5** 2003 - 2009
Tr. T5 Fahrgest. 2-Türer 2003 - 2009
Tr. T5 Fahrgest. 4-Türer 2003 - 2009
Tr. T5 California 2003 - 2009
Transporter T5 ab 2010
Tr. T5 Fahrgest. 2-Türer ab 2010
Tr. T5 Fahrgest. 4-Türer ab 2010
Tr. T5 California ab 2010

U

- **up!** (3-Türer) ab 2011
- **up!** (5-Türer) ab 2011

V

- **Vento** 1992 - 1998



Hinweis

In den Rettungsdatenblättern ist immer die maximal mögliche Ausstattung eines Fahrzeuges gemäß der von Volkswagen vorgesehenen Ausstattungsvarianten eines Modells abgebildet.

Rechtlicher Hinweis:

Diese Rettungsdatenblätter wurden ausschließlich für Rettungskräfte erstellt, die über eine spezielle Ausbildung auf dem Gebiet der technischen Hilfeleistung nach Verkehrsunfällen verfügen und damit die in diesen Datenblättern beschriebenen Tätigkeiten ausführen können. Ferner enthalten die Rettungsdatenblätter Informationen über Fahrzeuge, die zum Verkauf in der Europäischen Union bestimmt sind. Die Rettungsdatenblätter enthalten hingegen keine Informationen über Fahrzeuge, die zum Verkauf außerhalb der Europäischen Union bestimmt sind. Spezifikationen und Sonderausstattungen der Volkswagen Fahrzeuge sowie das Fahrzeugangebot der Volkswagen Aktiengesellschaft unterliegen stetig etwaigen Änderungen. Daher behält sich Volkswagen inhaltliche Anpassungen bzw. Änderungen an den Rettungsdatenblättern jederzeit ausdrücklich vor.

Beachten Sie bitte:

Die in den Rettungsdatenblättern enthaltenen Informationen sind nicht für Endkunden und ebenfalls nicht für Werkstätten und Händler bestimmt. Endkunden können den Bordbüchern ihres jeweiligen Fahrzeuges der Volkswagen AG Informationen zu den Funktionen ihres Fahrzeuges sowie wichtige Sicherheitshinweise zur Fahrzeug- und Insassensicherheit entnehmen. Werkstätten und Händler erhalten Service- und Reparaturinformationen über die ihnen bekannten Bezugsquellen.

Einen allgemeinen Teil mit Hinweisen zur technischen Hilfeleistung finden Sie in den Rettungsleitfäden „Hinweise zur Unfallrettung aus verunfallten Fahrzeugen der Volkswagen AG mit Sicherheitssystemen“ (Artikel-Nr. 001.2200.50.00) und „Hinweise zur Unfallrettung aus verunfallten Fahrzeugen der Volkswagen AG mit alternativen Antrieben“ (Artikel-Nr. 000.2200.56.00). Die Rettungsdatenblätter sind in interaktiver Form auch in der Datenbank „Crash Recovery System“ enthalten. Weitere Informationen zu dieser Datenbank erhalten Sie unter www.moditech.com.

(Stand: November 2011)

Artikelnummer: 002.2200.51.00



Rettungsdatenblätter Volkswagen

Typbezeichnungen in numerischer Reihenfolge

Typ- bezeichnung

Modell- bezeichnung

1

- **13** Scirocco
- **1E** Golf 3 (Cabrio)
- **1F** Eos
- **1G** Jetta
- **1H** Golf 3
- **1J** Golf 4
Golf 4 (Variant)
Bora
Bora (Variant)
- **1K** Golf 5
Golf 6
- **1KM** Golf 6 (Variant)
- **1KP** Golf 5 Plus
Golf 6 Plus
- **1T** Touran
- **1T0** Touran (ab 2010)
- **1Y** Beetle (Cabrio)

2

- **2DM** Transporter LT2
- **2EC** Crafter
- **2K** Caddy

3

- **35** Passat B5 (Limousine)
Passat B5 (Variant)
- **3A** Passat B4 (Limousine)
Passat B4 (Variant)
- **3C** Passat B6 (Limousine)
Passat B6 (Variant)
- **3CC** Passat CC
- **3D** Phaeton

Typ- bezeichnung

Modell- bezeichnung

5

- **53** Corrado
- **5N** Tiguan
- **5Z** Fox

6

- **6E(S)** Lupo (3l)
- **6N** Polo A03
Polo A03 (Variant)
Polo A03 (Stufenheck)
- **6R** Polo A05
- **6X** Lupo GTI

7

- **7D** Transporter T4
- **7H** Transporter T5
- **7J** Transporter T5 (Pritsche)
- **7L** Touareg
- **7M** Sharan
- **7P** Touareg (ab 2010)

9

- **9C** Beetle
- **9N** Polo A04
- **9U** Caddy Pickup







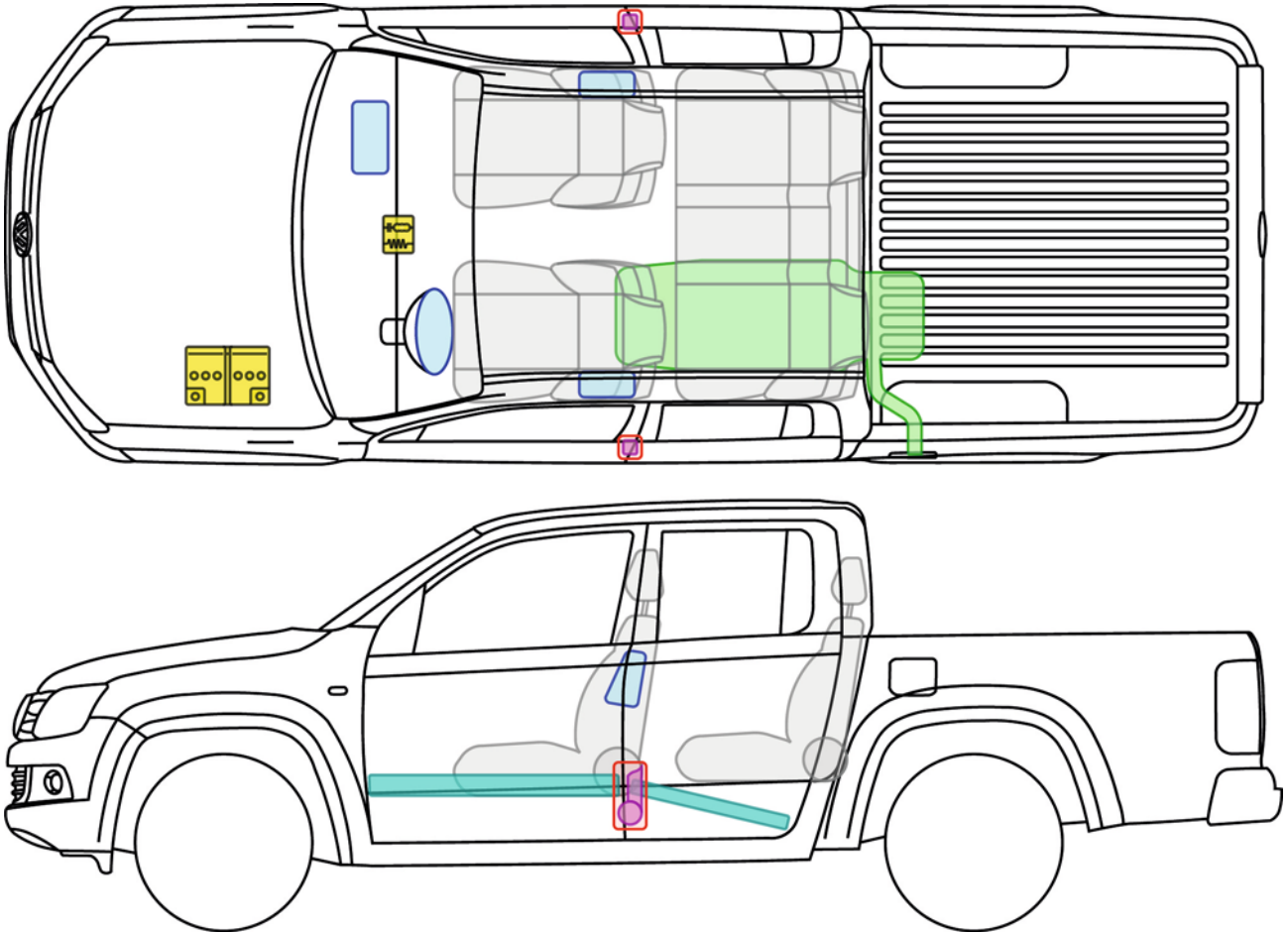

Amarok

(4-Türer, ab 2010)

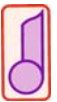

Legende

	Airbag		Karosserie-Verstärkung		Steuergerät	
					12 V-Batterie	
	Gurtstraffer				Kraftstofftank	







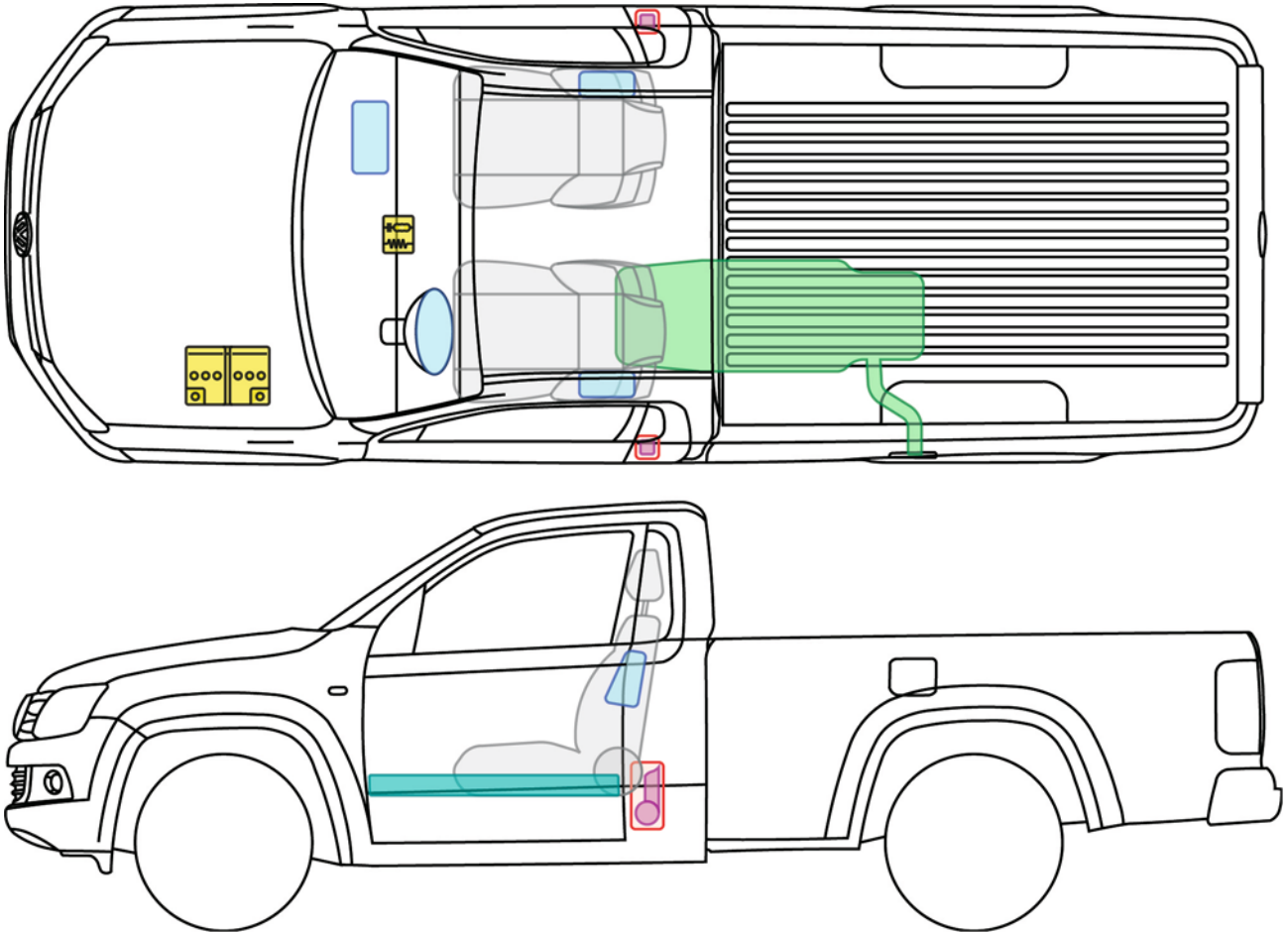

Amarok

(2-Türer, ab 2011)

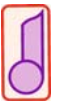

Legende

	Airbag		Karosserie-Verstärkung		Steuergerät
					12 V-Batterie
	Gurtstraffer				Kraftstofftank







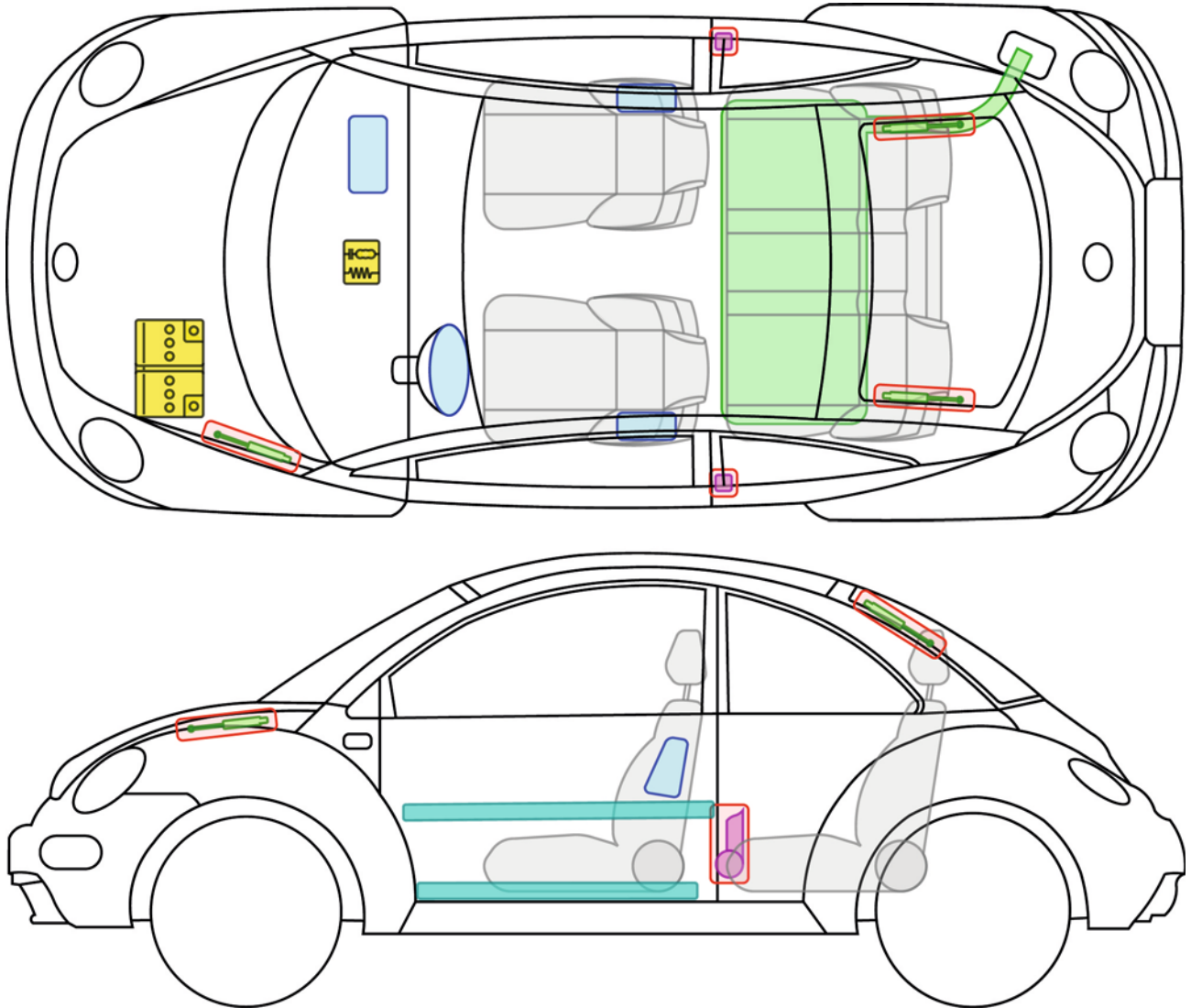

Beetle

(1998-2011)

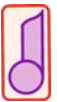

Legende

	Airbag		Karosserie-Verstärkung		Steuergerät
					12 V-Batterie
	Gurtstraffer		Gasdruck-dämpfer		Kraftstofftank







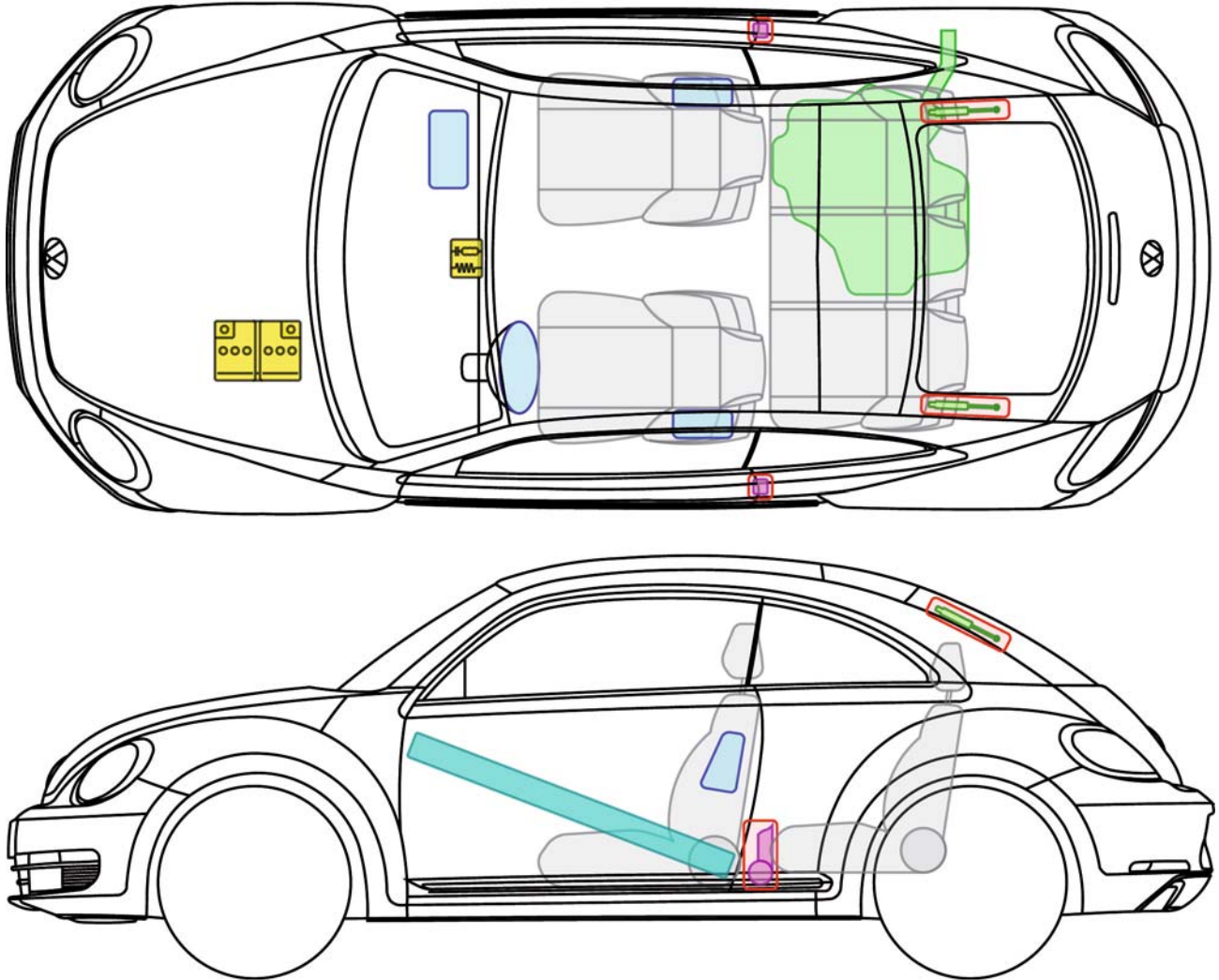

Beetle

(ab 2011)



Legende

	Airbag		Karosserie-Verstärkung		Steuergerät
					12 V-Batterie
	Gurtstraffer		Gasdruck-dämpfer		Kraftstofftank







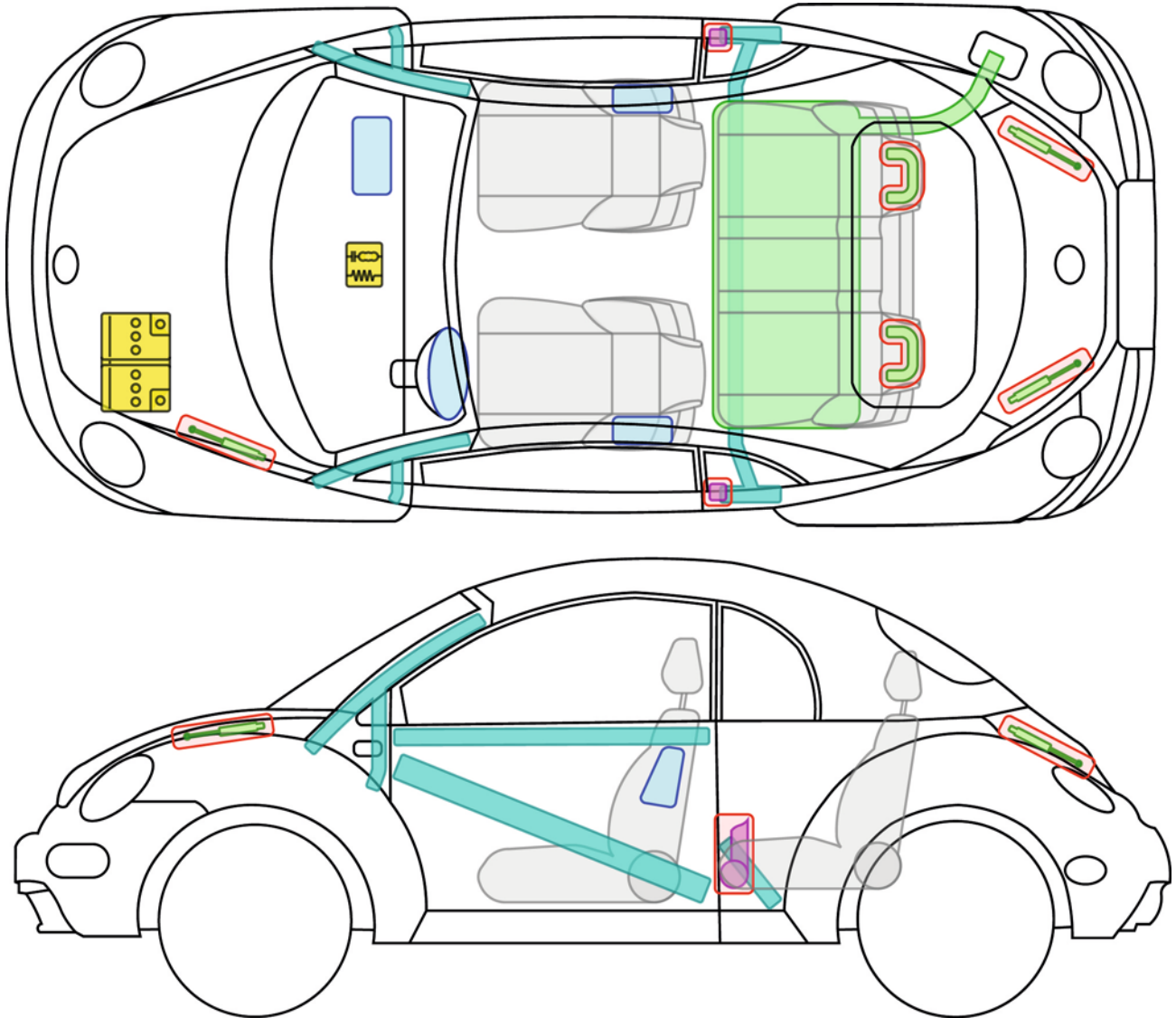

Beetle

(Cabrio, ab 2003)

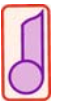

Legende

	Airbag		Karosserie-Verstärkung		Steuergerät
			Überroll-schutz		12 V-Batterie
	Gurtstraffer		Gasdruck-dämpfer		Kraftstofftank







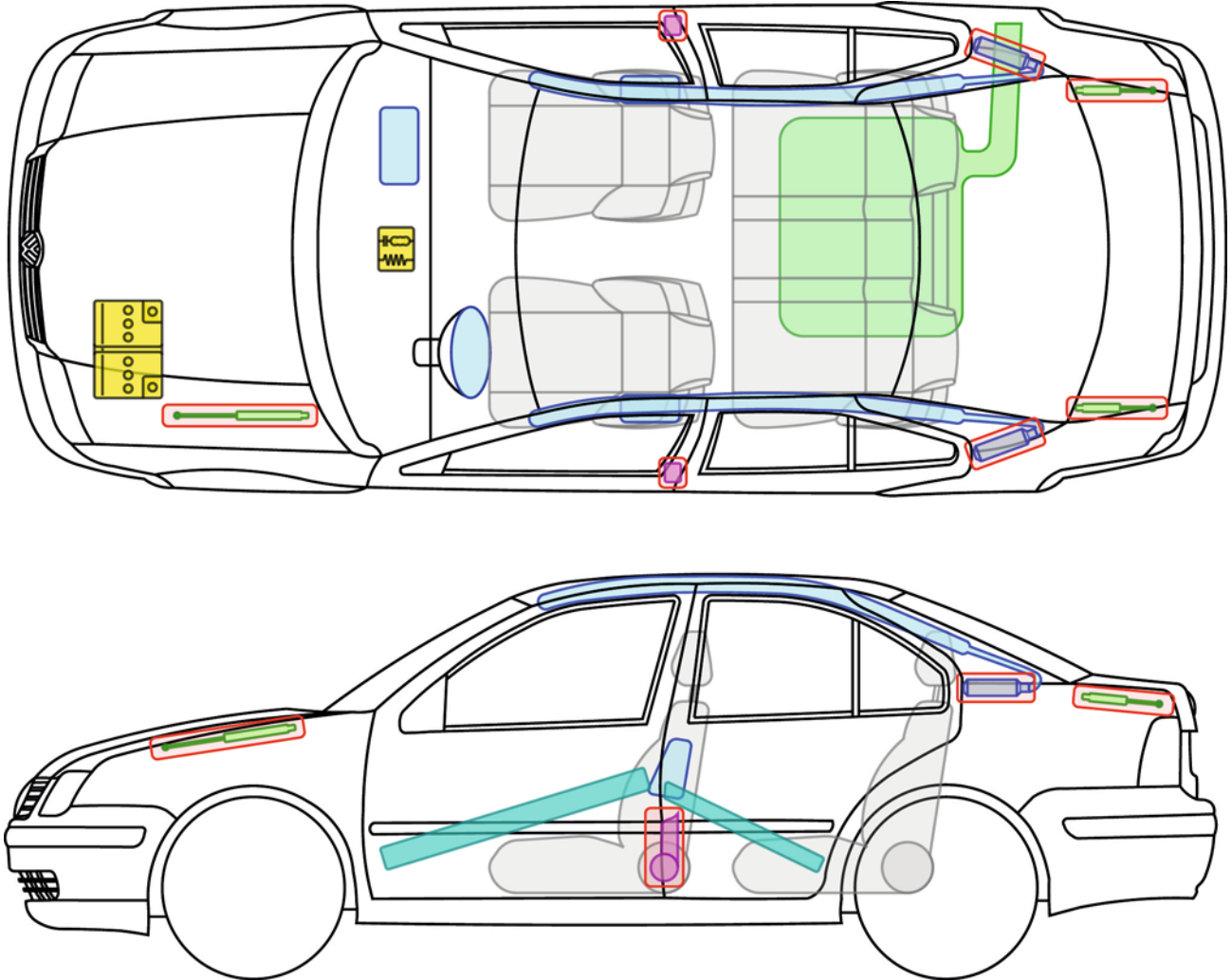



Bora

(Limousine, 1998 - 2005)



Legende

	Airbag		Karosserie-Verstärkung		Steuergerät	
	Gas-generator				12 V-Batterie	
	Gurtstraffer		Gasdruck-dämpfer		Kraftstofftank	







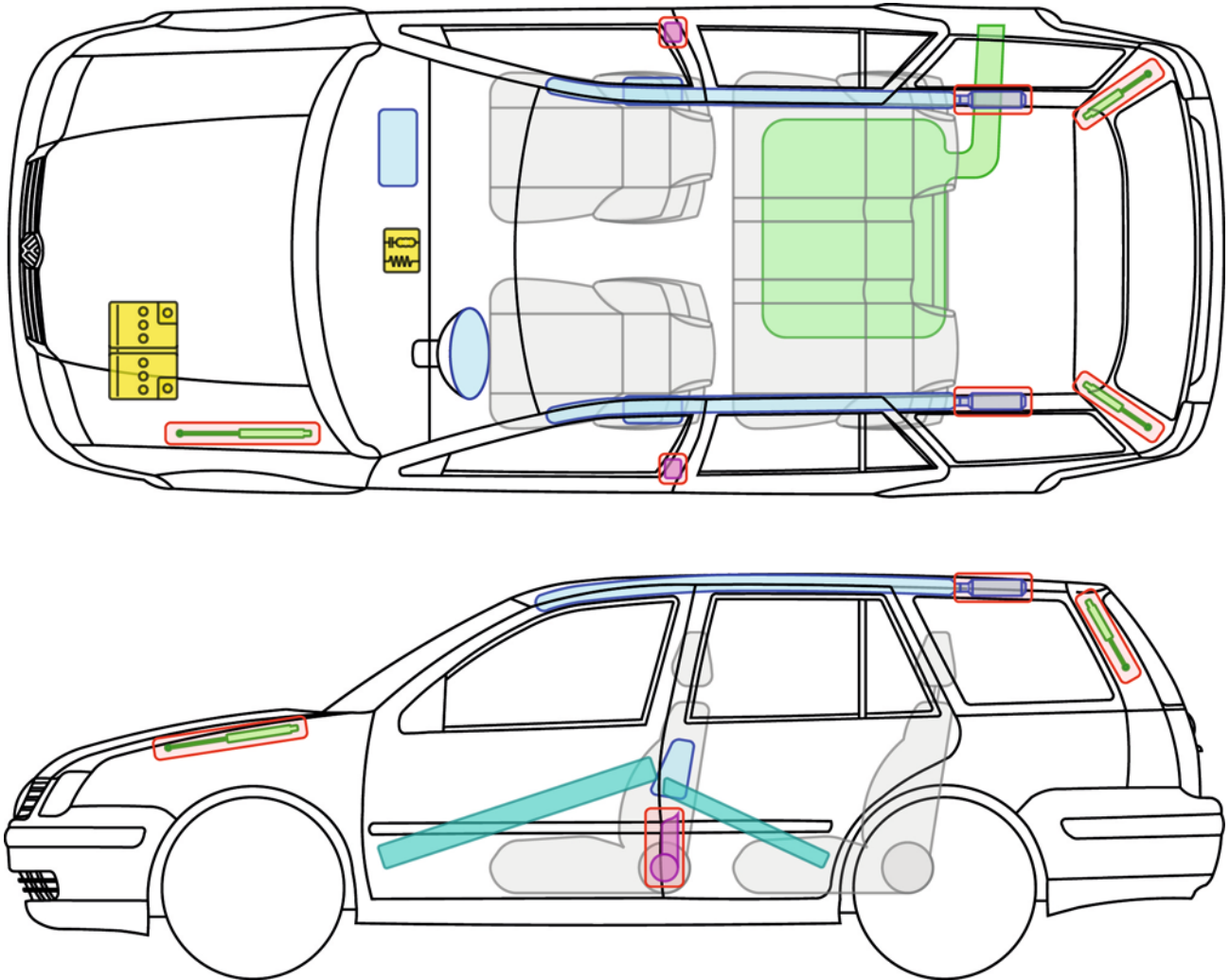



Bora

(Variant, 1999 - 2005)



Legende

	Airbag		Karosserie-Verstärkung		Steuergerät
	Gas-generator				12 V-Batterie
	Gurtstraffer		Gasdruck-dämpfer		Kraftstofftank



Caddy

(Kombi, 1996 - 2003)

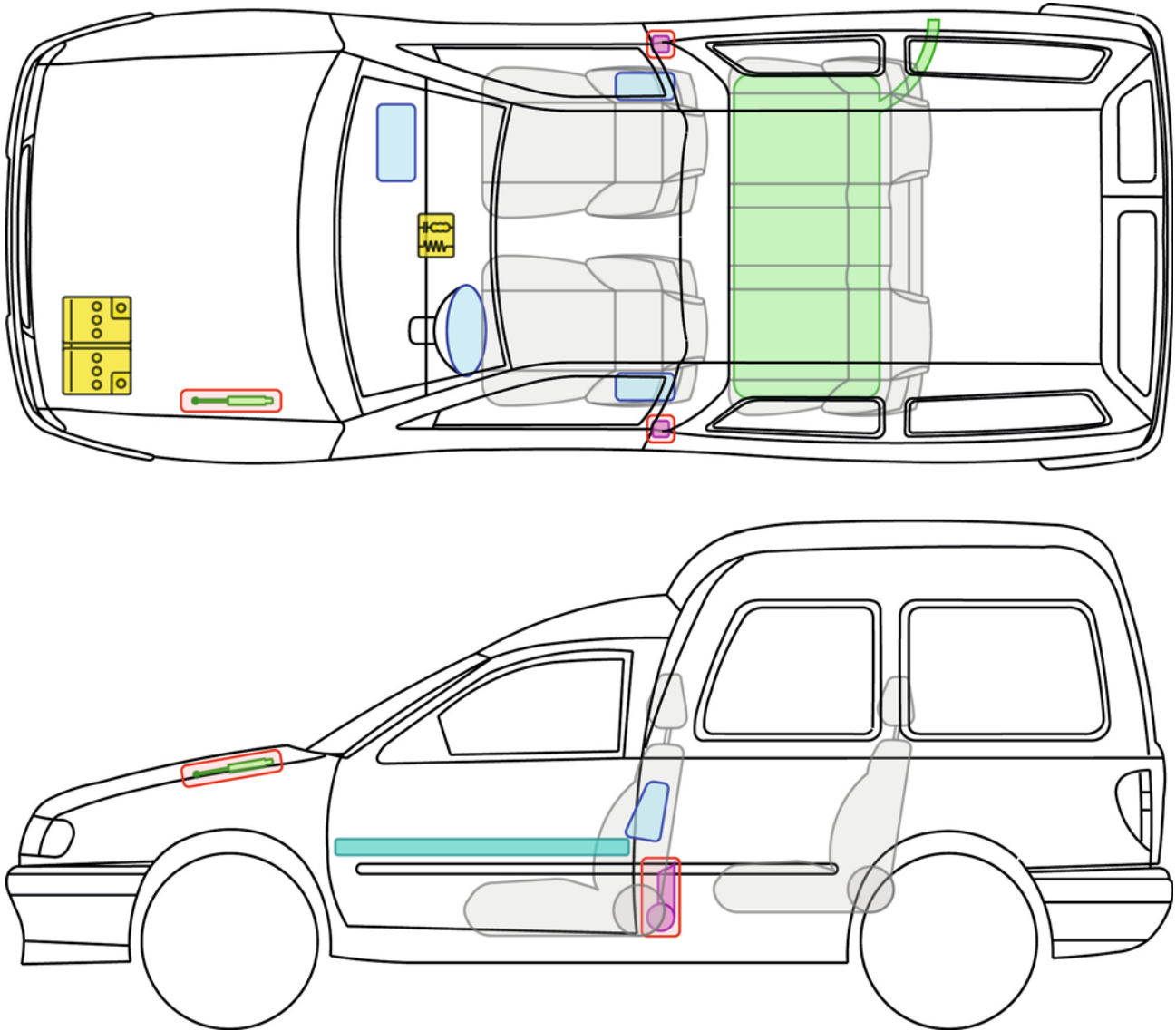

Legende

	Airbag		Karosserie-Verstärkung		Steuergerät
					12V-Batterie
	Gurtstraffer		Gasdruck-dämpfer		Kraftstofftank







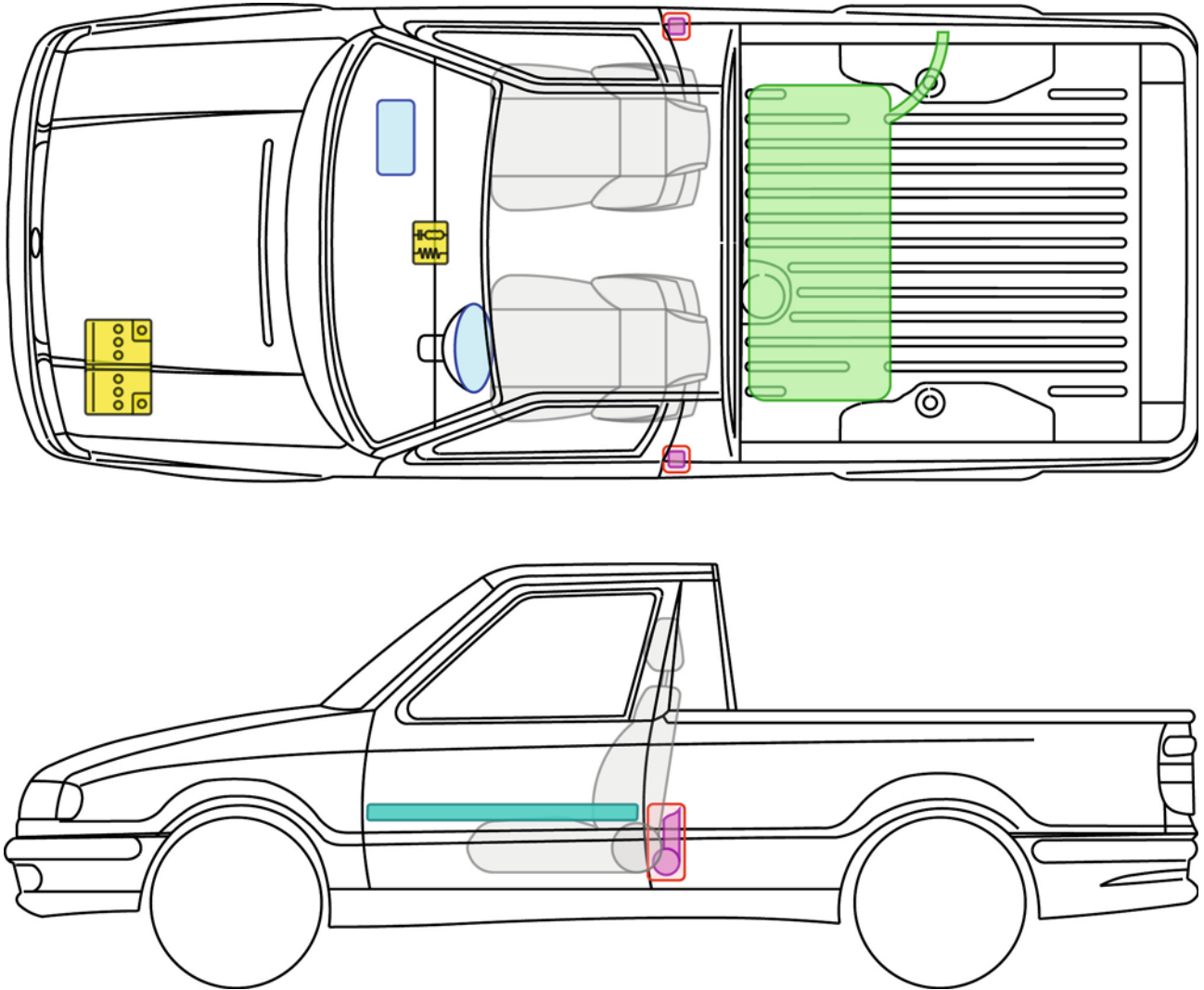

Caddy

(Pickup, 1997 - 2002)

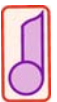

Legende

	Airbag		Karosserie-Verstärkung		Steuergerät	
					12 V-Batterie	
	Gurtstraffer				Kraftstofftank	







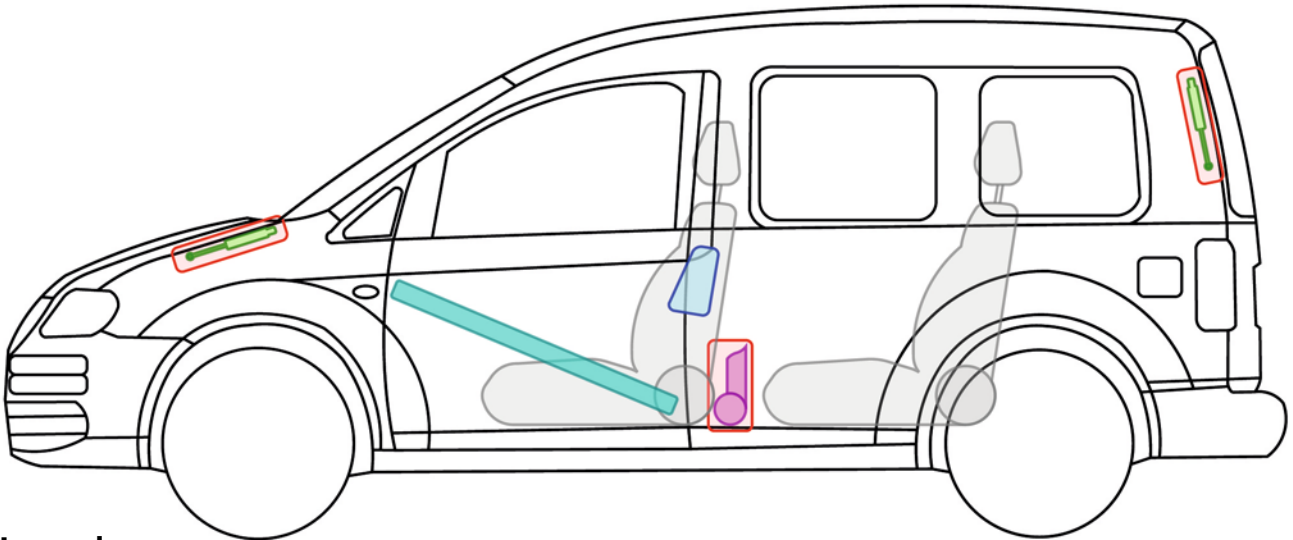
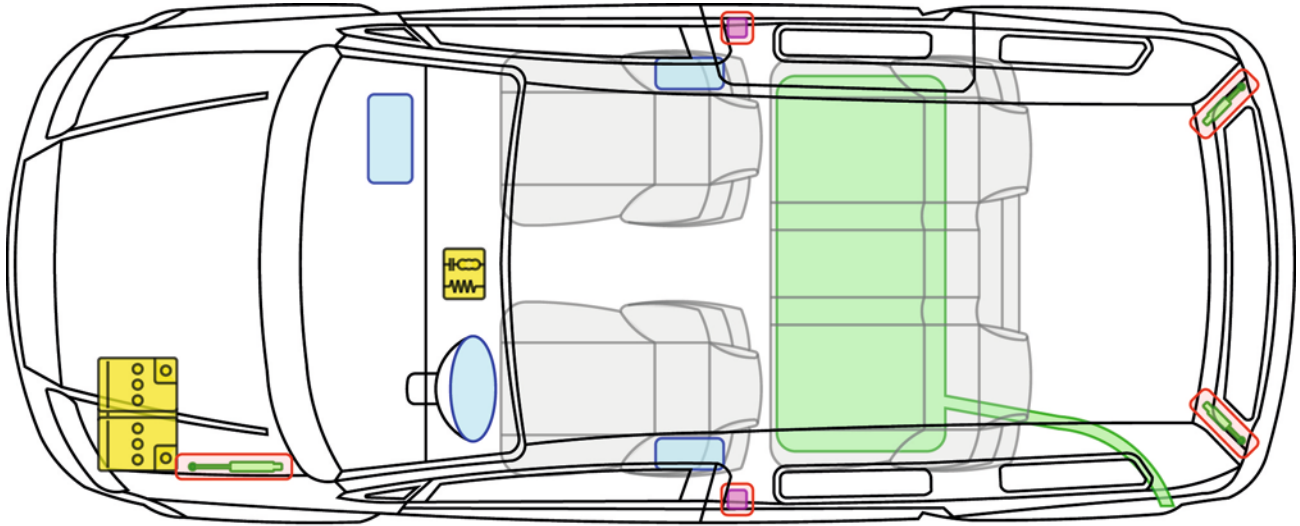

Caddy

(Kombi, ab 2004)

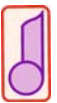

Legende

	Airbag		Karosserie-Verstärkung		Steuergerät	
					12 V-Batterie	
	Gurtstraffer		Gasdruck-dämpfer		Kraftstofftank	



Caddy

(Kombi EcoFuel, ab 2006)

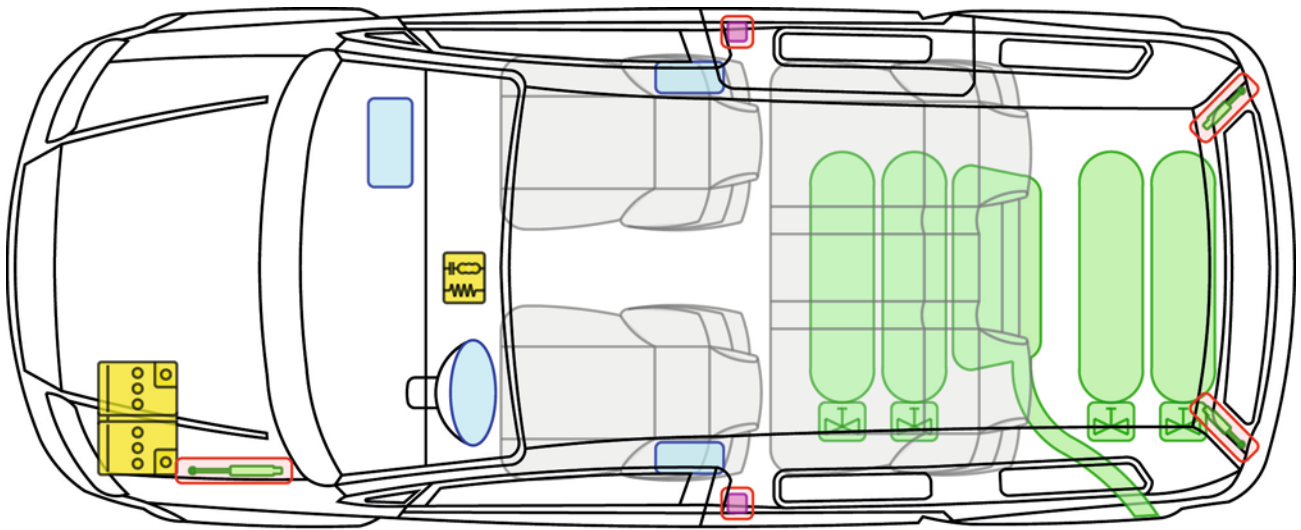





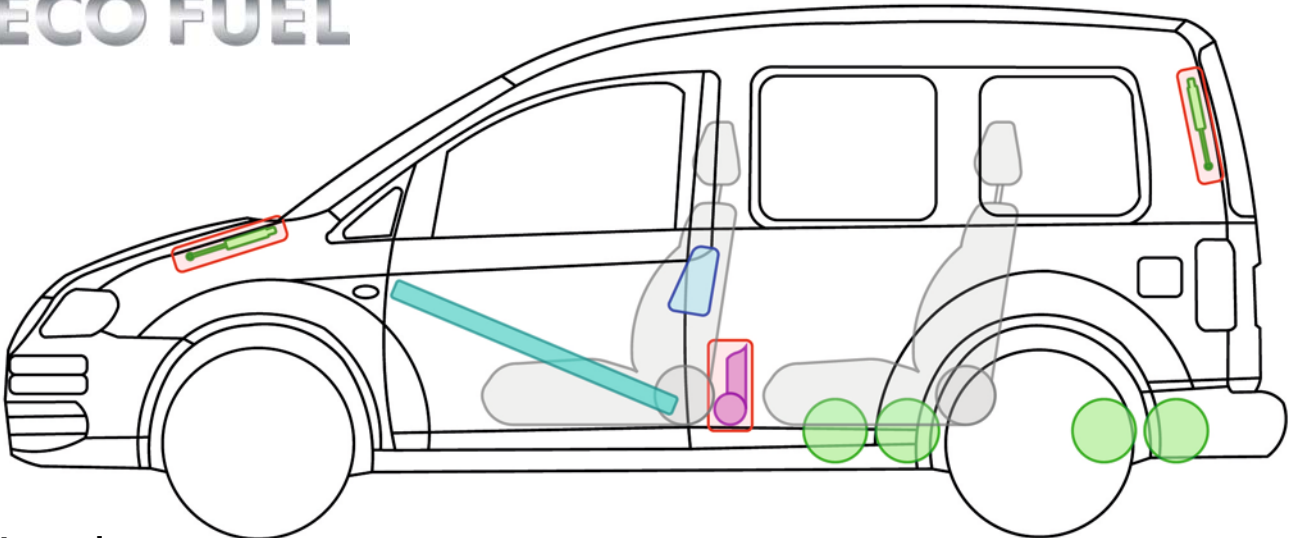

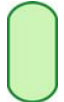

Erdgasantrieb

ECO FUEL



Legende

	Airbag		Karosserie-Verstärkung		Steuergerät		Gastank
					12 V-Batterie		Sicherheits-ventil
	Gurtstraffer		Gasdruck-dämpfer		Kraftstofftank		



Caddy (Kombi EcoFuel, ab 2006)



Caddy

(Kombi EcoFuel, ab 2006)



Hinweise zur Erdgasanlage

Gastanks manuell absperrn (bei Gasgeruch bzw. Austritt von Erdgas)

1. Zugang zu den Erdgastanks

- Der Zugang zu den Tanks erfolgt vom Unterboden aus.
- Die Gastanks sind durch eine Kunststoffabdeckung verkleidet. Um an die Erdgastanks zu gelangen, muss diese Abdeckung mit geeigneten Mitteln entfernt werden, ohne die darunter liegenden Bauteile der Gasanlage zu beschädigen.

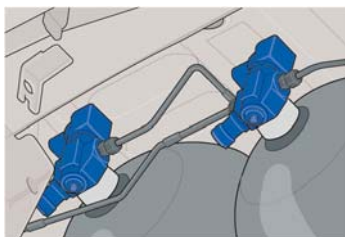

elektromagnetische Absperrventile an den Gastanks

2. Absperrhähne lokalisieren

- Jeder Gastank besitzt ein eigenes Flaschenventil mit einem manuellen Absperrhahn.
- Falls einsatzbedingt erforderlich muss jeder Gastank separat abgesperrt werden.



manueller Absperrhahn seitlich am Flaschenventil (bis 2008).

3. Gastank von Hand schließen

- Falls einsatzbedingt erforderlich muss jeder Gastank separat abgesperrt werden.
- Mit einem 5er-Maul- bzw. Ringschlüssel lässt sich das manuelle Absperrventil am Vierkant durch Drehen im Uhrzeigersinn bis zum Anschlag des Ventils verschließen.



manueller Absperrhahn am Fuß des Flaschenventils.



Caddy

(Bifuel, ab 2010)

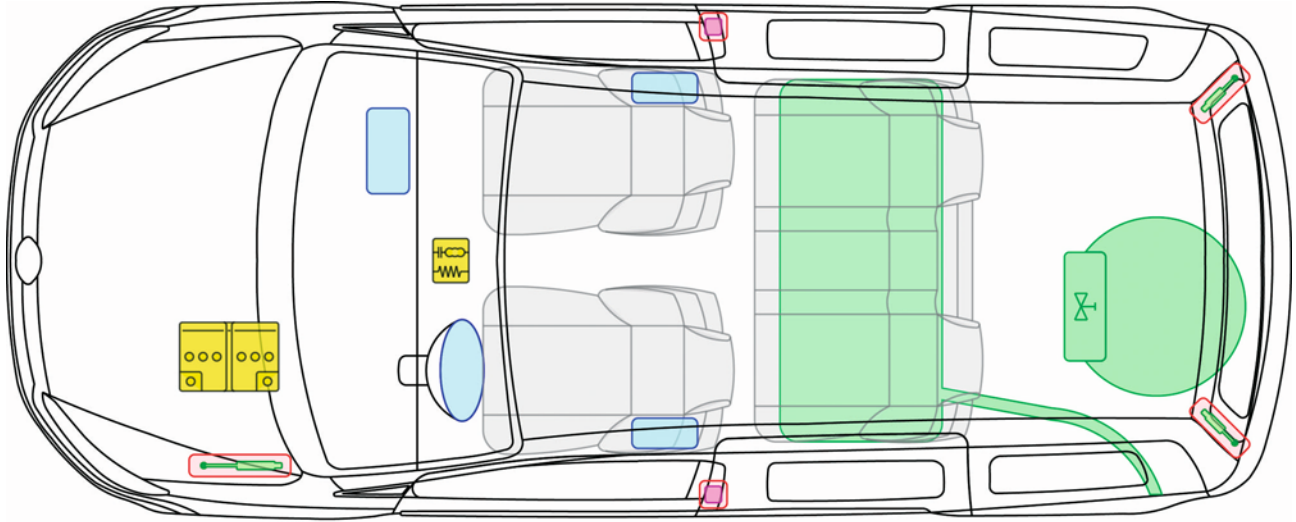





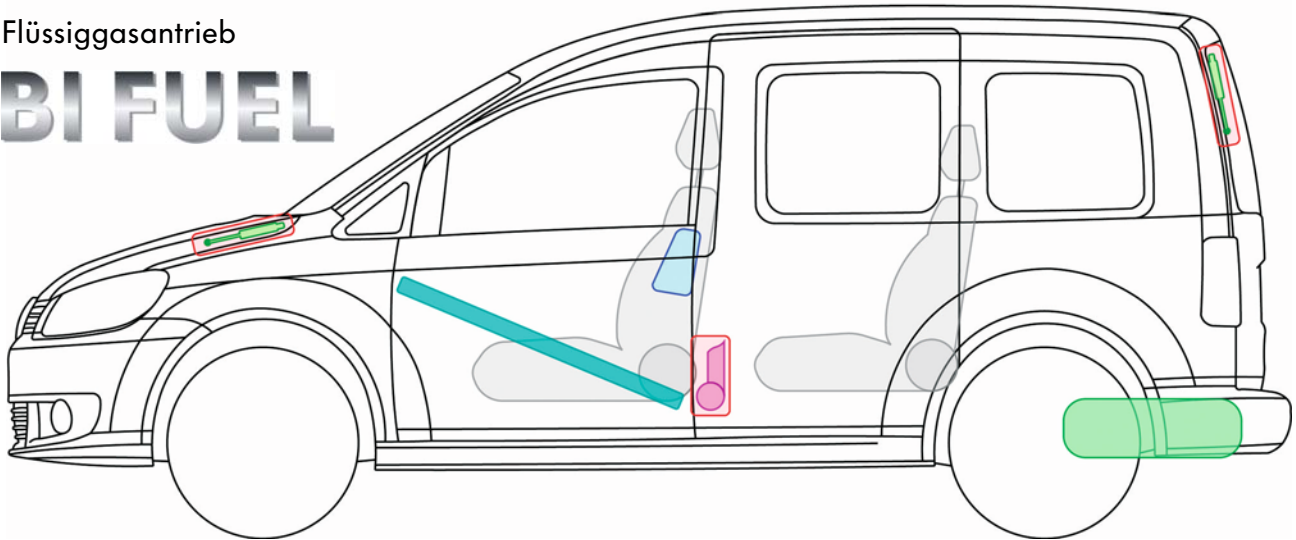

Flüssiggasantrieb

BI FUEL

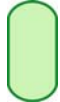

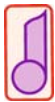
Legende

	Airbag		Karosserie-Verstärkung		Steuergerät		Gastank
					12V-Batterie		Sicherheits-ventil
	Gurtstraffer		Gasdruck-dämpfer		Kraftstofftank		



Caddy
(BiFuel, ab 2010)



Hinweise zur Flüssiggasanlage

Der Gastank der Flüssiggasanlage des Caddy BiFuel hat keine mechanische, manuelle Absperrmöglichkeit!



Der Flüssiggastank in der Reserveradmulde

1. Flüssiggastank lokalisieren

- Er ist unter dem Ladeboden in der Reserveradmulde montiert.
- Der Gastank verfügt nur über ein elektromagnetisches Absperrventil, das stromlos geschlossen ist.









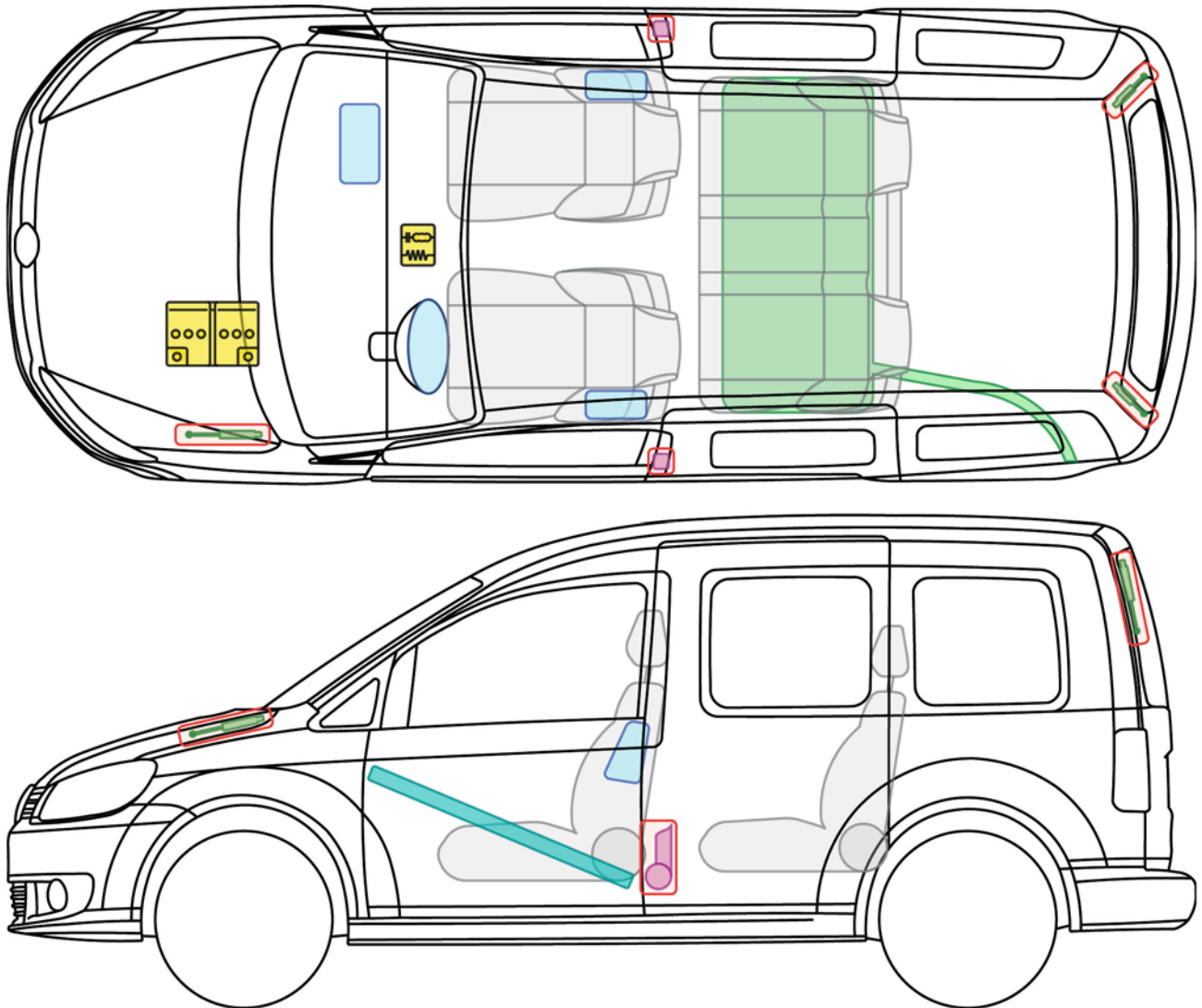

Caddy

(ab 2010)



Legende

	Airbag		Karosserie-Verstärkung		Steuergerät	
					12 V-Batterie	
	Gurtstraffer		Gasdruck-dämpfer		Kraftstofftank	



Caddy

(EcoFuel, ab 2010)

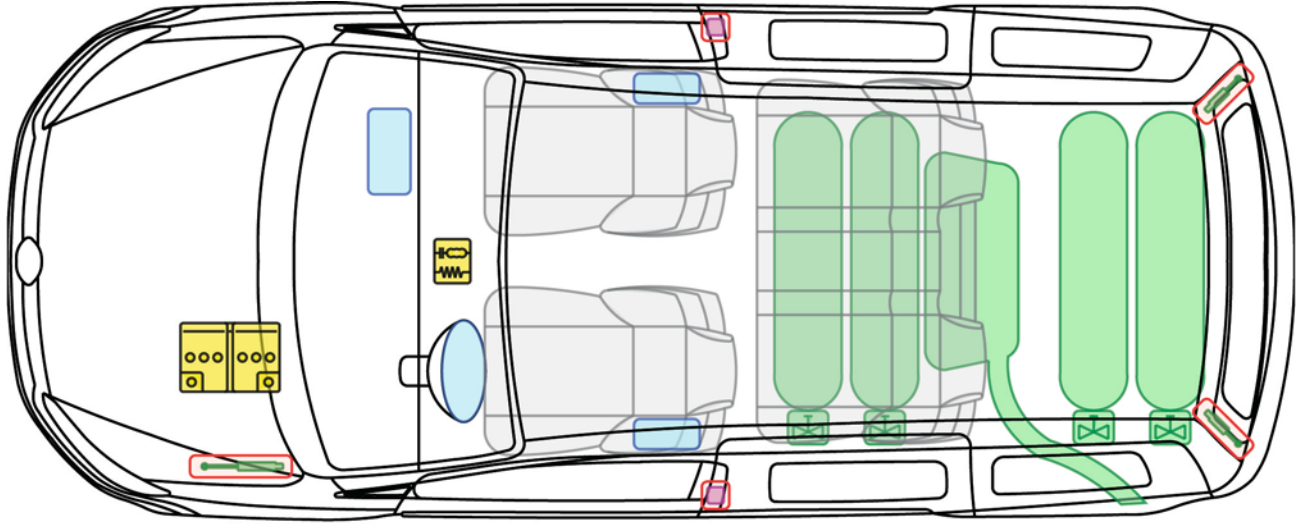





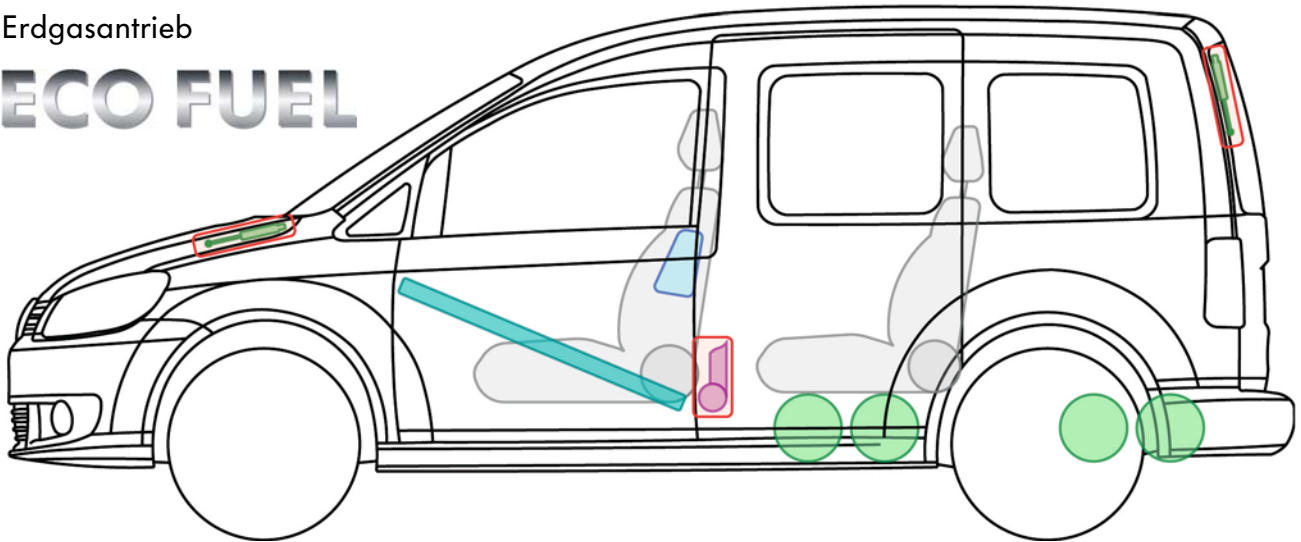



Erdgasantrieb

ECO FUEL

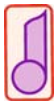

Legende

	Airbag		Karosserie-Verstärkung		Steuergerät		Gastank
					12 V-Batterie		Sicherheits-ventil
	Gurtstraffer		Gasdruck-dämpfer		Kraftstofftank		



Hinweise zur Erdgasanlage

Gastanks manuell absperren (bei Gasgeruch bzw. Austritt von Erdgas)

1. Zugang zu den Erdgastanks

- Der Zugang zu den Tanks erfolgt vom Unterboden aus.
- Die Gastanks sind durch eine Kunststoffabdeckung verkleidet. Um an die Erdgastanks zu gelangen, muss diese Abdeckung mit geeigneten Mitteln entfernt werden, ohne die darunter liegenden Bauteile der Gasanlage zu beschädigen.

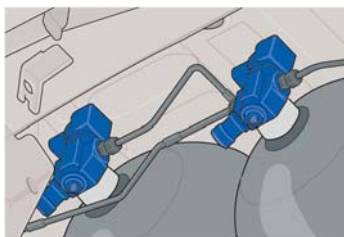

elektromagnetische Absperrventile an den Gastanks

2. Absperrhähne lokalisieren

- Jeder Gastank besitzt ein eigenes Flaschenventil mit einem manuellen Absperrhahn.
- Falls einsatzbedingt erforderlich muss jeder Gastank separat abgesperrt werden.



manueller Absperrhahn am Fuß des Flaschenventils.

3. Gastank von Hand schließen





- Falls einsatzbedingt erforderlich muss jeder Gastank separat abgesperrt werden.
- Mit einem 5er-Maul- bzw. Ringschlüssel lässt sich das manuelle Absperrventil am Vierkant durch Drehen im Uhrzeigersinn bis zum Anschlag des Ventils verschließen.

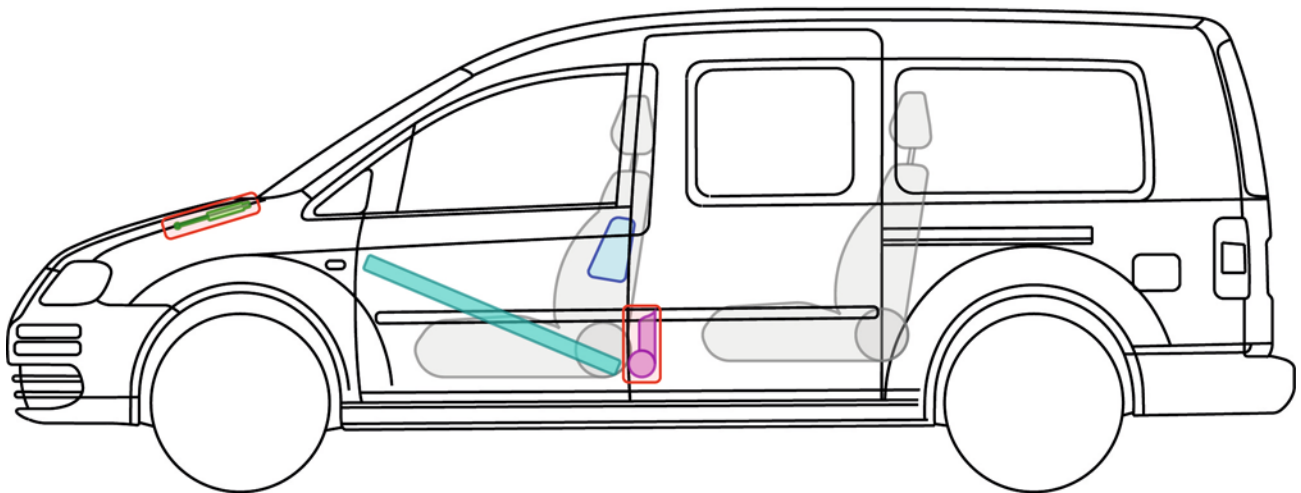
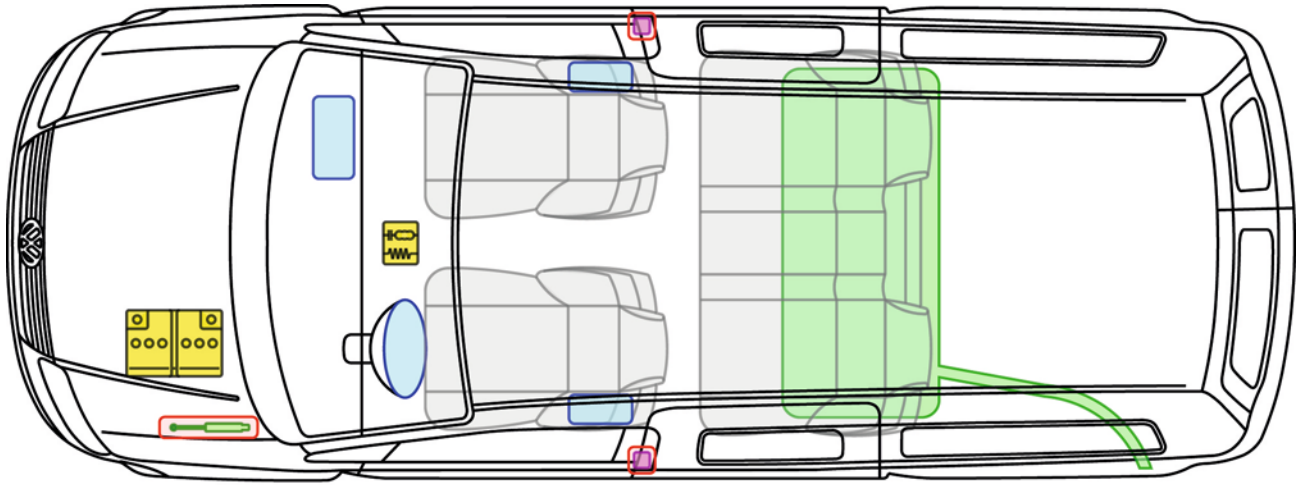

Caddy Maxi (2007 - 2010)

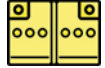
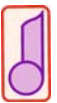

Legende

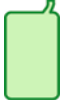
	Airbag		Karosserie-Verstärkung		Steuergerät
					12 V-Batterie
	Gurtstraffer		Gasdruck-dämpfer		Kraftstofftank



Caddy Maxi

(EcoFuel, 2007 - 2010)

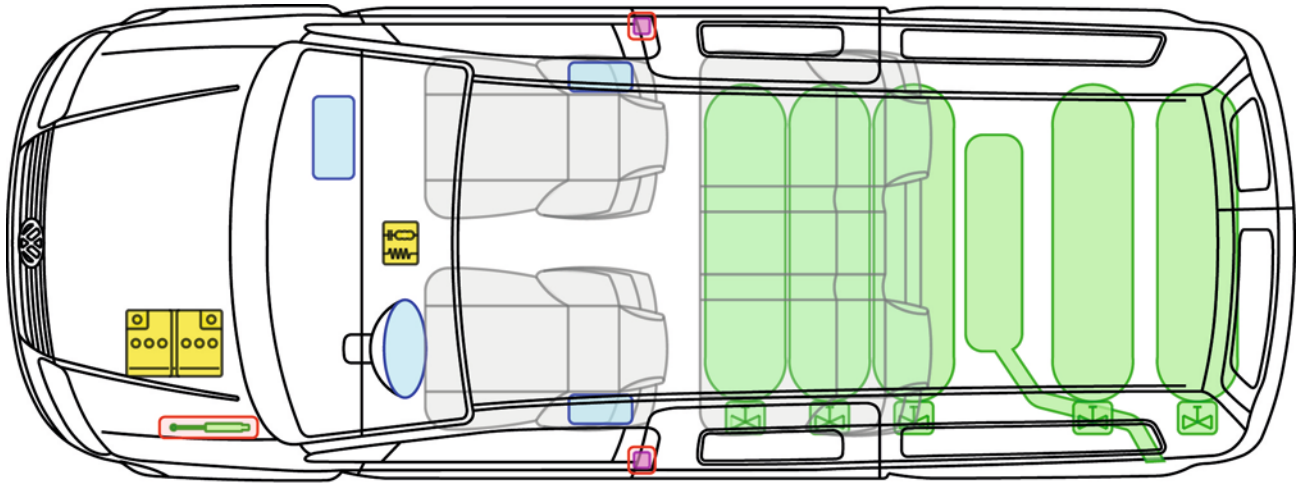





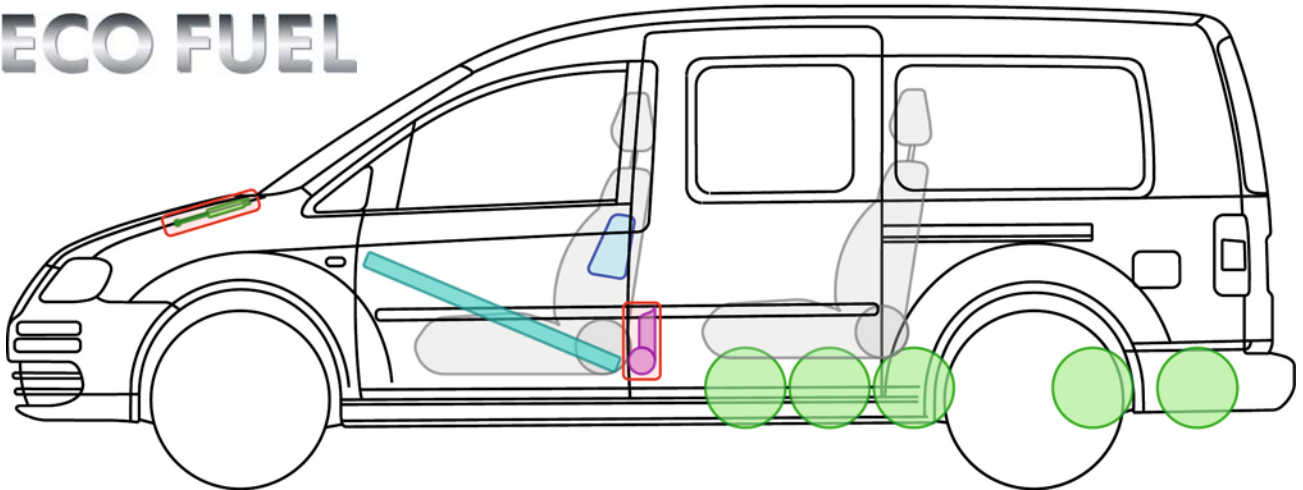



Erdgasantrieb

ECO FUEL

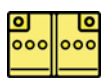

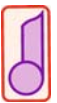
Legende

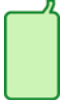
	Airbag		Karosserie-Verstärkung		Steuergerät		Gastank
					12 V-Batterie		Sicherheits-ventil
	Gurtstraffer		Gasdruck-dämpfer		Kraftstofftank		



Hinweise zur Erdgasanlage

Gastanks manuell absperren (bei Gasgeruch bzw. Austritt von Erdgas)

1. Zugang zu den Erdgastanks

- Der Zugang zu den Tanks erfolgt vom Unterboden aus.
- Die Gastanks sind durch eine Kunststoffabdeckung verkleidet. Um an die Erdgastanks zu gelangen, muss diese Abdeckung mit geeigneten Mitteln entfernt werden, ohne die darunter liegenden Bauteile der Gasanlage zu beschädigen.

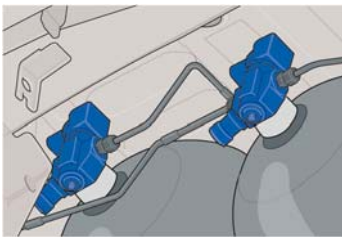

elektromagnetische Absperrventile an den Gastanks

2. Absperrhähne lokalisieren

- Jeder Gastank besitzt ein eigenes Flaschenventil mit einem manuellen Absperrhahn.
- Falls einsatzbedingt erforderlich muss jeder Gastank separat abgesperrt werden.

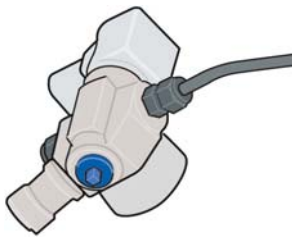

manueller Absperrhahn am Fuß des Flaschenventils.

3. Gastank von Hand schließen

- Falls einsatzbedingt erforderlich muss jeder Gastank separat abgesperrt werden.
- Mit einem 5er-Maul- bzw. Ringschlüssel lässt sich das manuelle Absperrventil am Vierkant durch Drehen im Uhrzeigersinn bis zum Anschlag des Ventils verschließen.







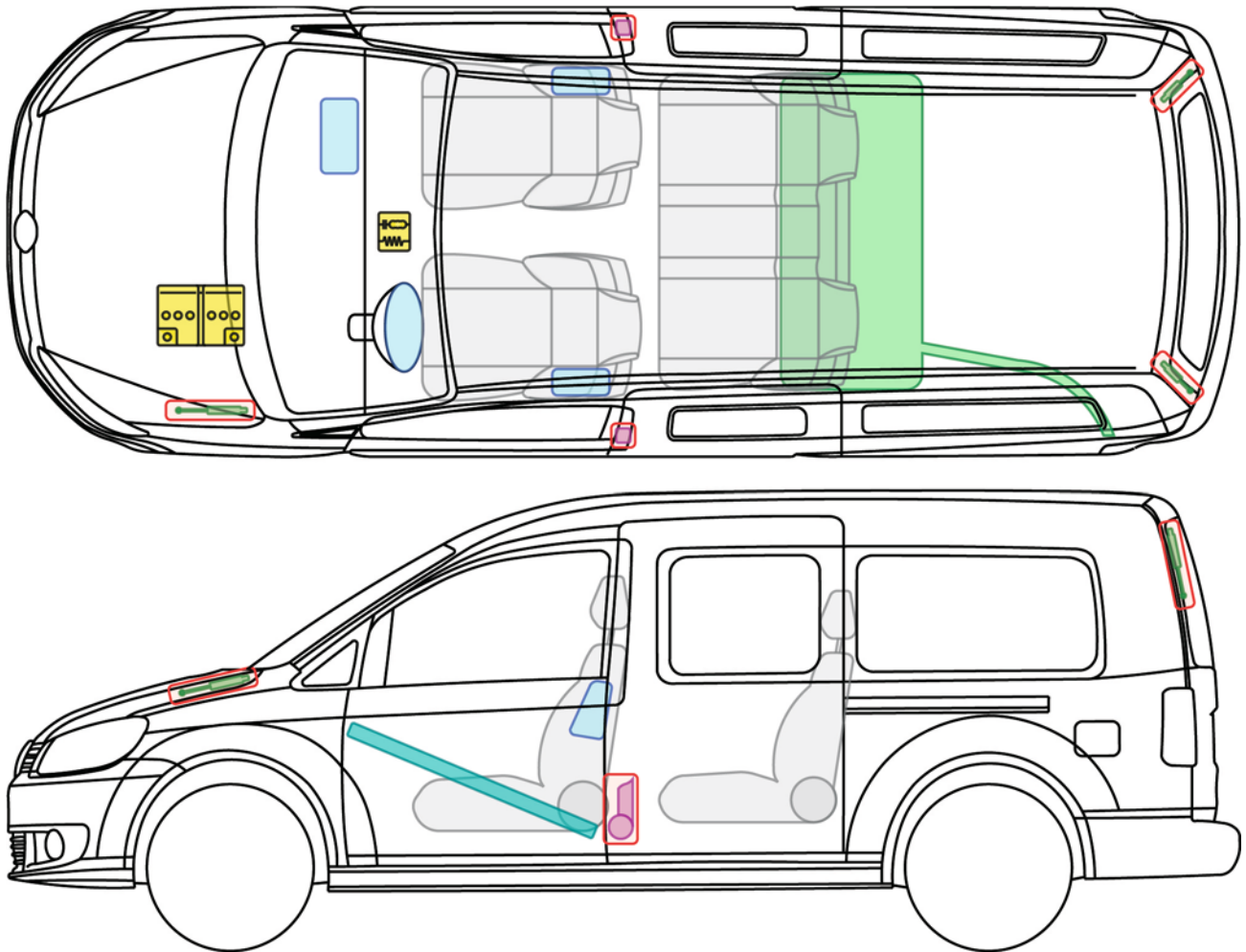

Caddy Maxi

(ab 2010)

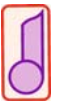

Legende

	Airbag		Karosserie-Verstärkung		Steuergerät	
					12 V-Batterie	
	Gurtstraffer		Gasdruck-dämpfer		Kraftstofftank	



Caddy Maxi

(EcoFuel, ab 2010)

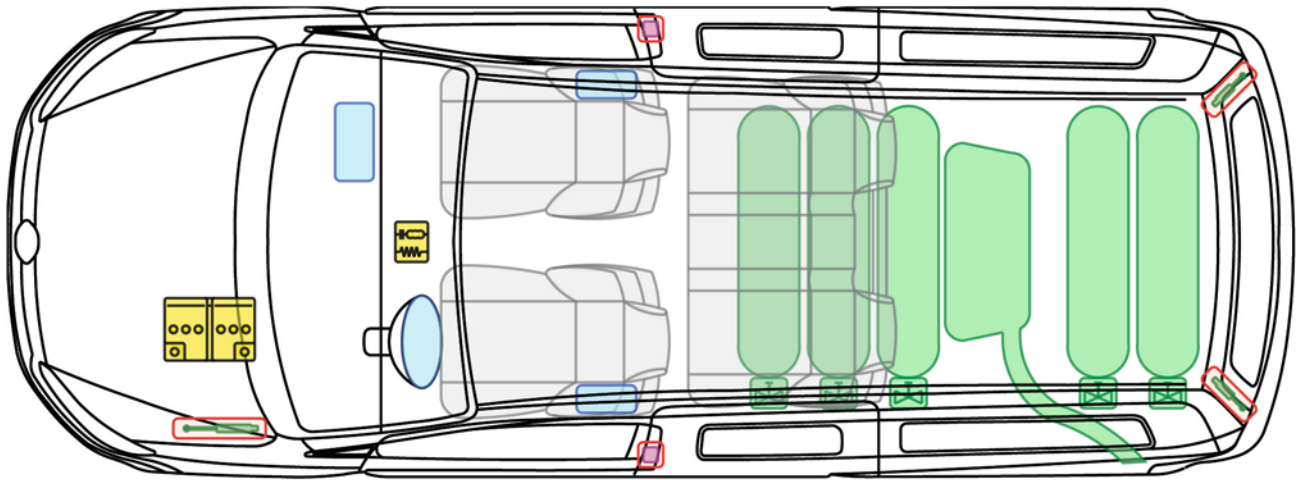





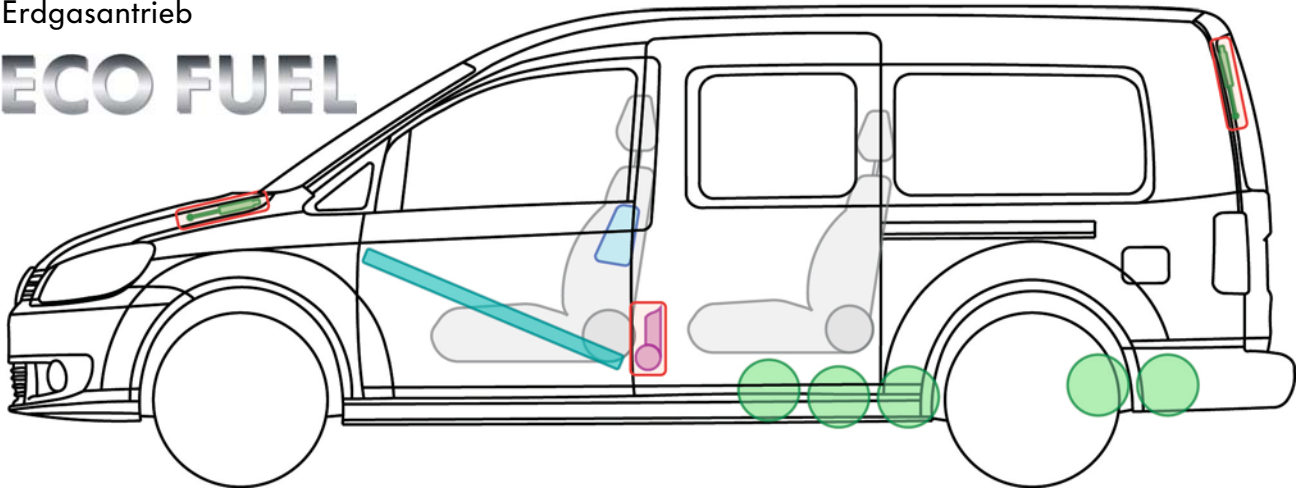



Erdgasantrieb

ECO FUEL

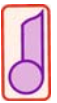

Legende

	Airbag		Karosserie-Verstärkung		Steuergerät		Gastank
					12 V-Batterie		Sicherheits-ventil
	Gurtstraffer		Gasdruck-dämpfer		Kraftstofftank		



Hinweise zur Erdgasanlage

Gastanks manuell absperren (bei Gasgeruch bzw. Austritt von Erdgas)

1. Zugang zu den Erdgastanks

- Der Zugang zu den Tanks erfolgt vom Unterboden aus.
- Die Gastanks sind durch eine Kunststoffabdeckung verkleidet. Um an die Erdgastanks zu gelangen, muss diese Abdeckung mit geeigneten Mitteln entfernt werden, ohne die darunter liegenden Bauteile der Gasanlage zu beschädigen.

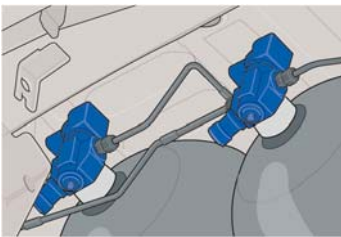

elektromagnetische Absperrventile an den Gastanks

2. Absperrhähne lokalisieren

- Jeder Gastank besitzt ein eigenes Flaschenventil mit einem manuellen Absperrhahn.
- Falls einsatzbedingt erforderlich muss jeder Gastank separat abgesperrt werden.

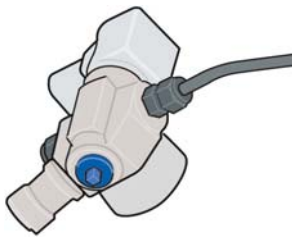

manueller Absperrhahn am Fuß des Flaschenventils.

3. Gastank von Hand schließen

- Falls einsatzbedingt erforderlich muss jeder Gastank separat abgesperrt werden.
- Mit einem 5er-Maul- bzw. Ringschlüssel lässt sich das manuelle Absperrventil am Vierkant durch Drehen im Uhrzeigersinn bis zum Anschlag des Ventils verschließen.



Caddy Maxi

(Bifuel, ab 2010)

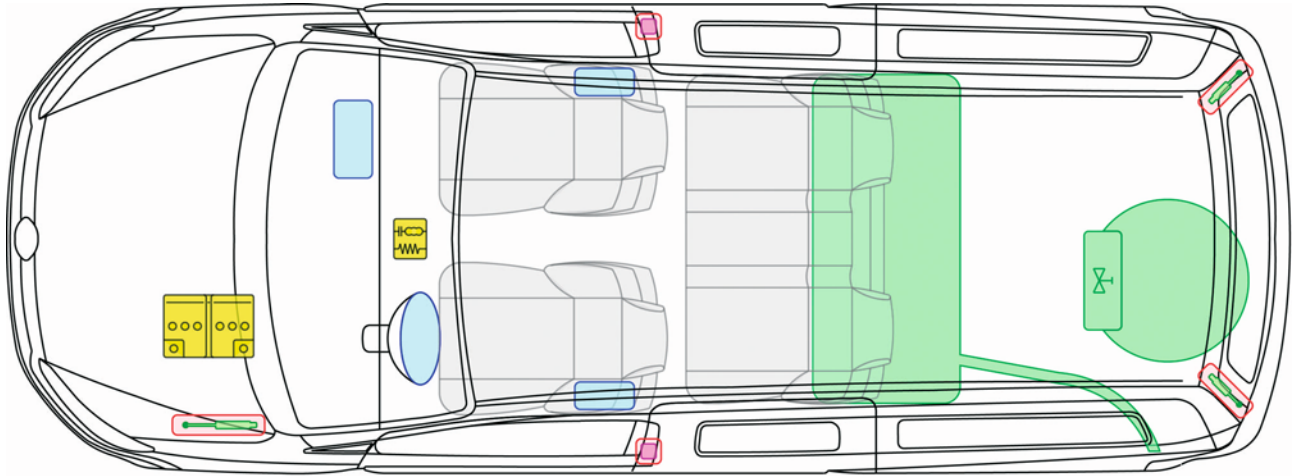





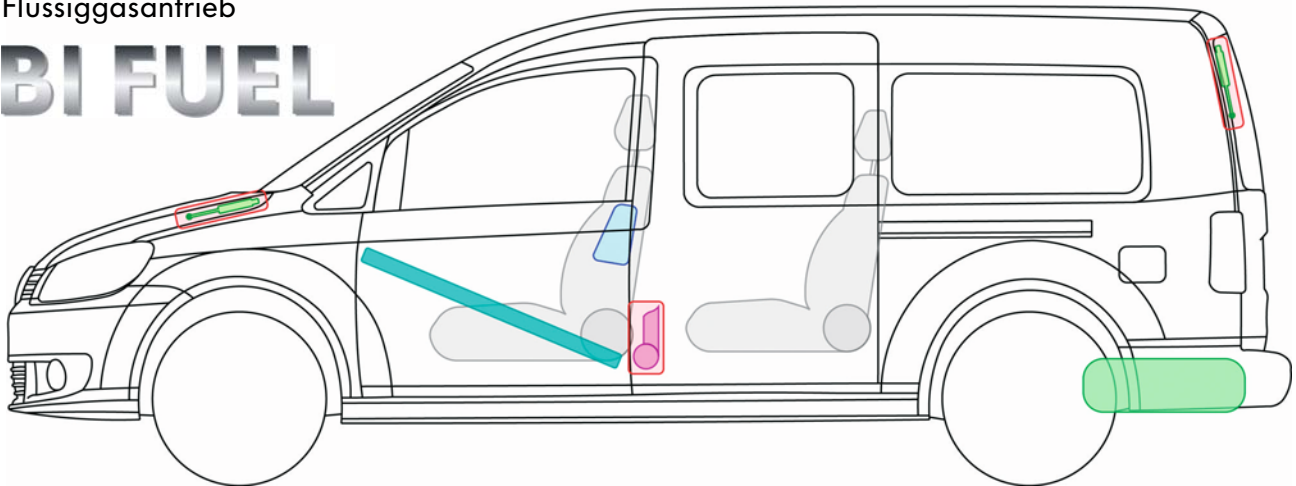



Flüssiggasantrieb

BI FUEL

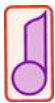

Legende

	Airbag		Karosserie-Verstärkung		Steuergerät		Gastank
					12V-Batterie		Sicherheits-ventil
	Gurtstraffer		Gasdruck-dämpfer		Kraftstofftank		



Caddy Maxi (BiFuel, ab 2010)



Hinweise zur Flüssiggasanlage

Der Gastank der Flüssiggasanlage des Caddy Maxi BiFuel hat keine mechanische, manuelle Abspermmöglichkeit!



Der Flüssiggastank in der Reserveradmulde

1. Flüssiggastank lokalisieren

- Er ist unter dem Ladeboden in der Reserveradmulde montiert.
- Der Gastank verfügt nur über ein elektromagnetisches Absperrventil, das stromlos geschlossen ist.









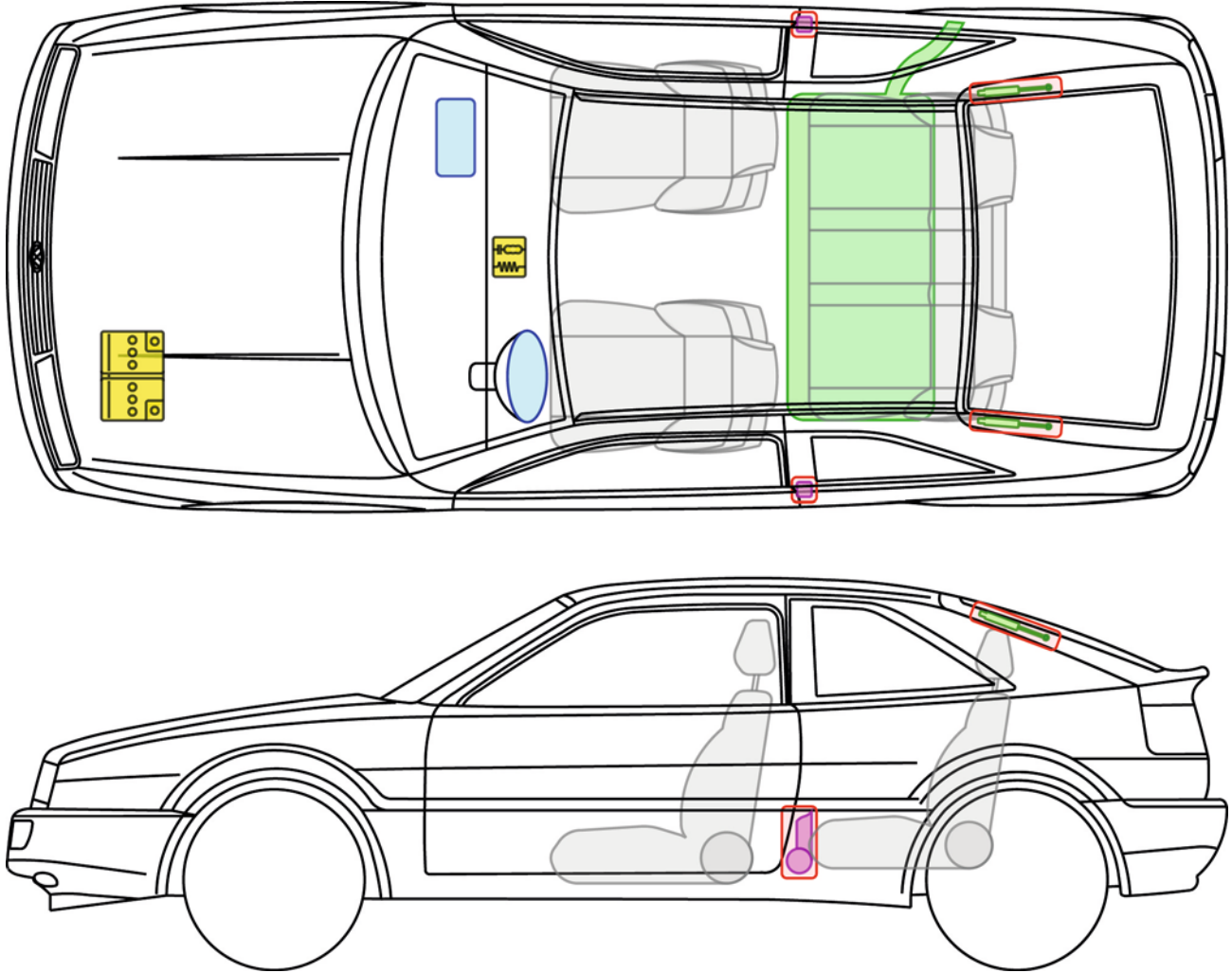

Corrado

(1988 - 1995)

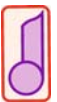

Legende

	Airbag		Karosserie-Verstärkung		Steuergerät
					12 V-Batterie
	Gurtstraffer		Gasdruck-dämpfer		Kraftstofftank



Crafter



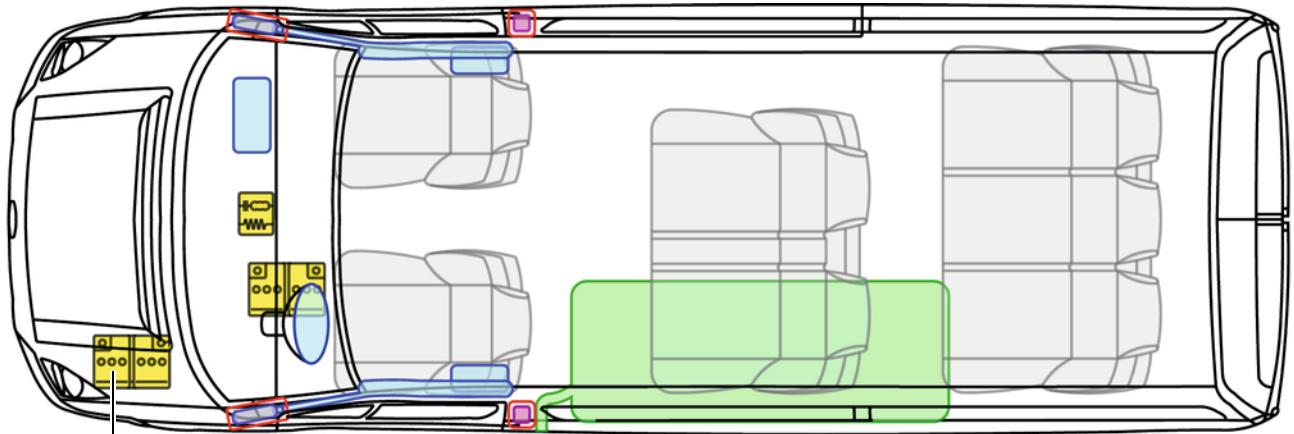



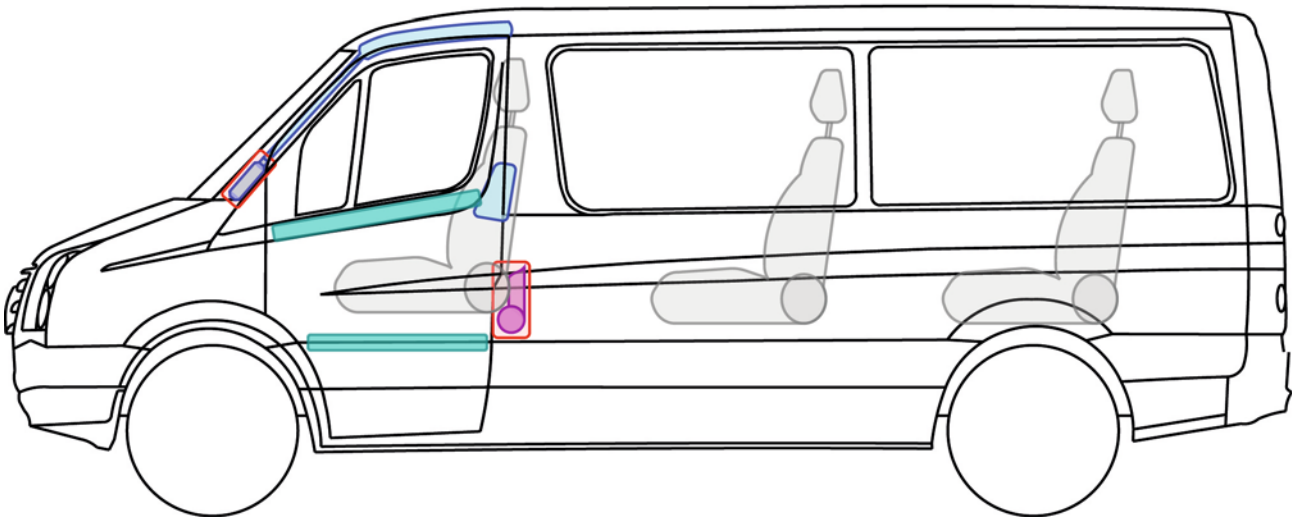

(ab 2006)



ausstattungsabhängig 2. Batterie im Motorraum



Legende

	Airbag		Karosserie-Verstärkung		Steuergerät
	Gas-generator				12V-Batterie
	Gurtstraffer		Gasdruck-dämpfer		Kraftstofftank



Fahrzeug deaktivieren

Batterie abklemmen

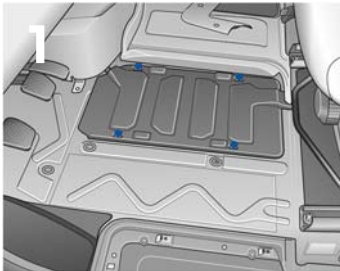

1. Batterieabdeckung im Fußraum vor dem Fahrersitz lokalisieren

- Bodenbelag entfernen.
- 4 Verschraubungen lösen und Abdeckung abnehmen

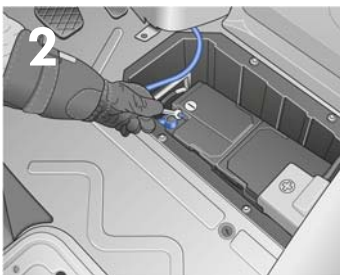

2. Masseanschluss (-) an der Batterie abklemmen



Optionale Methode: Masseanschlusstecker (Sonderausstattung) entriegeln

- Masseanschlusstecker an der Spritzwand neben dem Gaspedal lokalisieren
- Stecker mit geeignetem Werkzeug entriegeln und abziehen



Crafter Fahrgestell



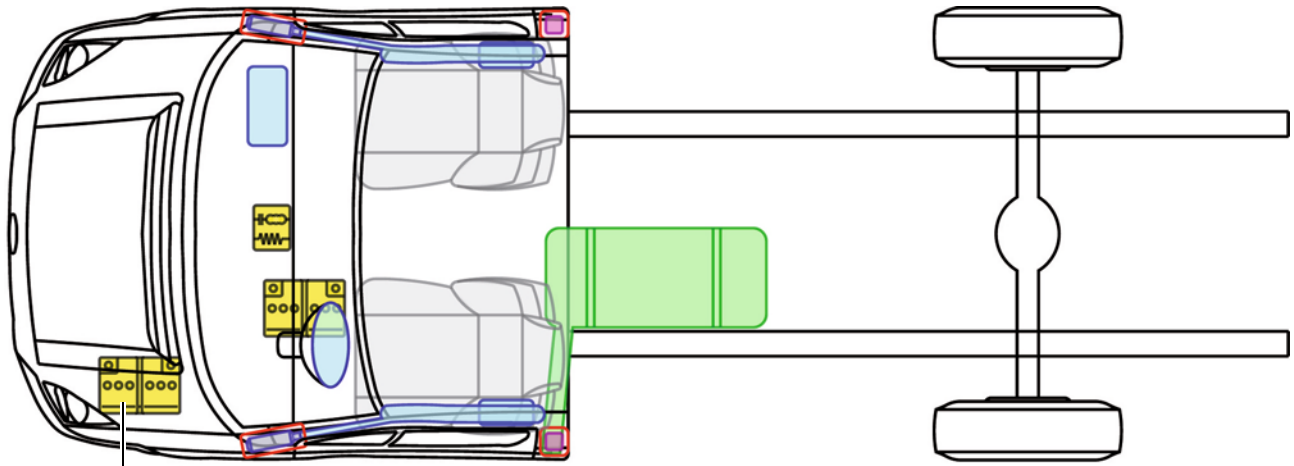

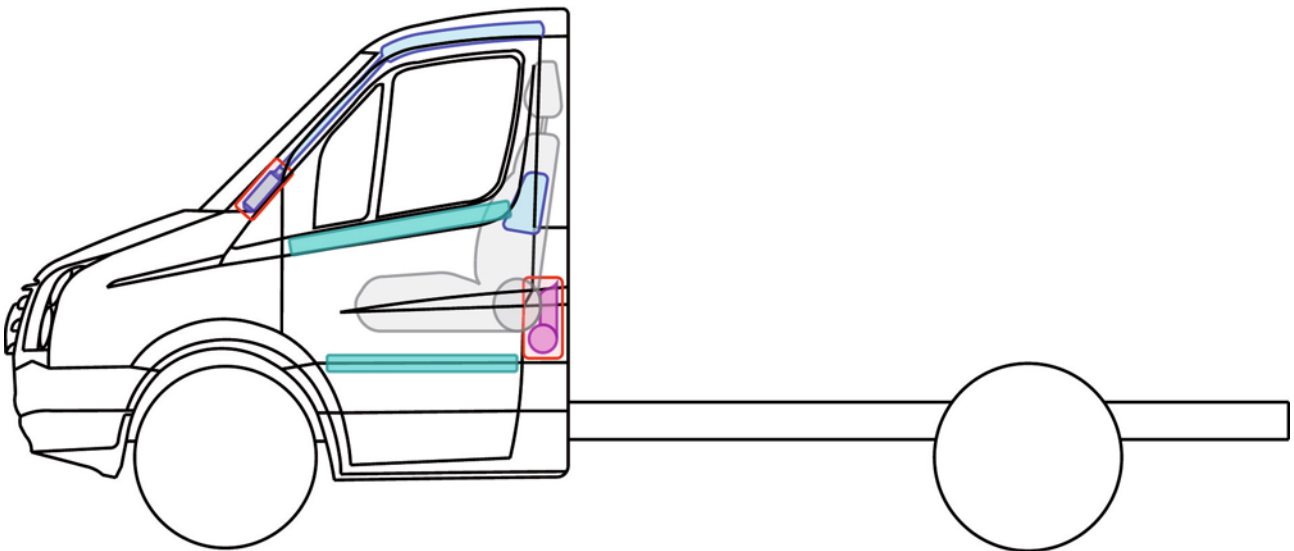

(2-Türer, ab 2006)



ausstattungsabhängig 2. Batterie im Motorraum



Legende

	Airbag		Karosserie-Verstärkung		Steuergerät	
	Gas-generator				12V-Batterie	
	Gurtstraffer				Kraftstofftank	



Fahrzeug deaktivieren

Batterie abklemmen

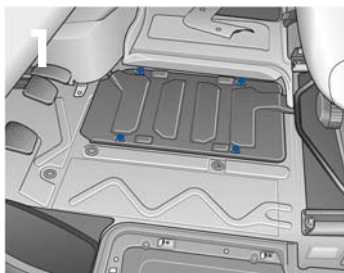

1. Batterieabdeckung im Fußraum vor dem Fahrersitz lokalisieren

- Bodenbelag entfernen.
- 4 Verschraubungen lösen und Abdeckung abnehmen

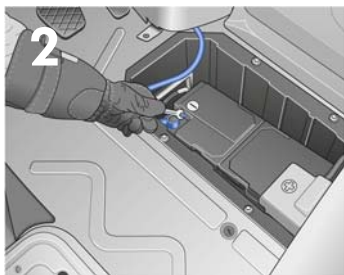

2. Masseanschluss (-) an der Batterie abklemmen



Masseanschlusstecker (Sonderausstattung) entriegeln

- Masseanschlusstecker an der Spritzwand neben dem Gaspedal lokalisieren
- Stecker mit geeignetem Werkzeug entriegeln und abziehen



Crafter Fahrgestell

(4-Türer, ab 2006)

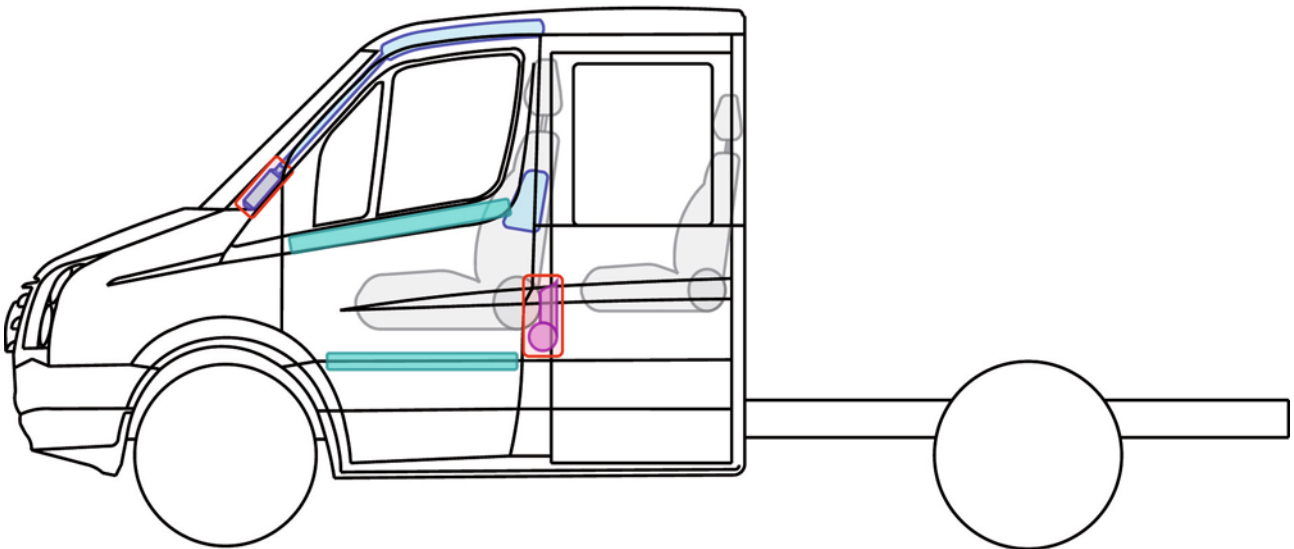
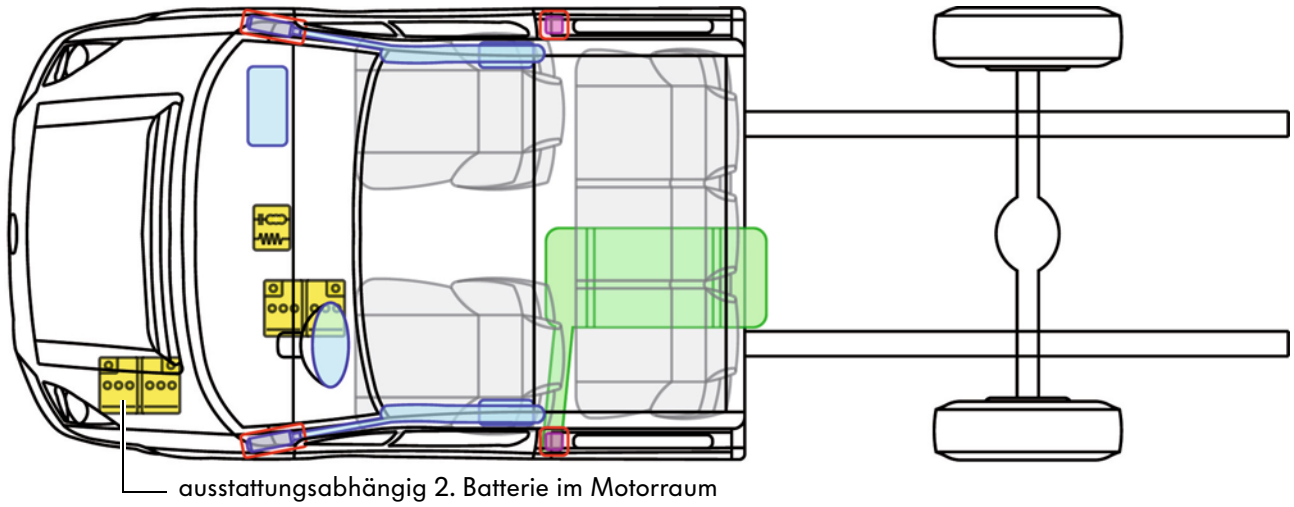

Legende

	Airbag		Karosserie-Verstärkung		Steuergerät	
	Gas-generator				12V-Batterie	
	Gurtstraffer				Kraftstofftank	



Crafter Fahrgestell

(4-Türer, ab 2006)



Fahrzeug deaktivieren

Batterie abklemmen

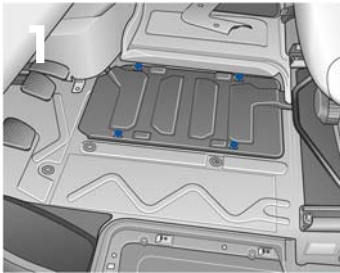

1. Batterieabdeckung im Fußraum vor dem Fahrersitz lokalisieren

- Bodenbelag entfernen.
- 4 Verschraubungen lösen und Abdeckung abnehmen

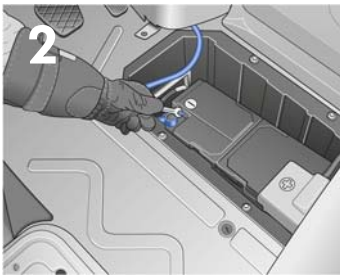

2. Masseanschluss (-) an der Batterie abklemmen



Masseanschlusstecker (Sonderausstattung) entriegeln

- Masseanschlusstecker an der Spritzwand neben dem Gaspedal lokalisieren
- Stecker mit geeignetem Werkzeug entriegeln und abziehen



Eos



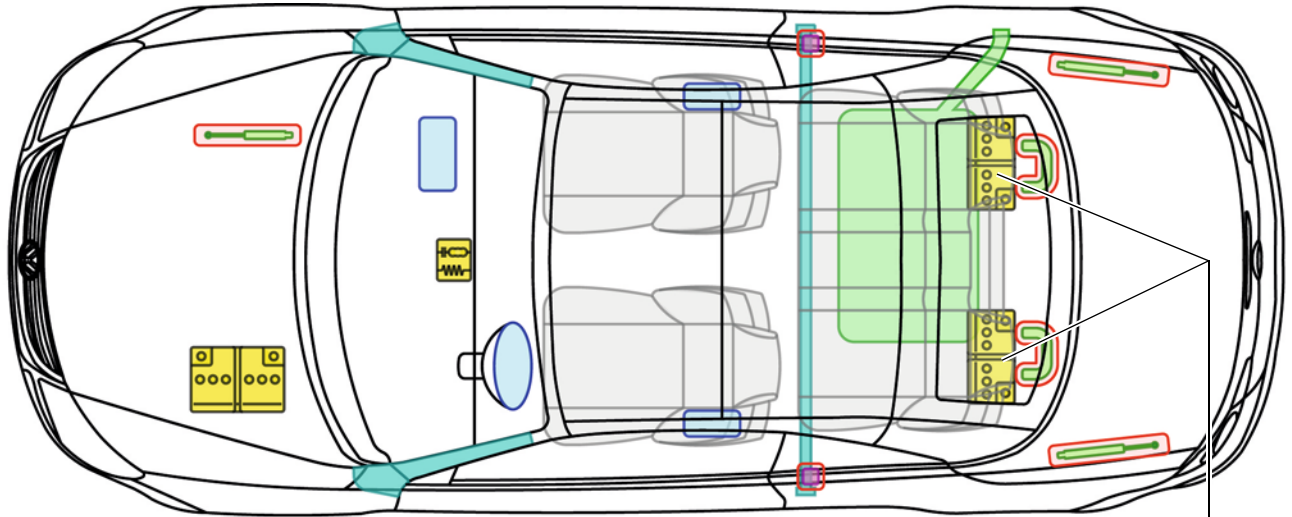

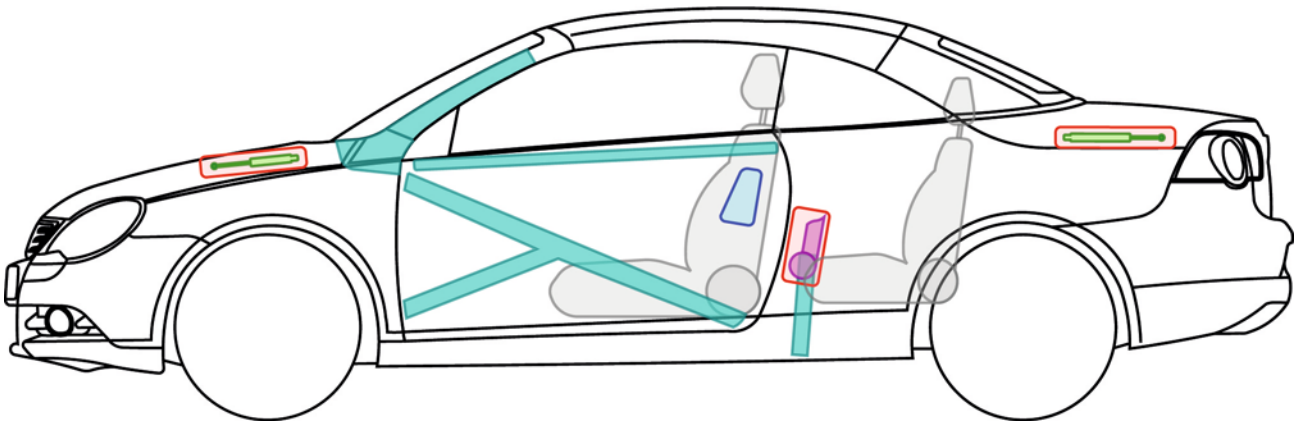

(ab 2006)



2 Batterien hinten nur bei VR6-Motor

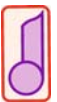

Legende

	Airbag		Karosserie-Verstärkung		Steuergerät
			Überrollschutz		12V-Batterie
	Gurtstraffer		Gasdruckdämpfer		Kraftstofftank



Eos
(ab 2006)



Fahrzeug deaktivieren

Batterien abklemmen (nur bei Eos mit VR6-Motor)

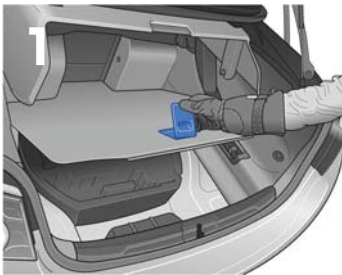

1. Kofferraumboden entriegeln und hochklappen

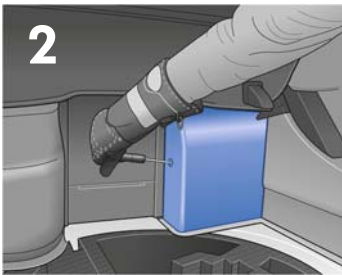

2. Batterieabdeckungen lösen und abnehmen

- Abdeckung rechts hinter der Rücksitzlehne abnehmen
- Abdeckung links hinter der Rücksitzlehne abnehmen

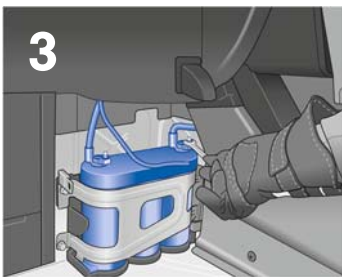

3. Beide Batterien abklemmen

- Masseanschluss an der Batterie auf der rechten Fahrzeugseite lösen und abziehen.
- Masseanschluss an der zweiten Batterie auf der linken Fahrzeugseite lösen und abziehen.

E

Eos (ab 2006)







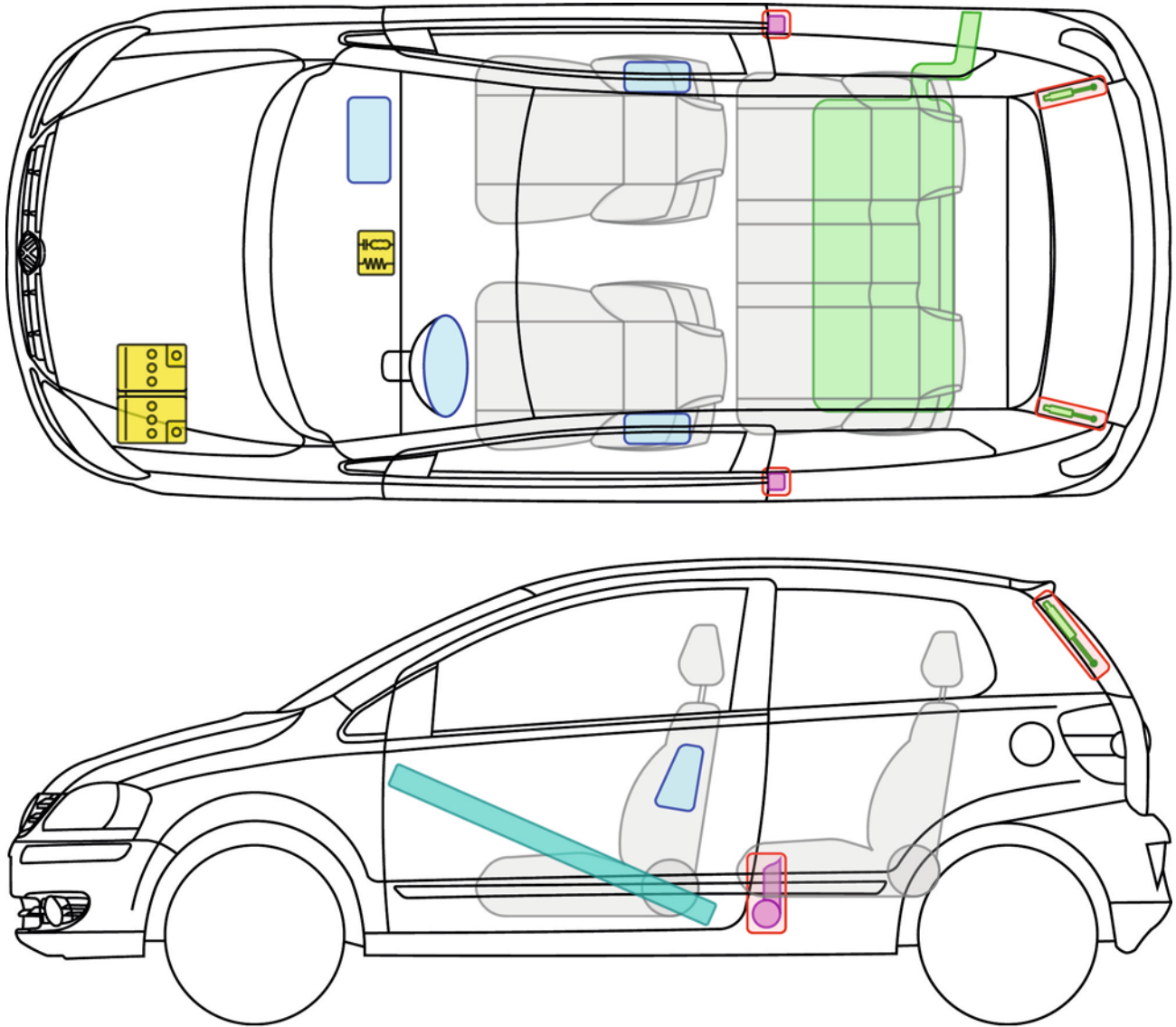

Fox

(ab 2005)

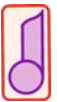

Legende

	Airbag		Karosserie-Verstärkung		Steuergerät
					12V-Batterie
	Gurtstraffer		Gasdruck-dämpfer		Kraftstofftank







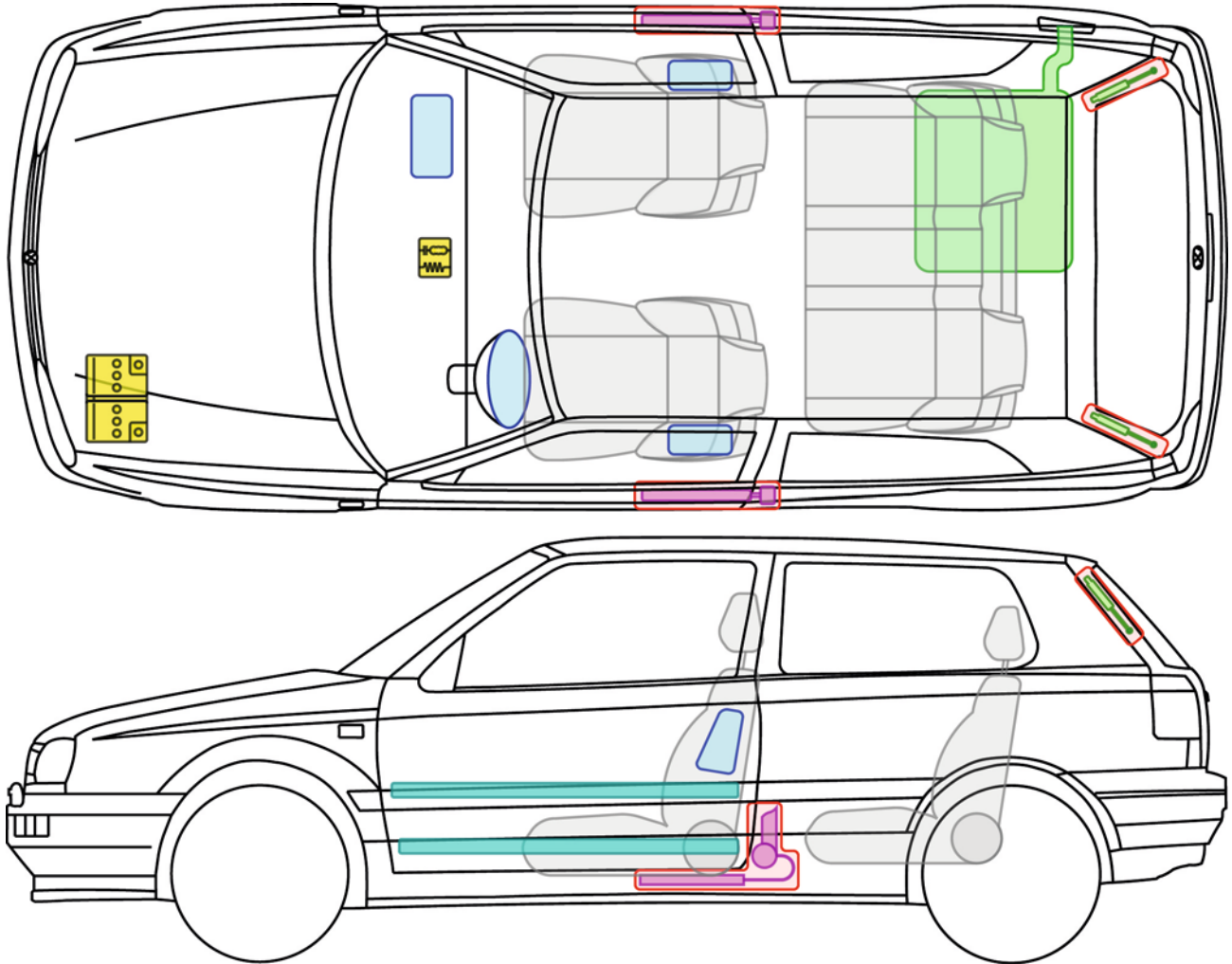

Golf 3

(3-Türer, 1991 - 1997)



Legende

	Airbag		Karosserie-Verstärkung		Steuergerät
					12 V-Batterie
	Gurtstraffer		Gasdruck-dämpfer		Kraftstofftank



Golf 3 (3-Türer, 1991 - 1997)







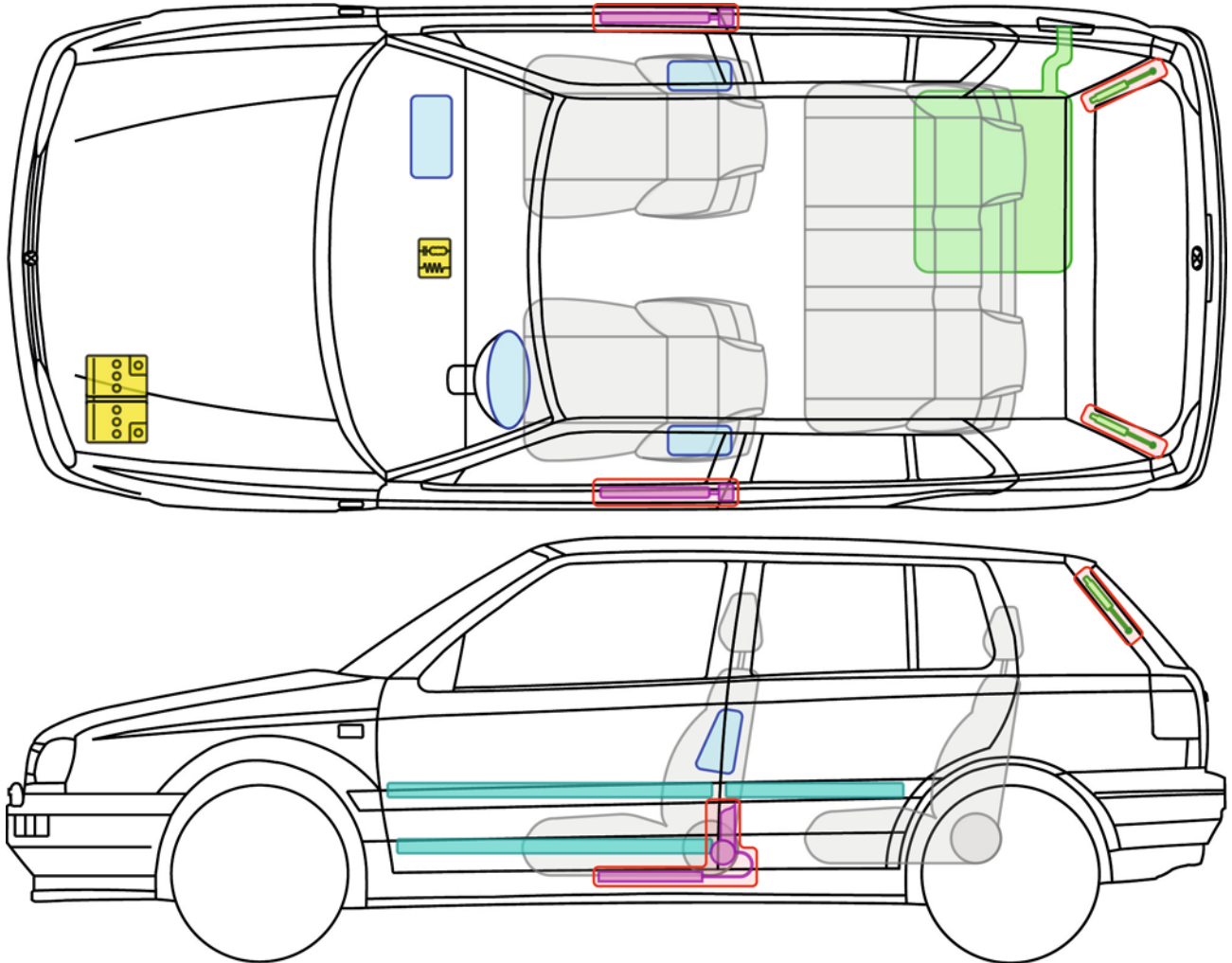

Golf 3

(5-Türer, 1991 - 1997)



Legende

	Airbag		Karosserie-Verstärkung		Steuergerät	
					12 V-Batterie	
	Gurtstraffer		Gasdruck-dämpfer		Kraftstofftank	







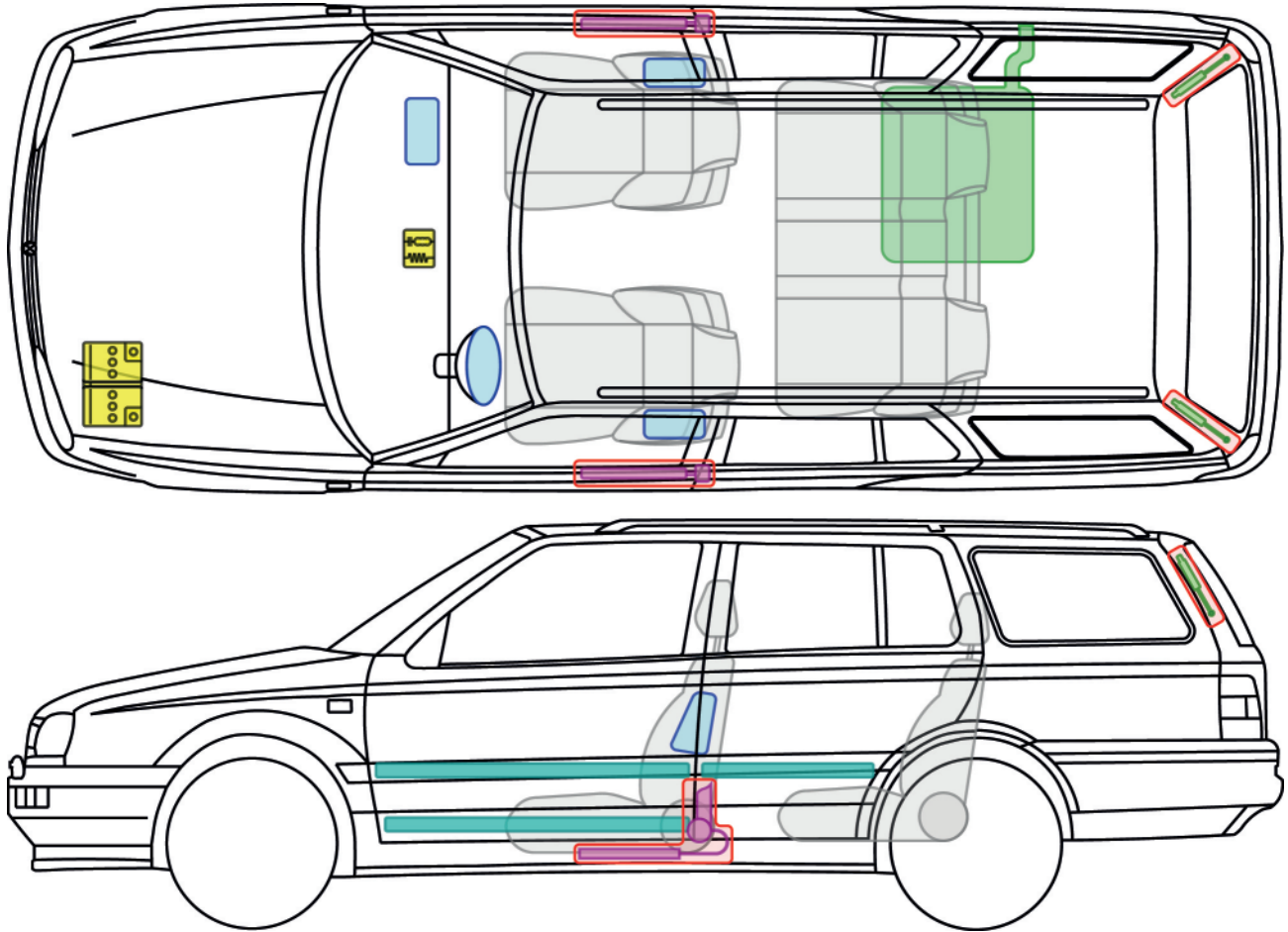

Golf 3

(Variant, 1993 - 1999)



Legende

	Airbag		Karosserie-Verstärkung		Steuergerät
					12 V-Batterie
	Gurtstraffer		Gasdruckdämpfer		Kraftstofftank







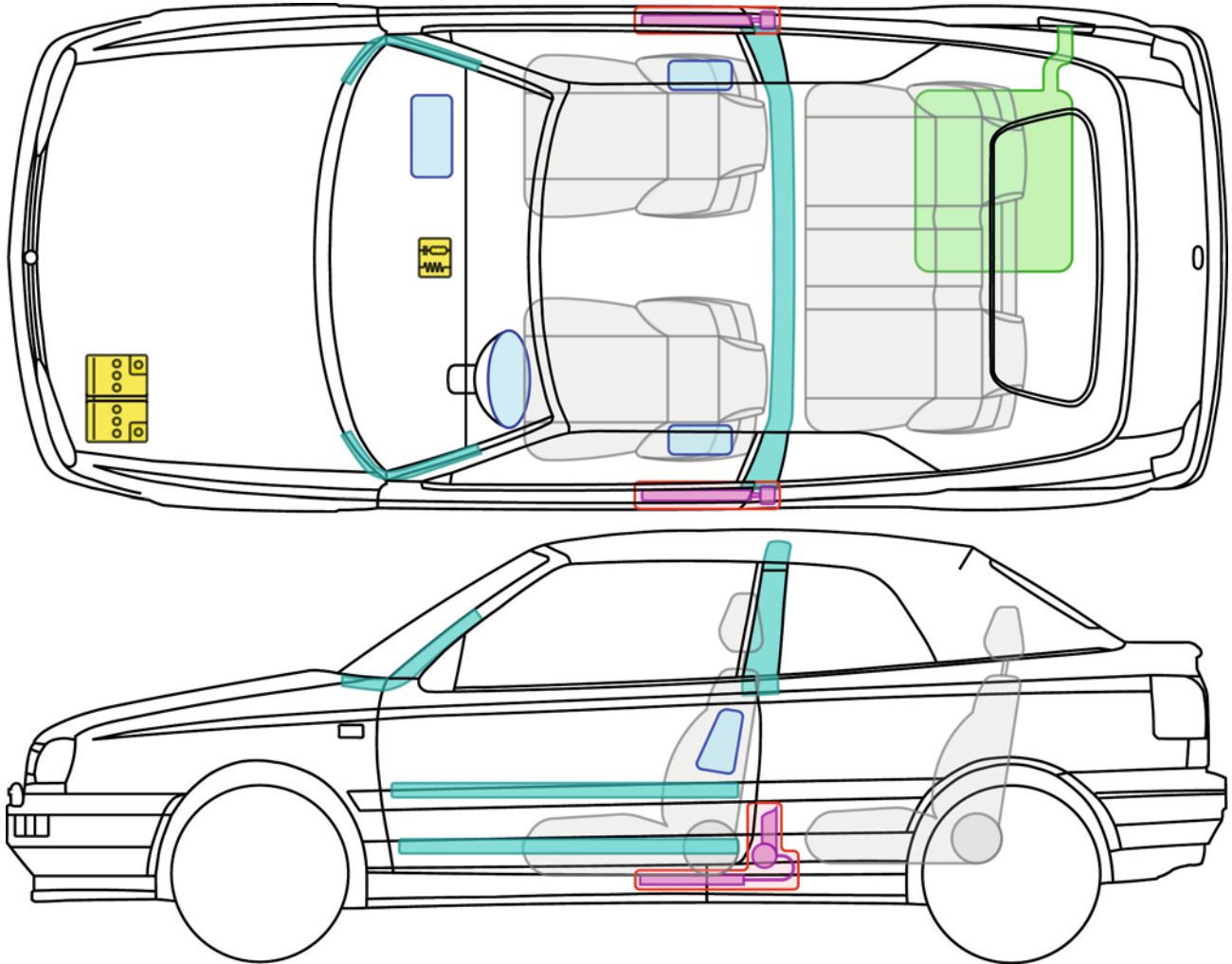

Golf 3

(Cabrio, 1993 - 1998)



Legende

	Airbag		Karosserie-Verstärkung		Steuergerät
					12 V-Batterie
	Gurtstraffer				Kraftstofftank



Golf 3 (Cabrio, 1993 - 1998)







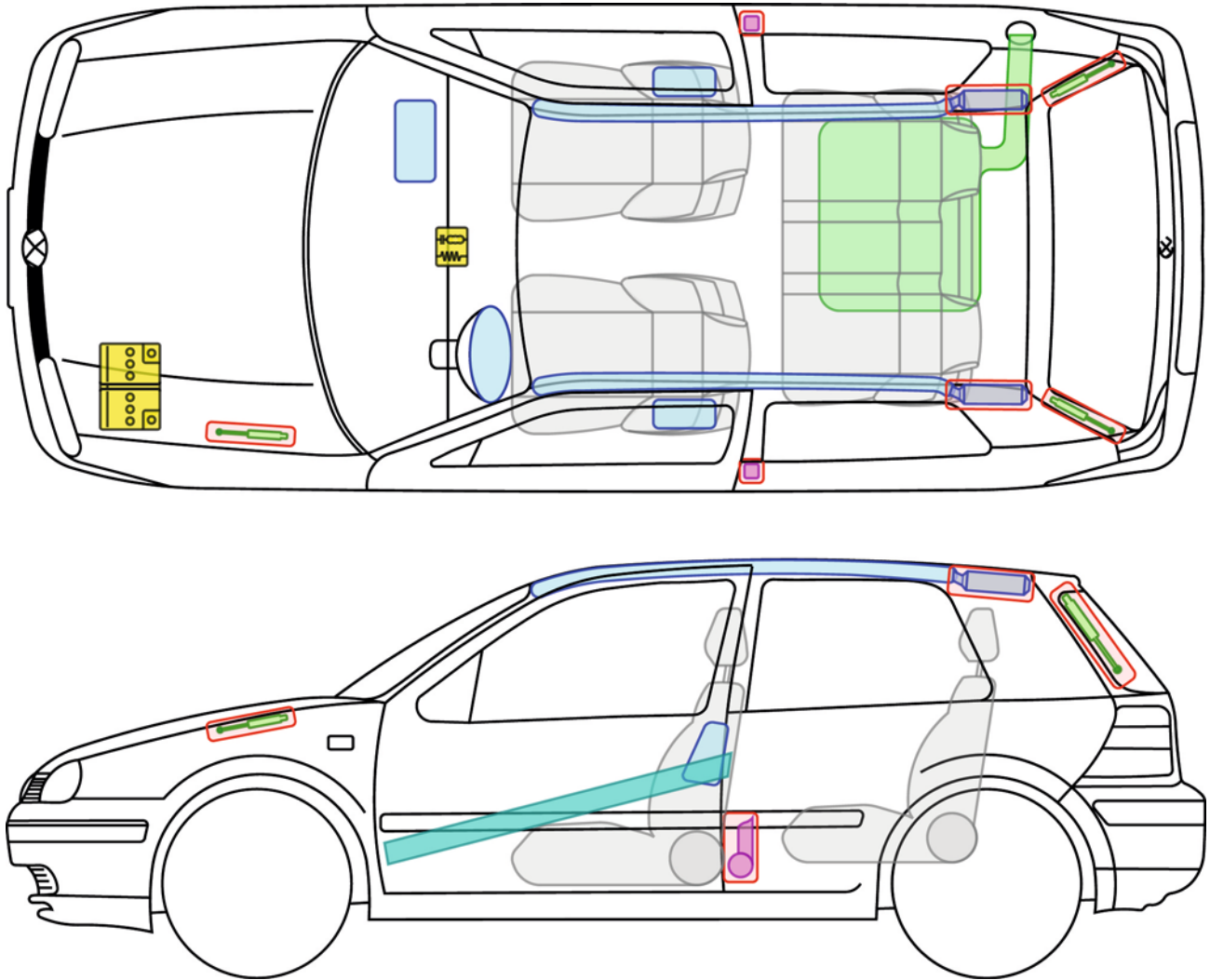



Golf 4

(3-Türer, 1997 - 2003)



Legende

	Airbag		Karosserie-Verstärkung		Steuergerät	
	Gas-generator				12 V-Batterie	
	Gurtstraffer		Gasdruck-dämpfer		Kraftstofftank	







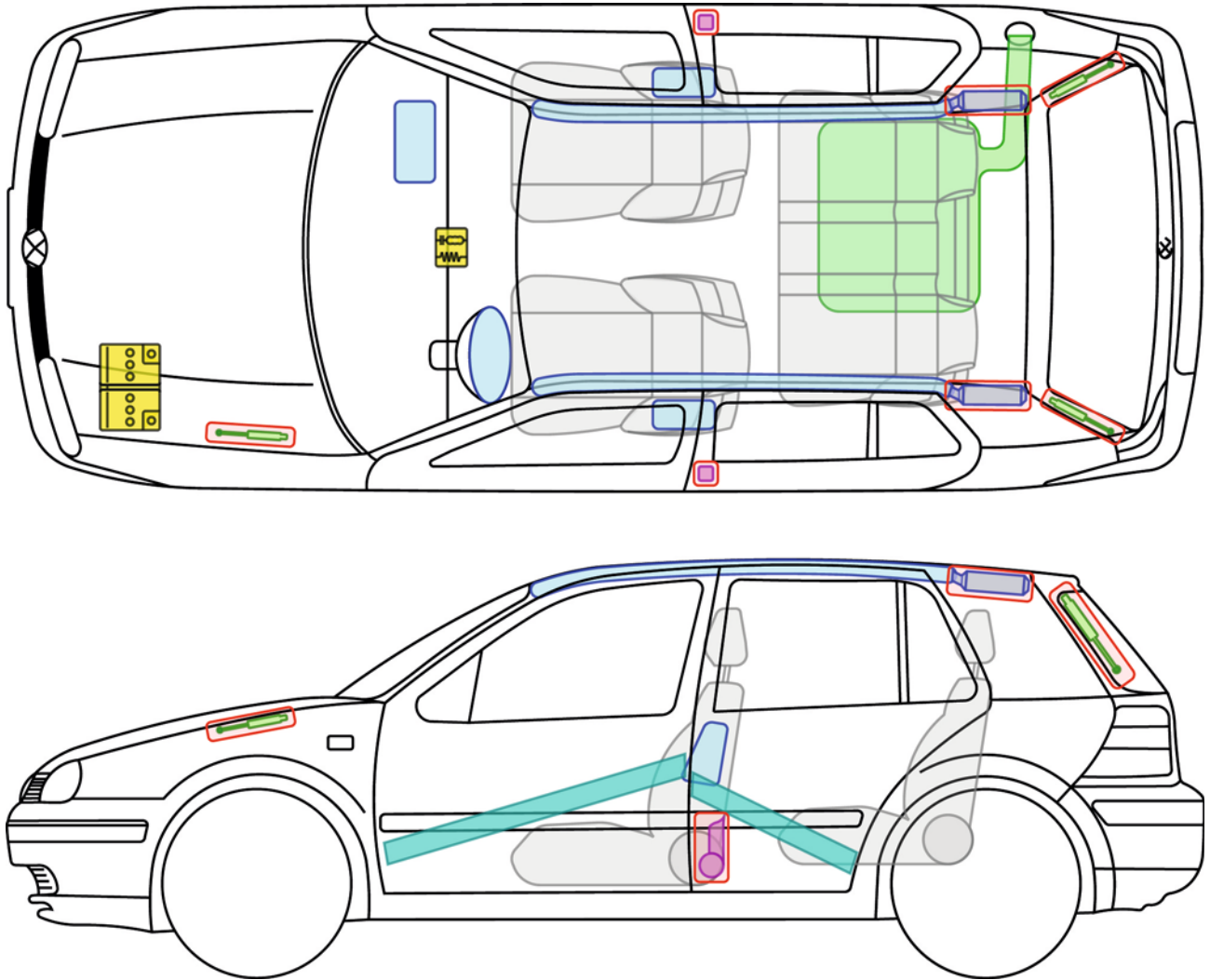



Golf 4

(5-Türer, 1997 - 2003)



Legende

	Airbag		Karosserie-Verstärkung		Steuergerät	
	Gas-generator				12 V-Batterie	
	Gurtstraffer		Gasdruck-dämpfer		Kraftstofftank	







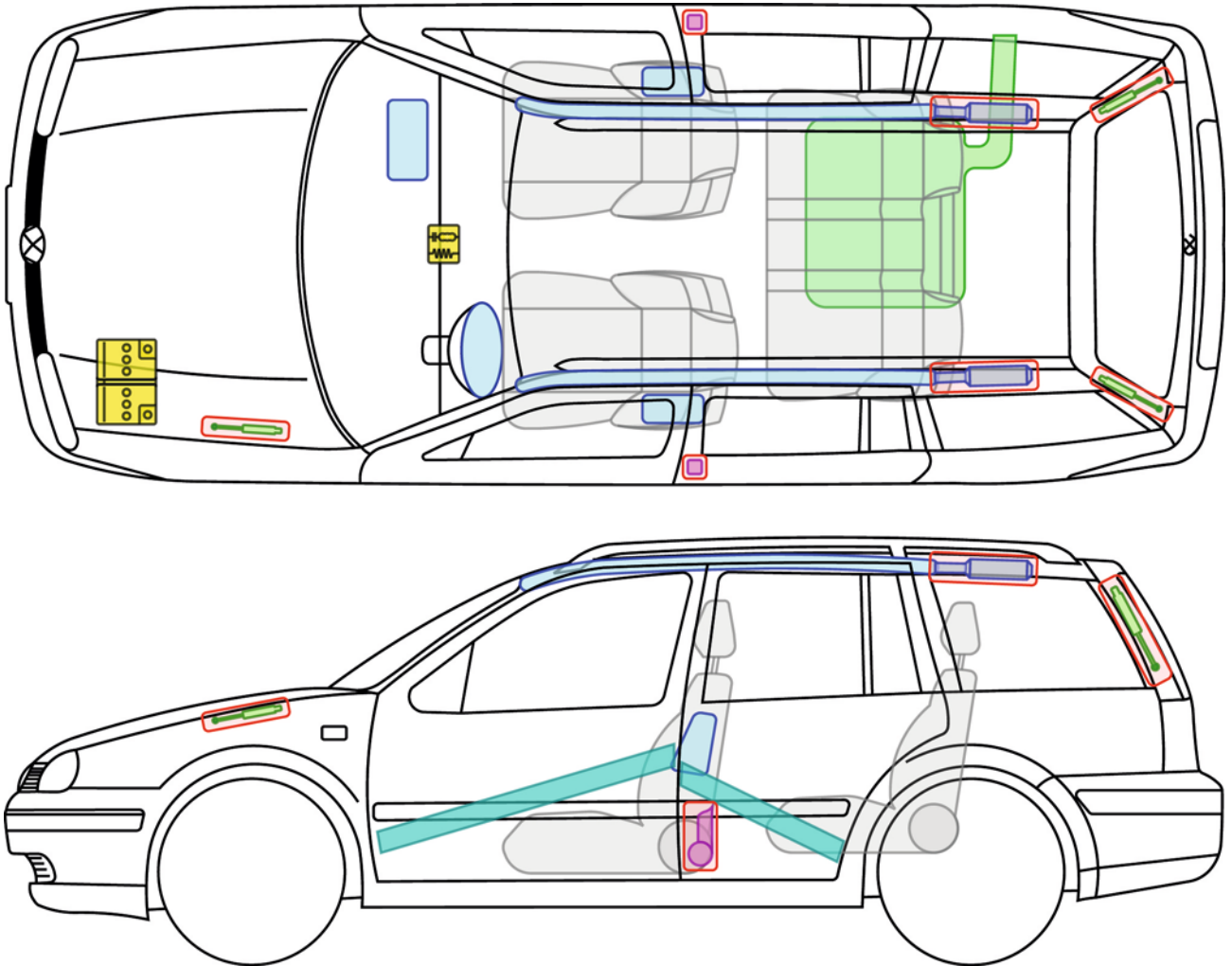



Golf 4

(Variant, 1999 - 2003)



Legende

	Airbag		Karosserie-Verstärkung		Steuergerät
	Gas-generator				12V-Batterie
	Gurtstraffer		Gasdruck-dämpfer		Kraftstofftank



Golf 4 (Variant, 1999 - 2003)







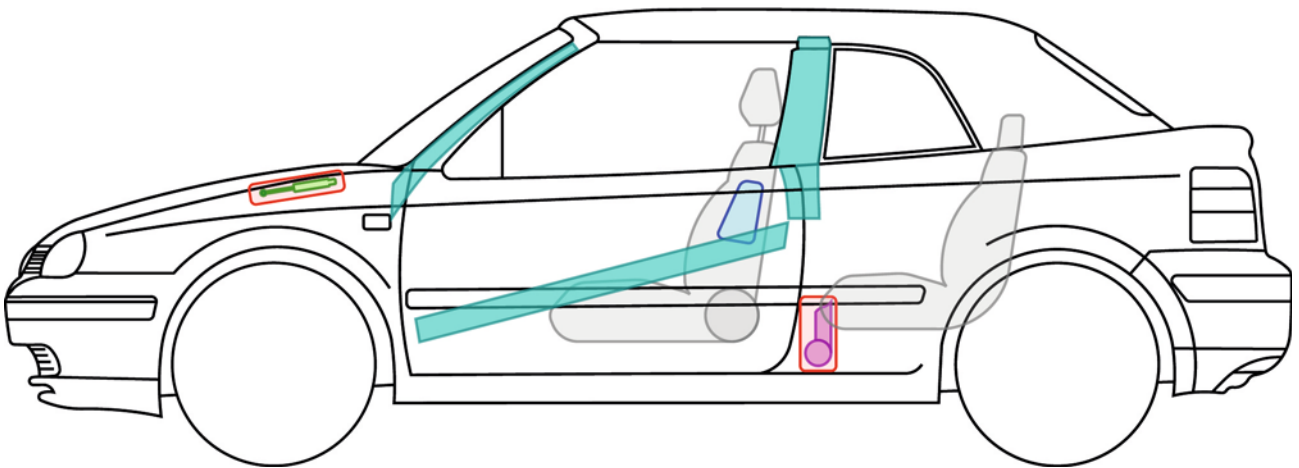
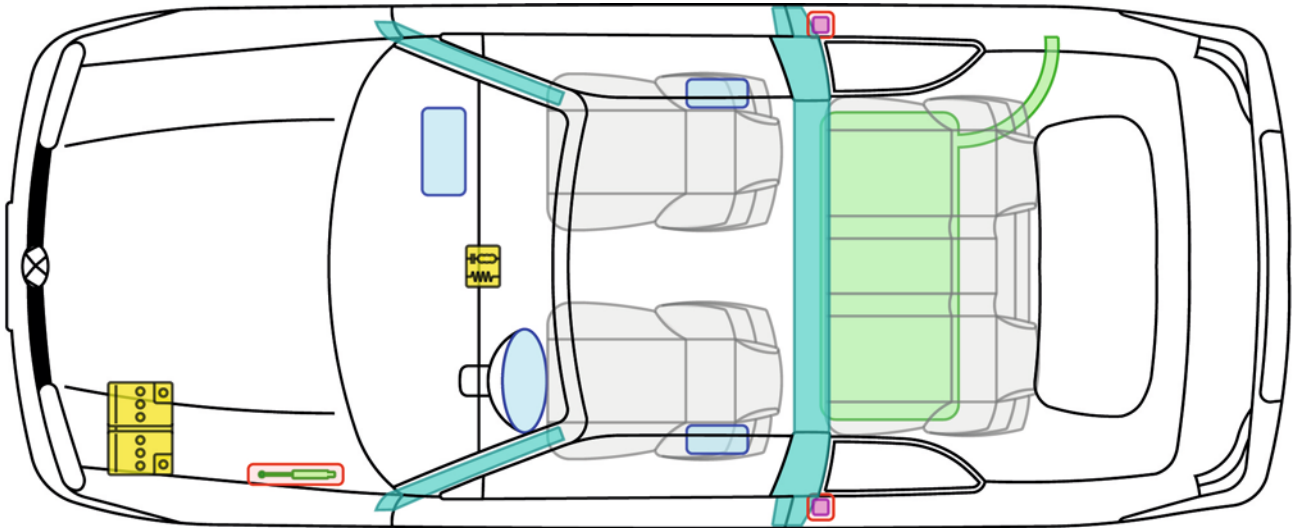

Golf 4

(Cabrio, 1998 - 2002)

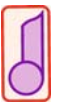

Legende

	Airbag		Karosserie-Verstärkung		Steuergerät
					12 V-Batterie
	Gurtstraffer		Gasdruck-dämpfer		Kraftstofftank



Golf 4 (Cabrio, 1998 - 2002)



Golf 4

(Variant BiFuel, 2003-06)

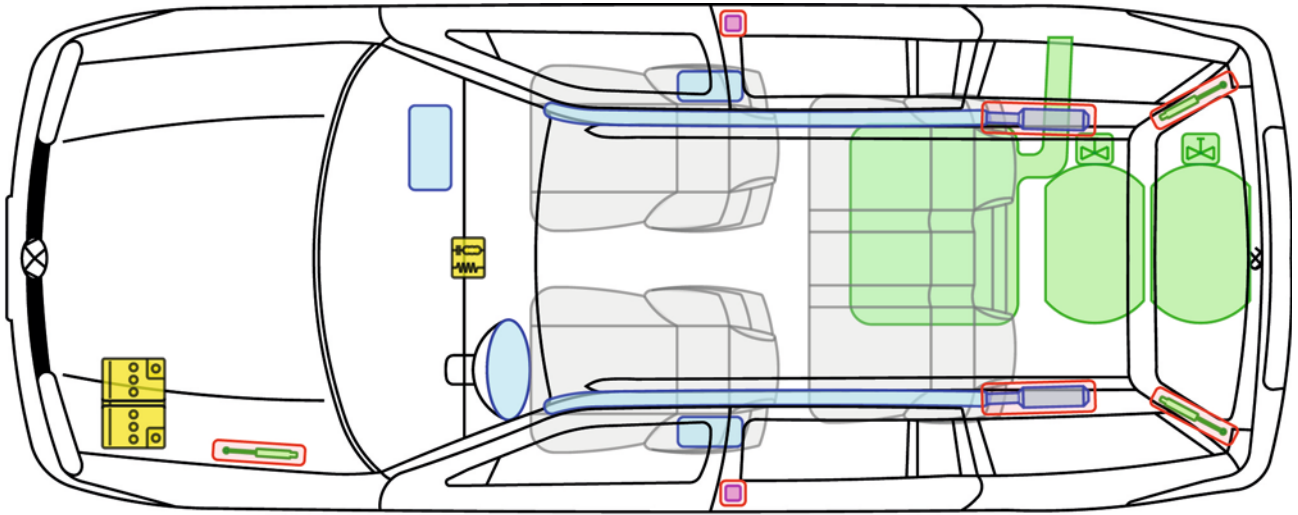





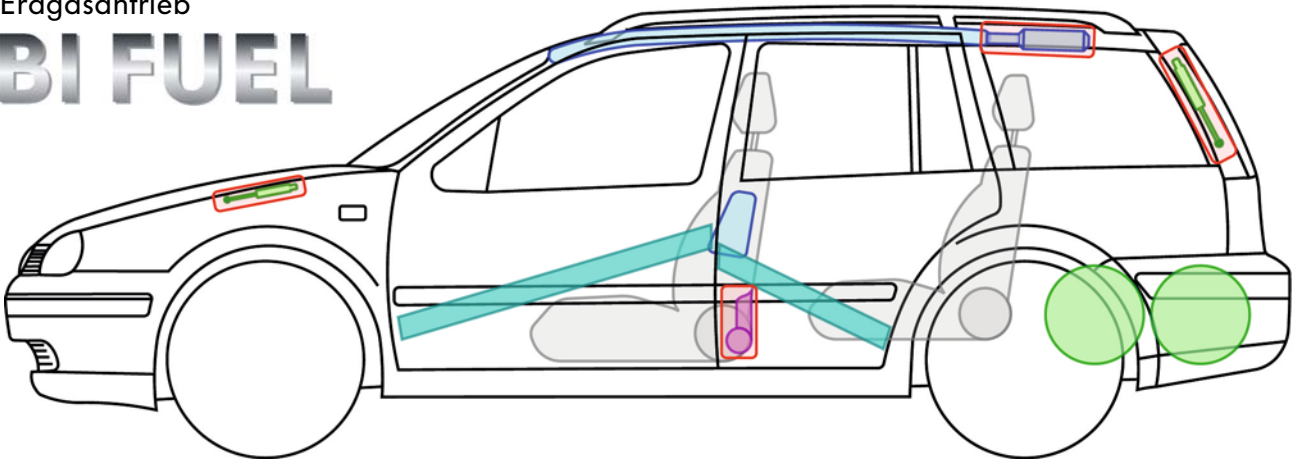





Erdgasantrieb

BI FUEL



Legende

	Airbag		Karosserie-Verstärkung		Steuergerät		Gastank
	Gas-generator				12V-Batterie		Sicherheits-ventil
	Gurtstraffer		Gasdruck-dämpfer		Kraftstofftank		



Golf 4 (Variant BiFuel, 2003 - 2006)



Golf 4

(Variant BiFuel, 2003-06)



Hinweise zur Erdgasanlage

Gastanks manuell absperren (bei Gasgeruch bzw. Austritt von Erdgas)

1. Zugang zu den Erdgastanks

- Sie sind unter dem Ladeboden im Kofferraum montiert.
- Zum Hochklappen des Ladebodens die beiden Arretierungsschrauben an der hinteren Kante des Ladebodens gegen den Uhrzeigersinn lösen.



die Gastanks unter dem Ladeboden

2. Absperrhähne lokalisieren

- Jeder Gastank besitzt ein eigenes Flaschenventil mit einem manuellen Absperrhahn.
- Falls einsatzbedingt erforderlich muss jeder Gastank separat abgesperrt werden.

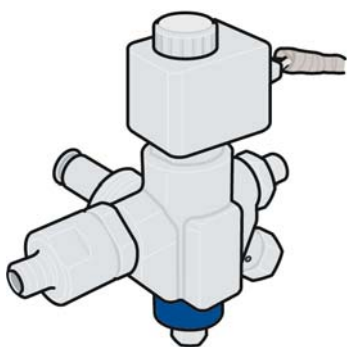

manueller Absperrhahn am Fuß des Flaschenventils.

3. Gastank von Hand schließen

- Falls einsatzbedingt erforderlich muss jeder Gastank separat abgesperrt werden.
- Mit einem 5er-Maul- bzw. Ringschlüssel lässt sich das manuelle Absperrventil am Vierkant durch Drehen im Uhrzeigersinn bis zum Anschlag des Ventils verschließen.

i Der Begriff „BiFuel“ wurde bei Einführung von gasbetriebenen Fahrzeugen auch für Erdgasfahrzeuge verwendet. Seit 2009 wird der Begriff „EcoFuel“ für Erdgasfahrzeuge und der Begriff „BiFuel“ für Autogasfahrzeuge (Flüssiggasfahrzeuge) benutzt.







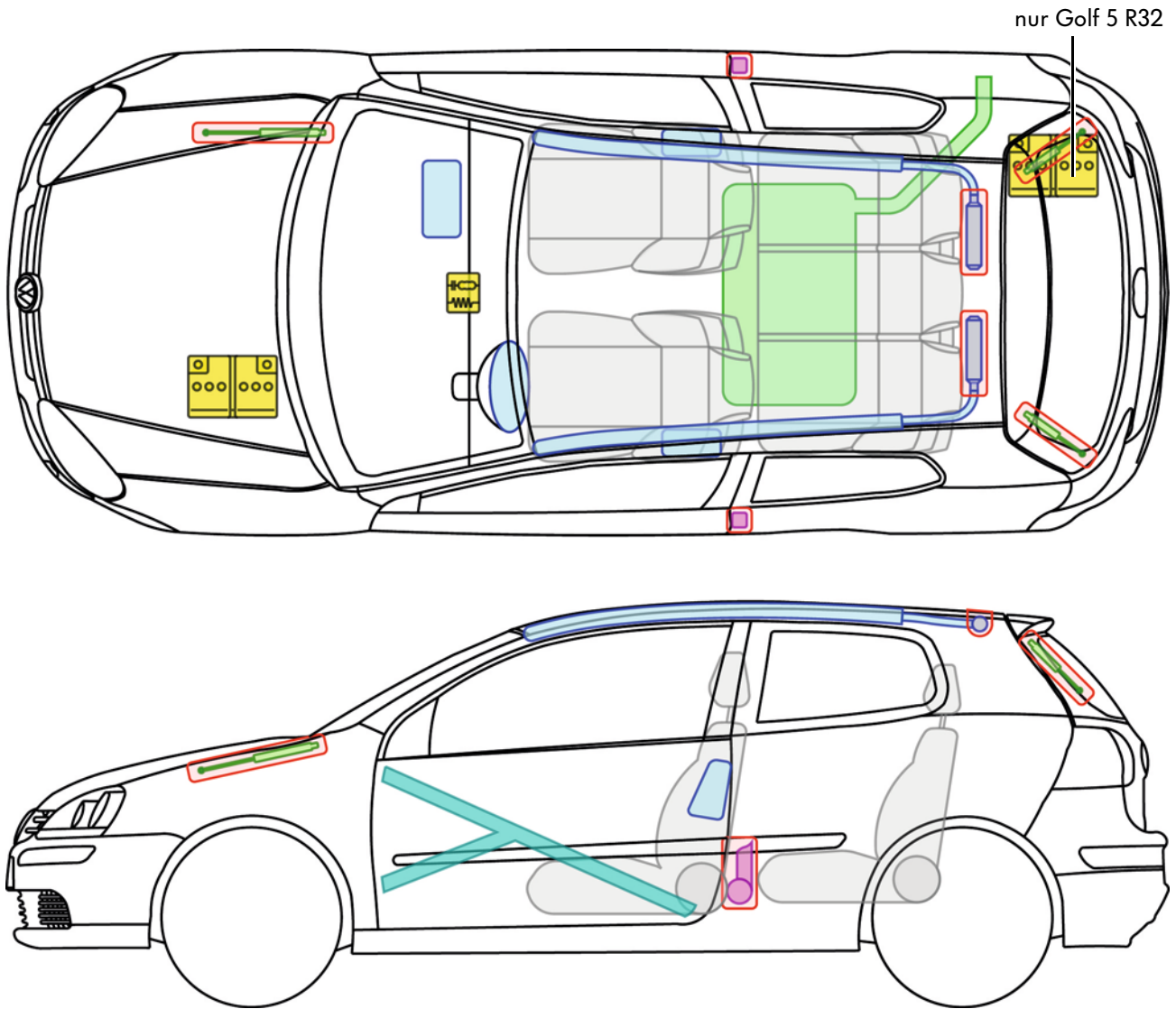



Golf 5

(3-Türer, 2003 - 2008)



Legende

	Airbag		Karosserie-Verstärkung		Steuergerät	
	Gas-generator				12 V-Batterie	
	Gurtstraffer		Gasdruckdämpfer		Kraftstofftank	



Golf 5

(3-Türer, 2003 - 2008)



Fahrzeug deaktivieren

Batterie abklemmen (gilt nur bei Golf 5 R32)

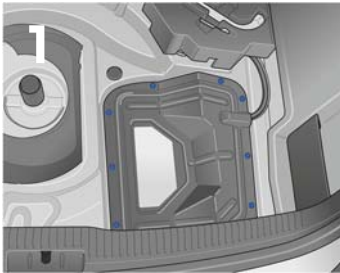

1. Batterieabdeckung im Kofferraum entfernen

- Batterieabdeckung im Kofferraumboden auf der rechten Fahrzeugseite lokalisieren
- Befestigungsschrauben lösen und Abdeckung abnehmen



2. Masseanschluss (-) an der Batterie abklemmen

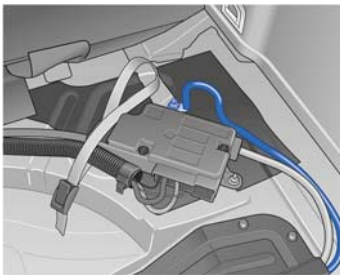

Optionale Methode: Massekontakt an der Karosserie lösen

- Massekontakt auf dem Kofferraumboden unter dem Bordwerkzeug lokalisieren
- Massekontakt mit geeignetem Werkzeug lösen und abziehen









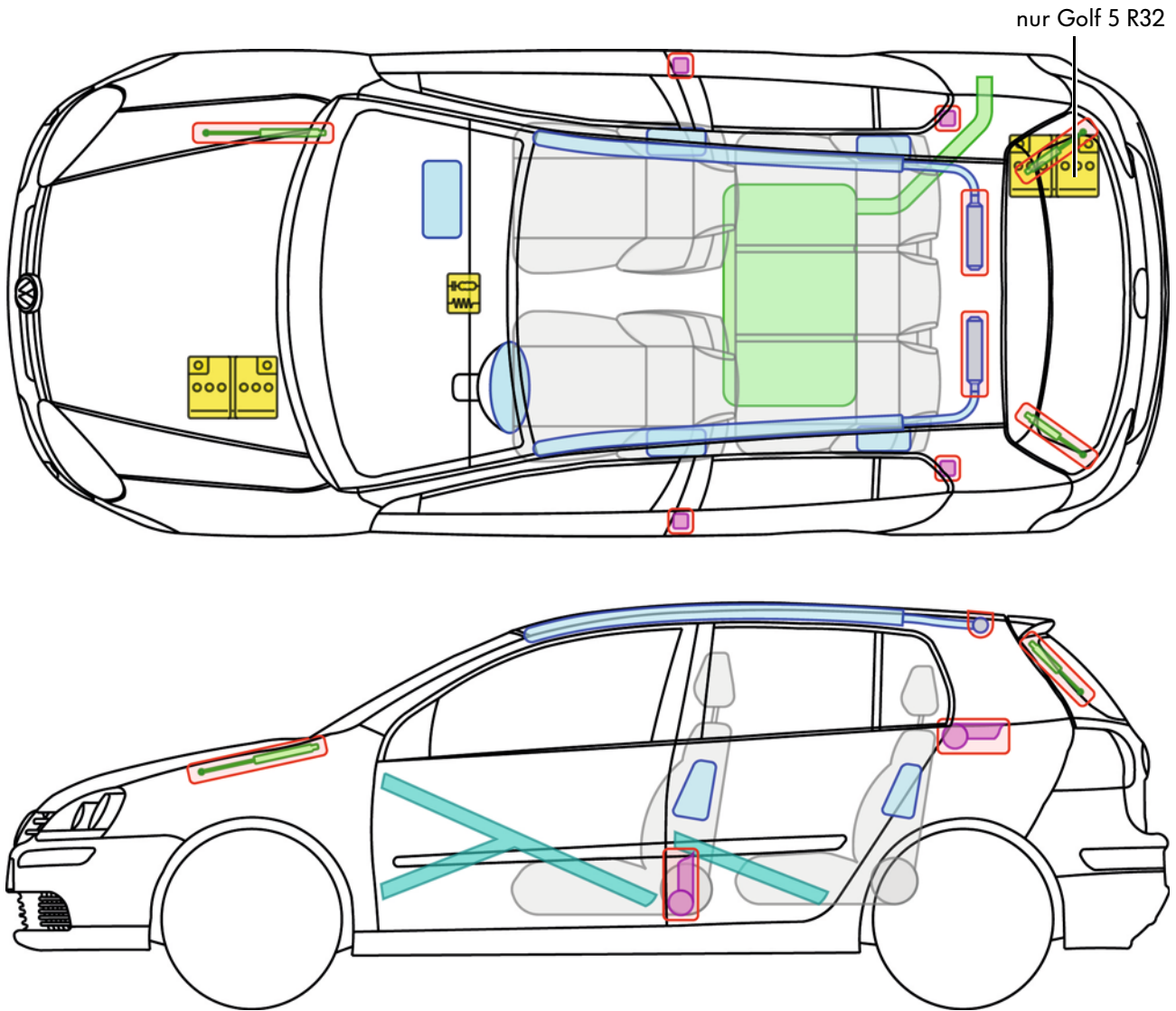



Golf 5

(5-Türer, 2003 - 2008)



Legende

	Airbag		Karosserie-Verstärkung		Steuergerät	
	Gas-generator				12 V-Batterie	
	Gurtstraffer		Gasdruck-dämpfer		Kraftstofftank	



Golf 5

(5-Türer, 2003 - 2008)



Fahrzeug deaktivieren

Batterie abklemmen (nur bei Golf 5 R32)

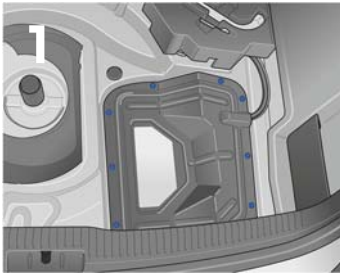

1. Batterieabdeckung im Kofferraum entfernen

- Batterieabdeckung im Kofferraumboden auf der rechten Fahrzeugseite lokalisieren
- Befestigungsschrauben lösen und Abdeckung abnehmen



2. Masseanschluss (-) an der Batterie abklemmen

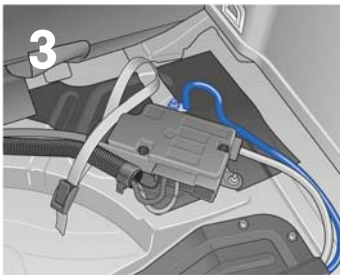

Optionale Methode: Massekontakt an der Karosserie lösen

- Massekontakt auf dem Kofferraumboden unter dem Bordwerkzeug lokalisieren
- Massekontakt mit geeignetem Werkzeug lösen und abziehen









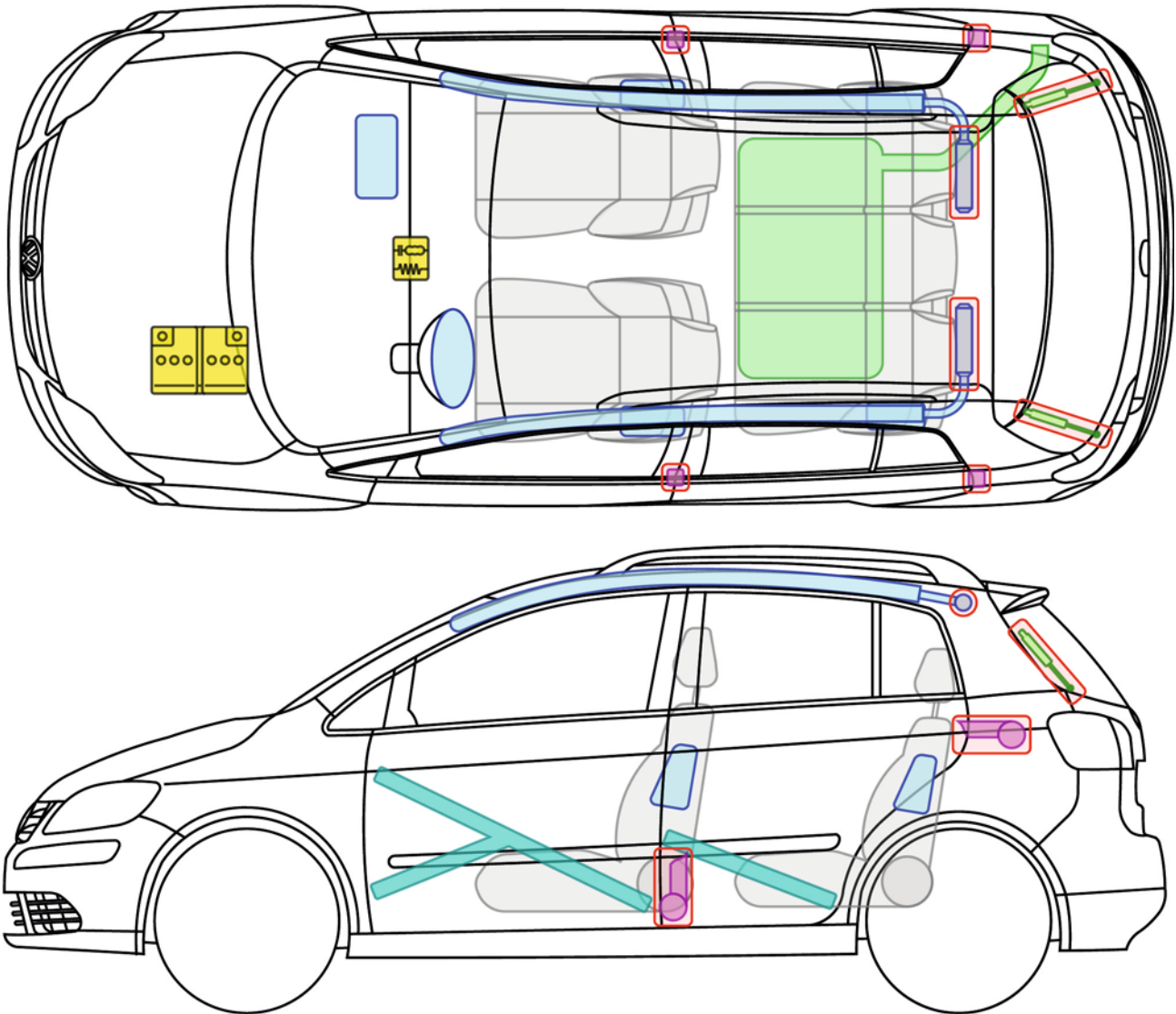



Golf 5 Plus

(2005 - 2009)



Legende

	Airbag		Karosserie-Verstärkung		Steuergerät
	Gas-generator				12V-Batterie
	Gurtstraffer		Gasdruck-dämpfer		Kraftstofftank

G

Golf 5 Plus (2005 - 2009)







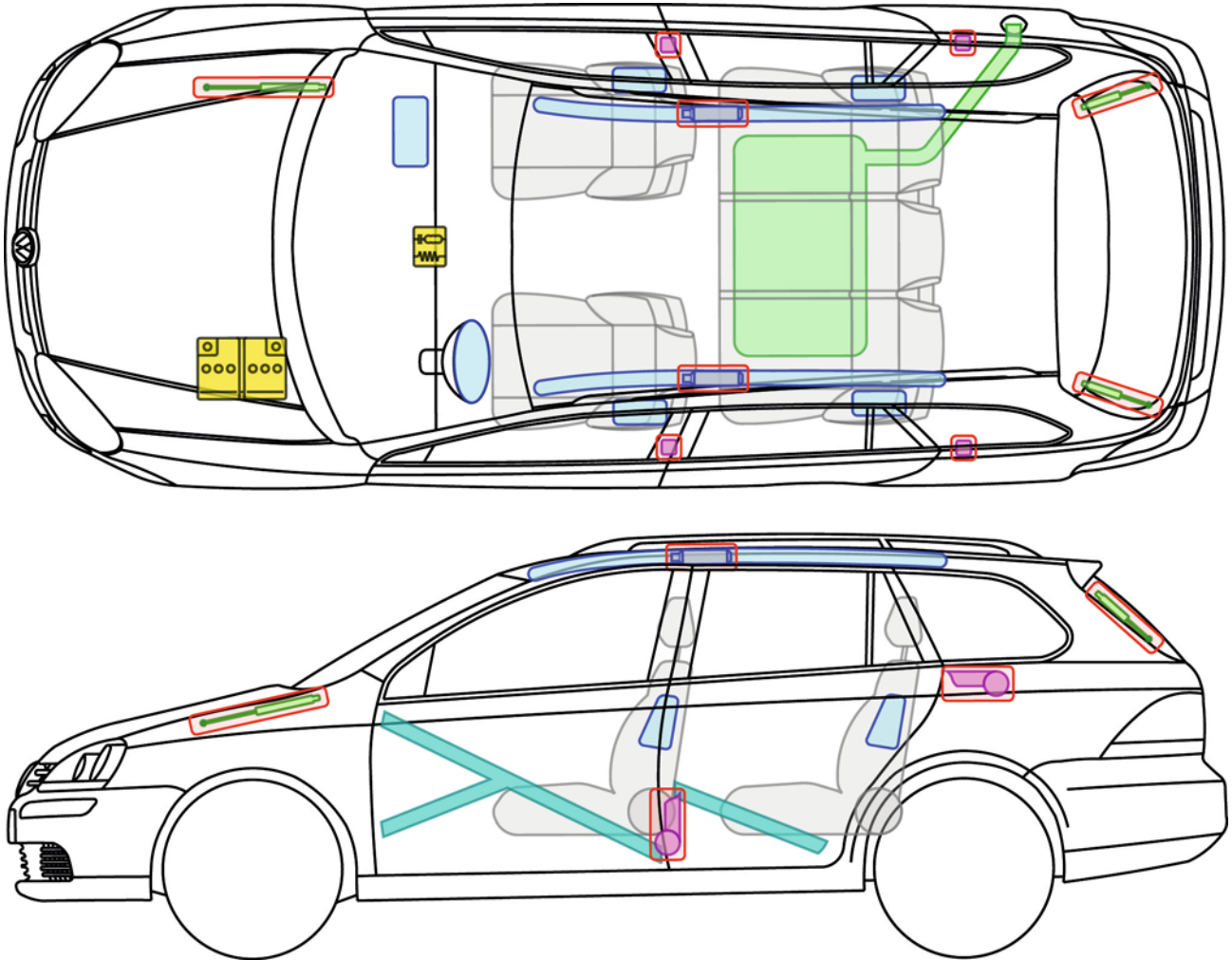



Golf 5

(Variant, 2006 - 2009)



Legende

	Airbag		Karosserie-Verstärkung		Steuergerät
	Gas-generator				12 V-Batterie
	Gurtstraffer		Gasdruck-dämpfer		Kraftstofftank



Golf 5 (Variant, 2006 - 2009)







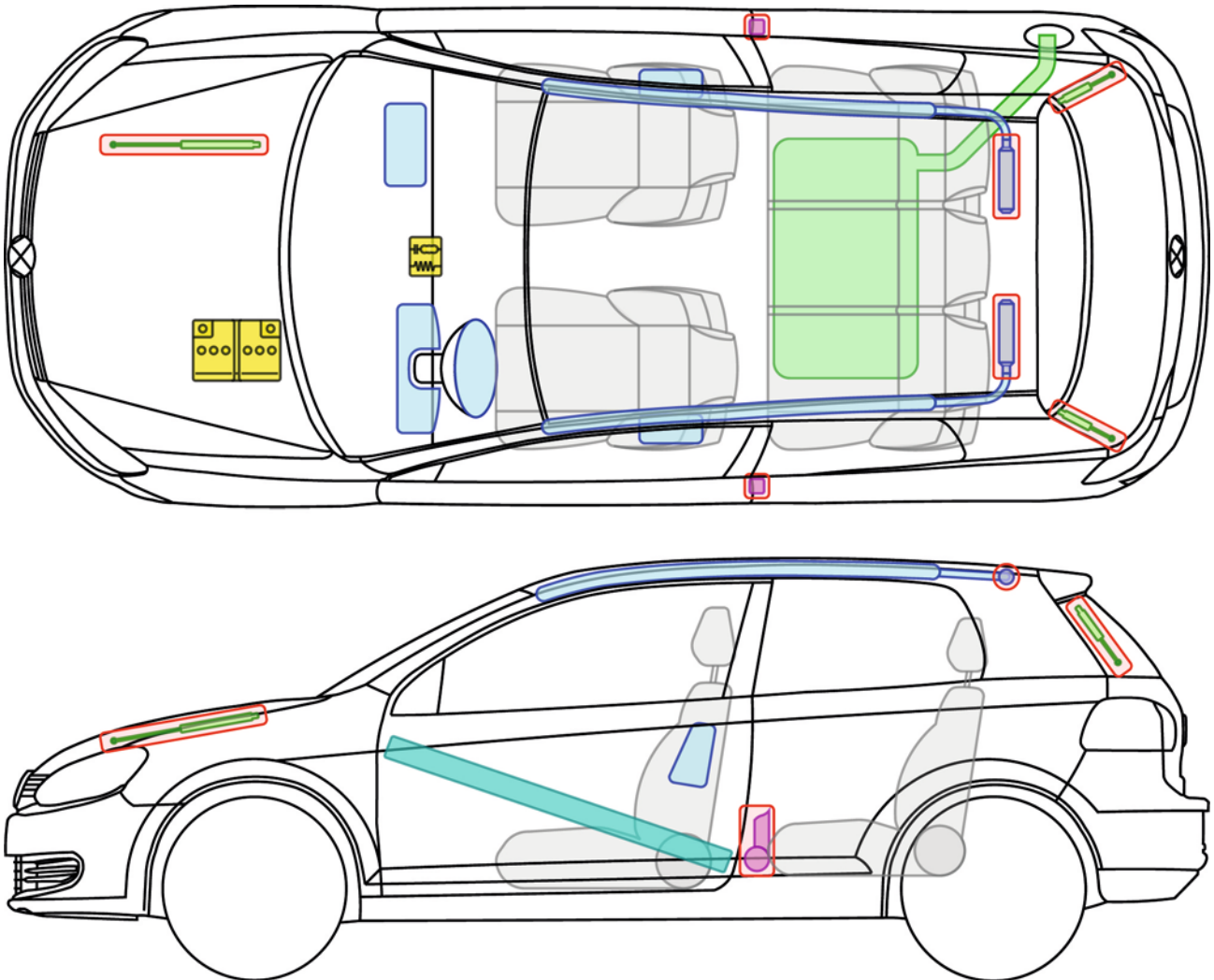



Golf 6

(3-Türer, ab 2008)



Legende

	Airbag		Karosserie-Verstärkung		Steuergerät
	Gas-generator				12 V-Batterie
	Gurtstraffer		Gasdruck-dämpfer		Kraftstofftank







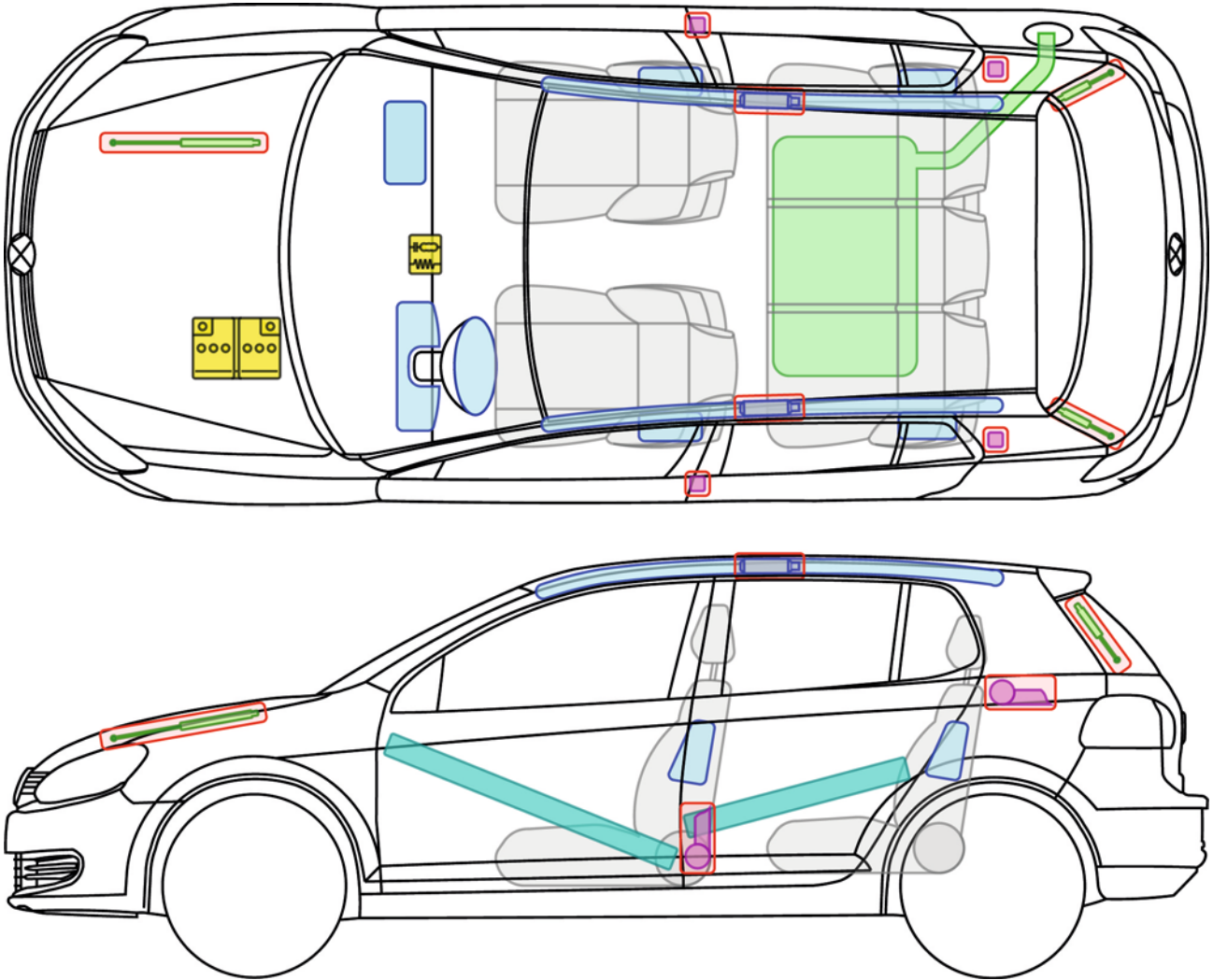



Golf 6

(5-Türer, ab 2008)



Legende

	Airbag		Karosserie-Verstärkung		Steuergerät
	Gas-generator				12 V-Batterie
	Gurtstraffer		Gasdruck-dämpfer		Kraftstofftank



Golf 6

(3-Türer BiFuel, ab 2009)

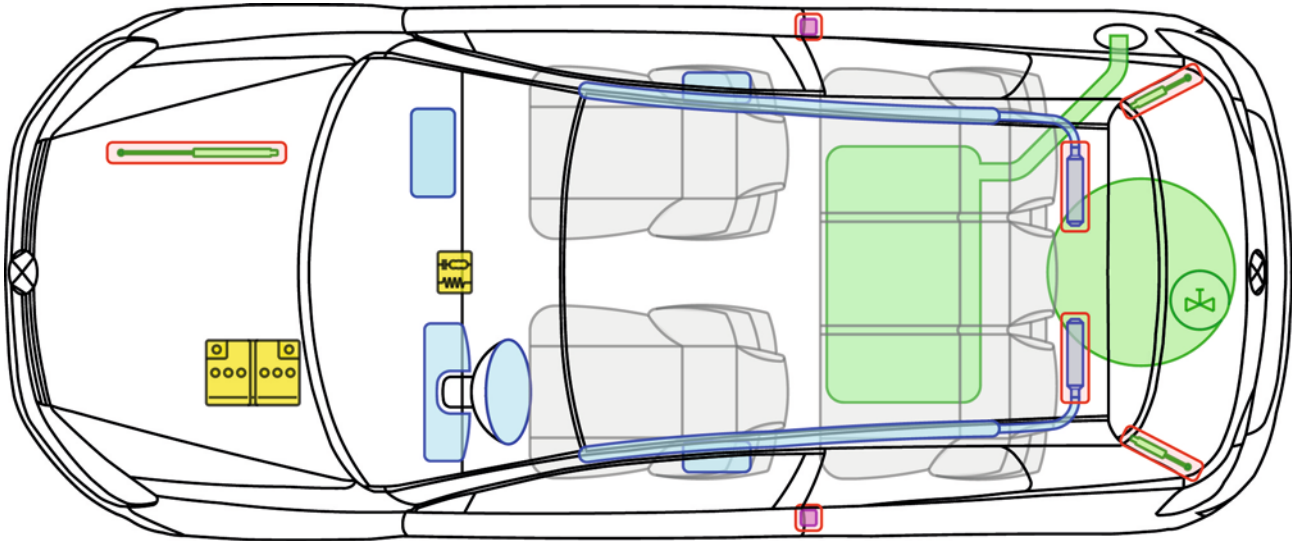





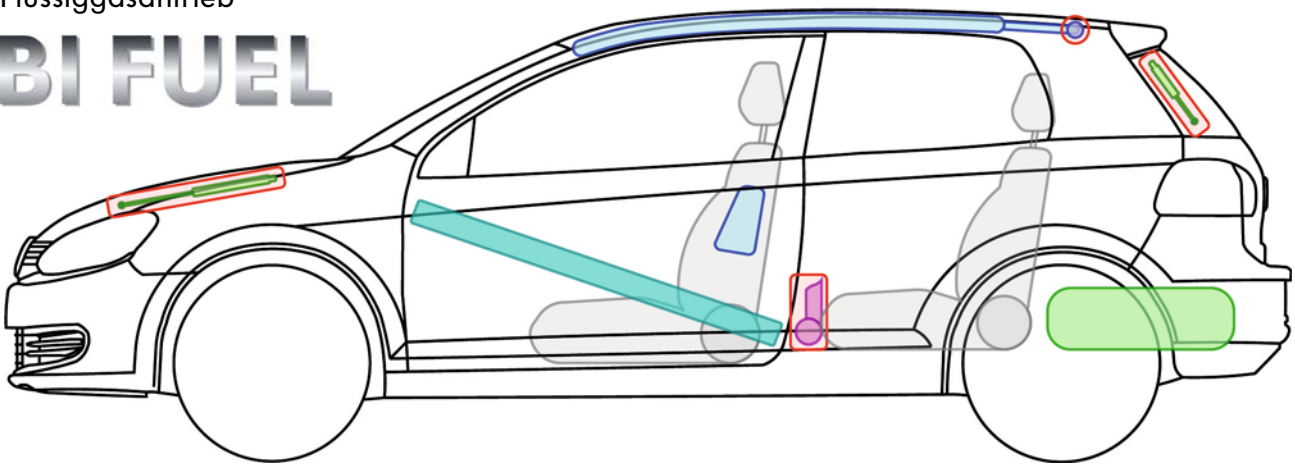

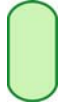

Flüssiggasantrieb

BI FUEL



Legende

	Airbag		Karosserie-Verstärkung		Steuergerät		Gastank
	Gas-generator				12 V-Batterie		Sicherheits-ventil
	Gurtstraffer		Gasdruck-dämpfer		Kraftstofftank		



Golf 6 (3-Türer BiFuel, ab 2009)



Golf 6

(3-Türer BiFuel, ab 2009)



Hinweise zur Flüssiggasanlage

Der Gastank der Flüssiggasanlage des Golf 6 BiFuel hat keine mechanische, manuelle Absperrmöglichkeit!



Der Flüssiggastank in der Reserveradmulde

1. Flüssiggastank lokalisieren

- Er ist unter dem Ladeboden in der Reserveradmulde montiert.
- Der Gastank verfügt nur über ein elektromagnetisches Absperrventil, das stromlos geschlossen ist.





Golf 6

(5-Türer BiFuel, ab 2009)

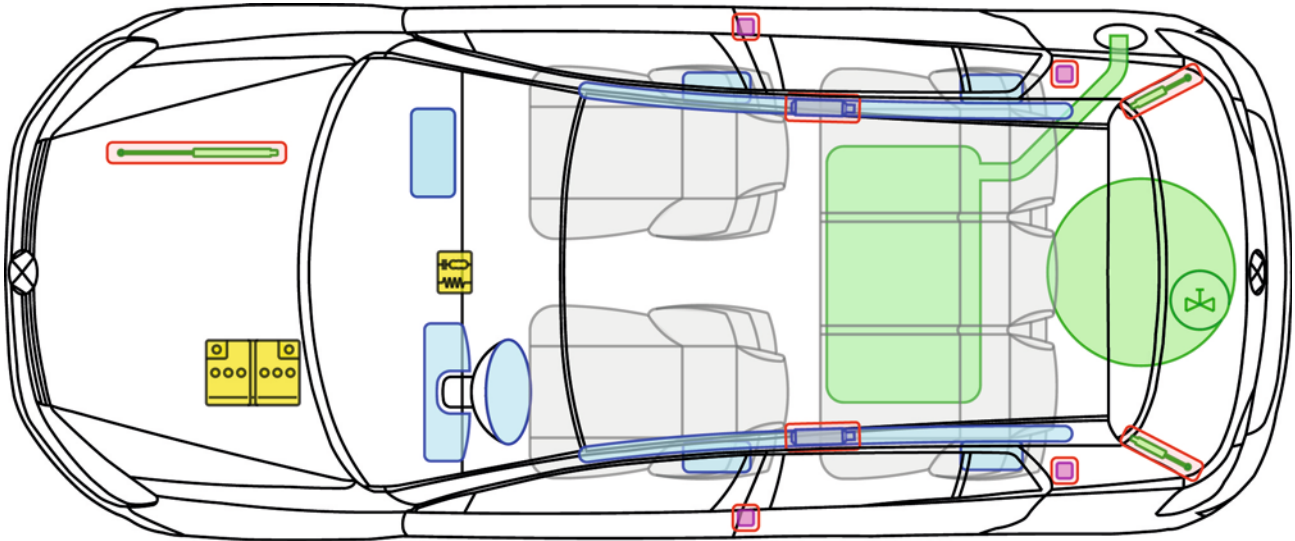





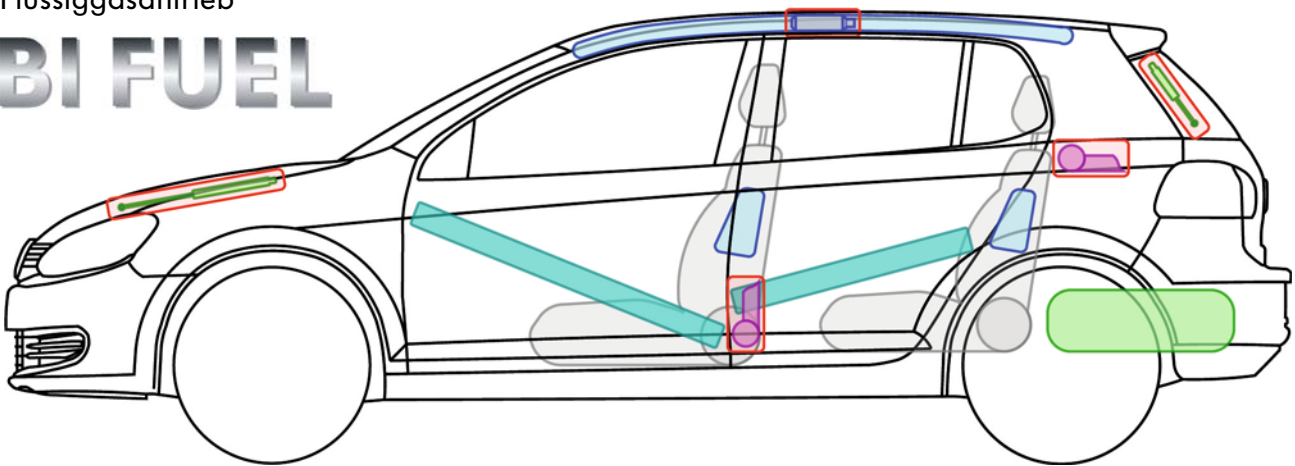

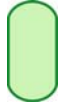

Flüssiggasantrieb

BI FUEL



Legende

	Airbag		Karosserie-Verstärkung		Steuergerät		Gastank
	Gas-generator				12 V-Batterie		Sicherheits-ventil
	Gurtstraffer		Gasdruck-dämpfer		Kraftstofftank		



Golf 6 (5-Türer BiFuel, ab 2009)



Golf 6

(5-Türer BiFuel, ab 2009)



Hinweise zur Flüssiggasanlage

Der Gastank der Flüssiggasanlage des Golf 6 BiFuel hat keine mechanische, manuelle Absperrmöglichkeit!



Der Flüssiggastank in der Reserveradmulde

1. Flüssiggastank lokalisieren

- Er ist unter dem Ladeboden in der Reserveradmulde montiert.
- Der Gastank verfügt nur über ein elektromagnetisches Absperrventil, das stromlos geschlossen ist.









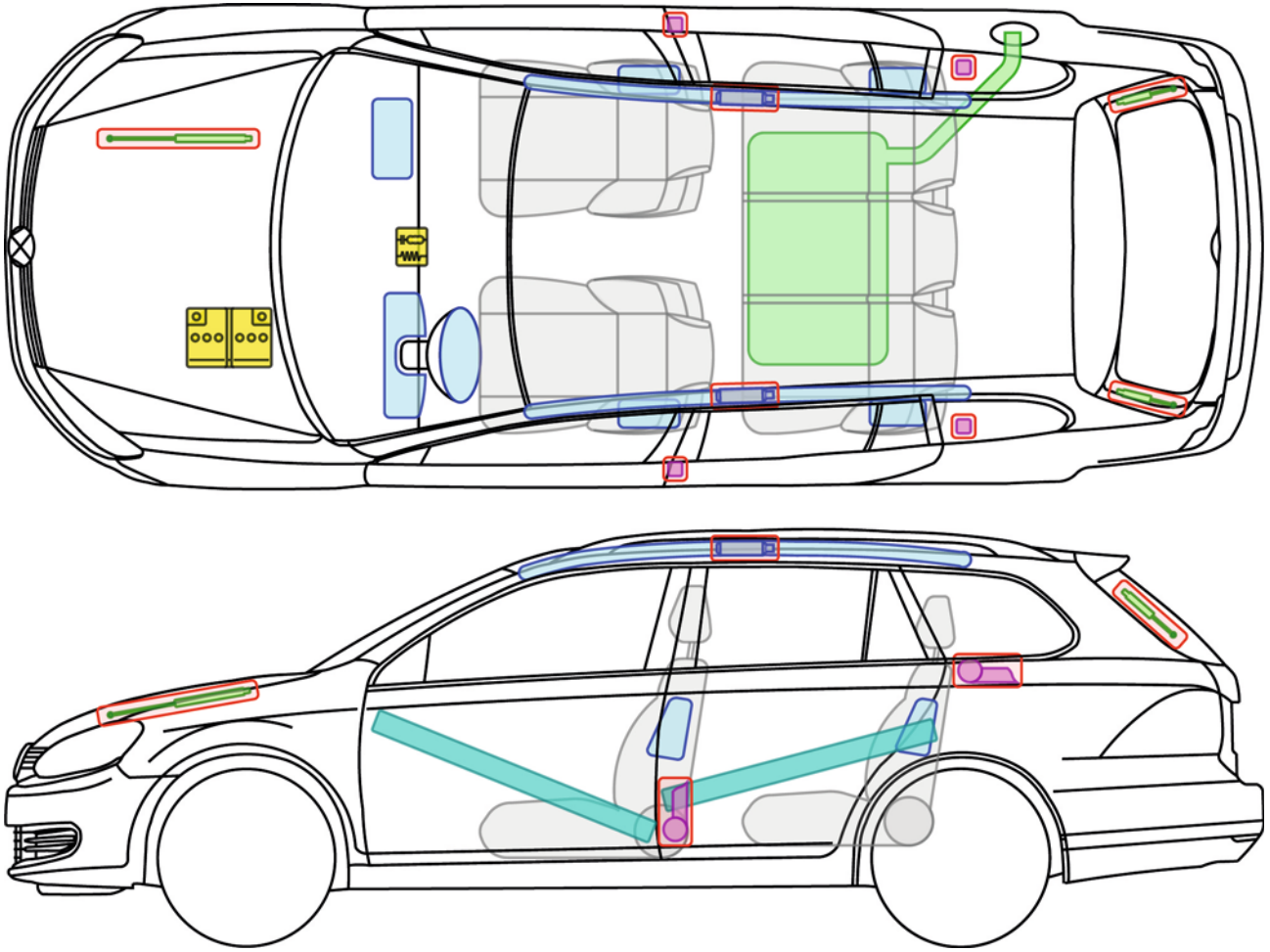



Golf 6

(Variant, ab 2009)



Legende

	Airbag		Karosserie-Verstärkung		Steuergerät	
	Gas-generator				12 V-Batterie	
	Gurtstraffer		Gasdruck-dämpfer		Kraftstofftank	



Golf 6 (Variant, ab 2009)







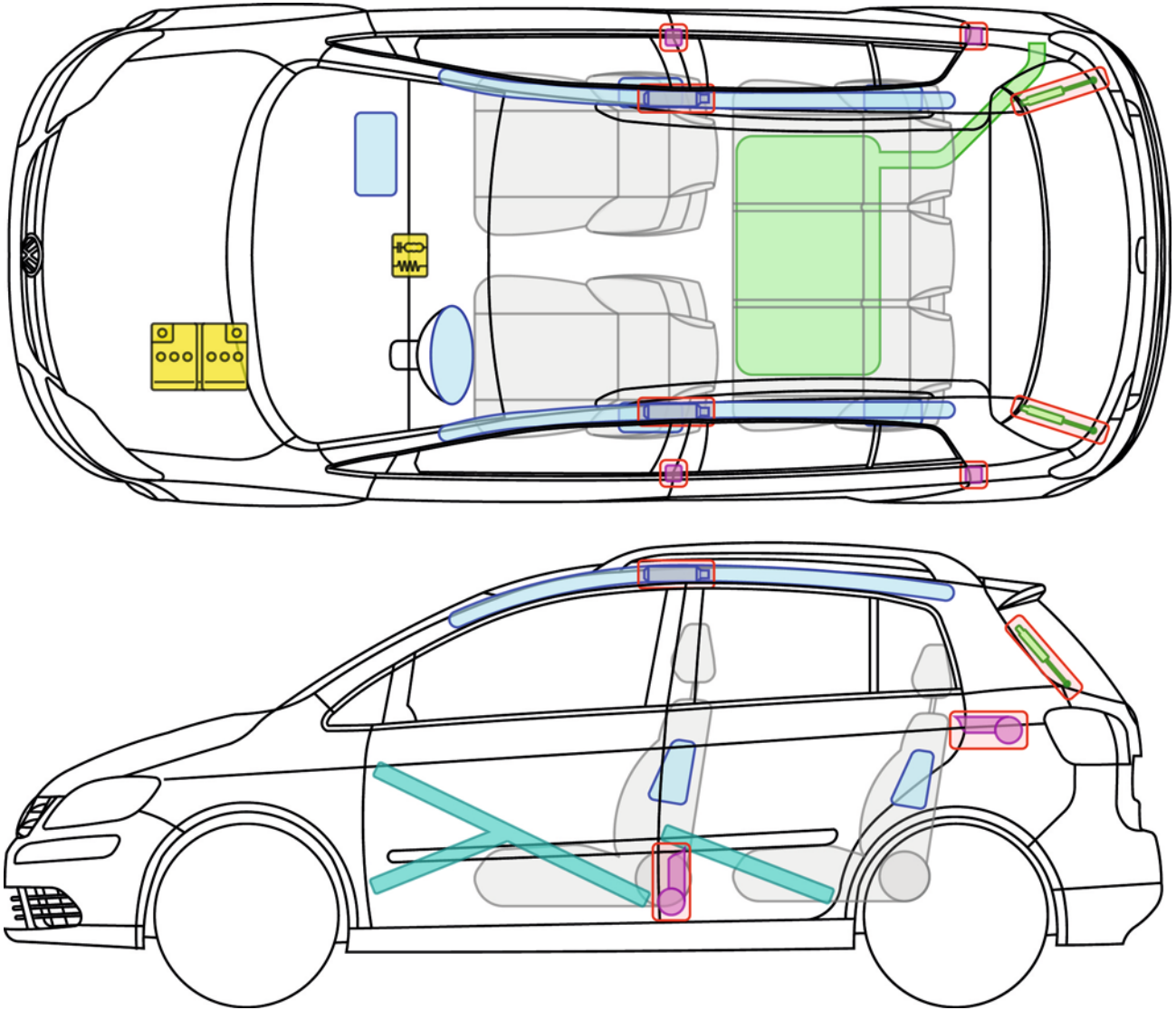



Golf 6 Plus

(ab 2009)



Legende

	Airbag		Karosserie-Verstärkung		Steuergerät
	Gas-generator				12V-Batterie
	Gurtstraffer		Gasdruck-dämpfer		Kraftstofftank



Golf 6 Plus (ab 2009)



Golf 6 Plus

(BiFuel, ab 2009)

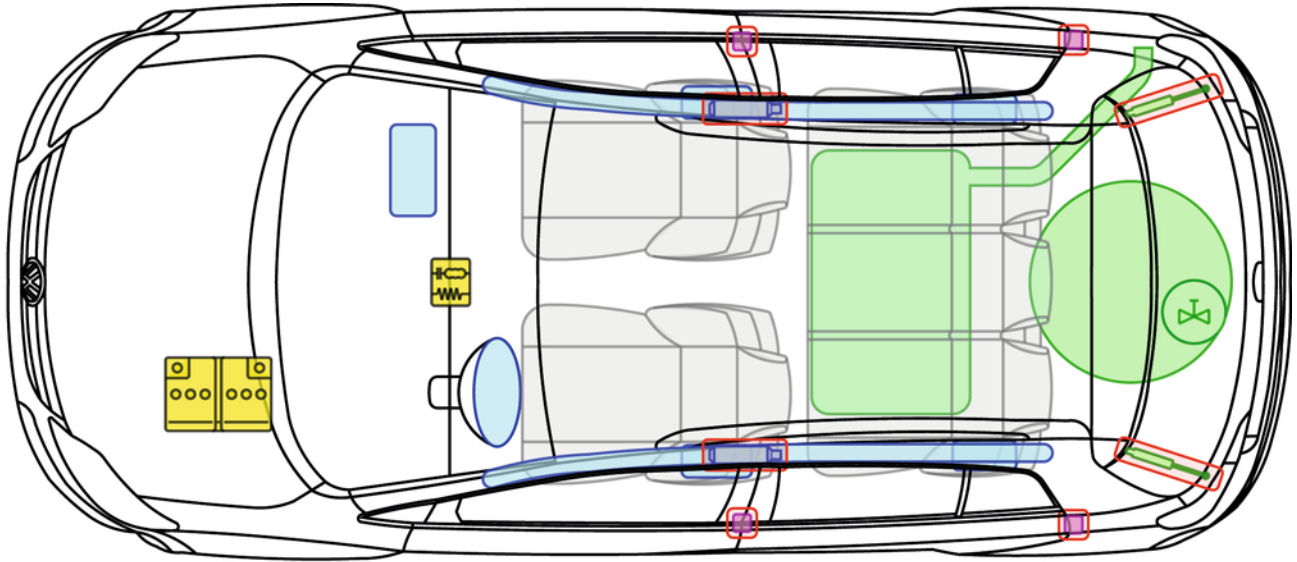





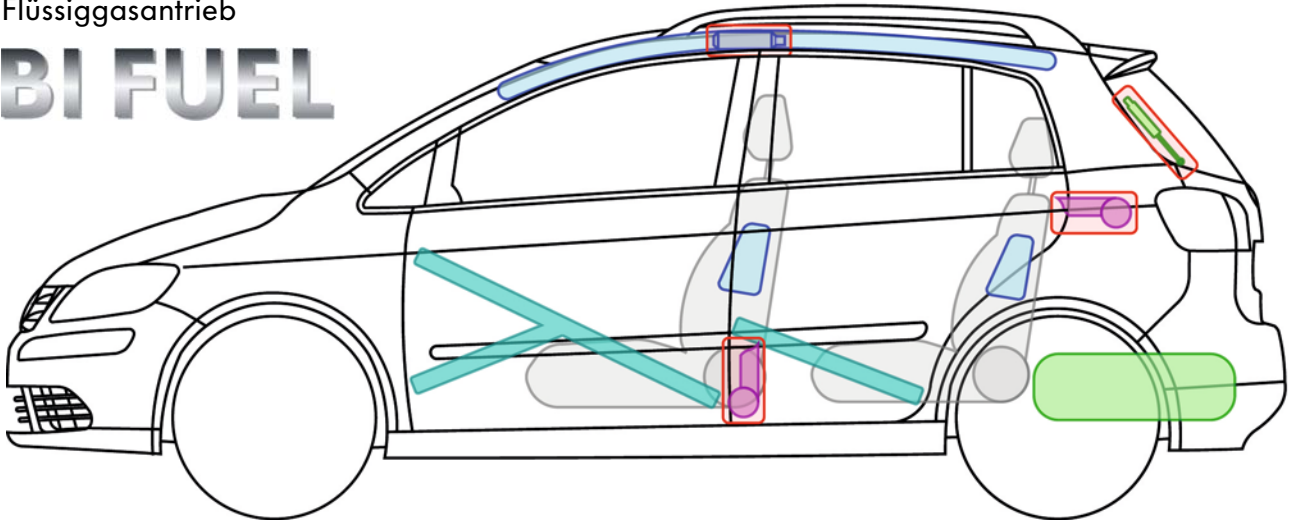

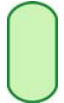

Flüssiggasantrieb

BI FUEL



Legende

	Airbag		Karosserie-Verstärkung		Steuergerät		Gastank
	Gas-generator				12 V-Batterie		Sicherheits-ventil
	Gurtstraffer		Gasdruck-dämpfer		Kraftstofftank		



Golf 6 Plus (BiFuel, ab 2009)



Golf 6 Plus

(BiFuel, ab 2009)



Hinweise zur Flüssiggasanlage

Der Gastank der Flüssiggasanlage des Golf 6 Plus BiFuel hat keine mechanische, manuelle Absperrmöglichkeit!



Der Flüssiggastank in der Reserveradmulde

1. Flüssiggastank lokalisieren

- Er ist unter dem Ladeboden in der Reserveradmulde montiert.
- Der Gastank verfügt nur über ein elektromagnetisches Absperrventil, das stromlos geschlossen ist.









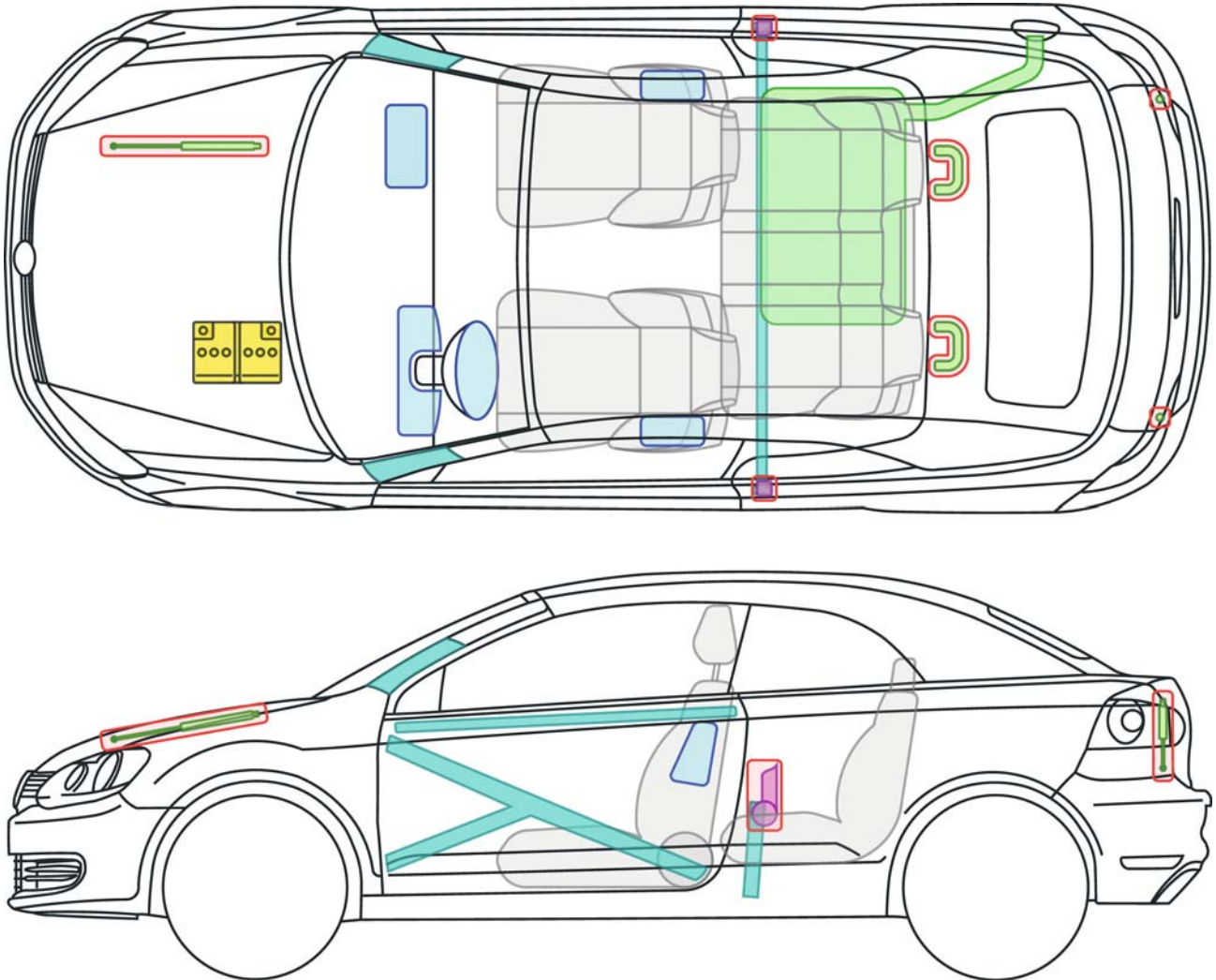

Golf 6

(Cabriolet, ab 2011)

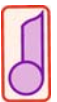

Legende

	Airbag		Karosserie-Verstärkung		Steuergerät
			Überrollschutz		12 V-Batterie
	Gurtstraffer		Gasdruckdämpfer		Kraftstofftank







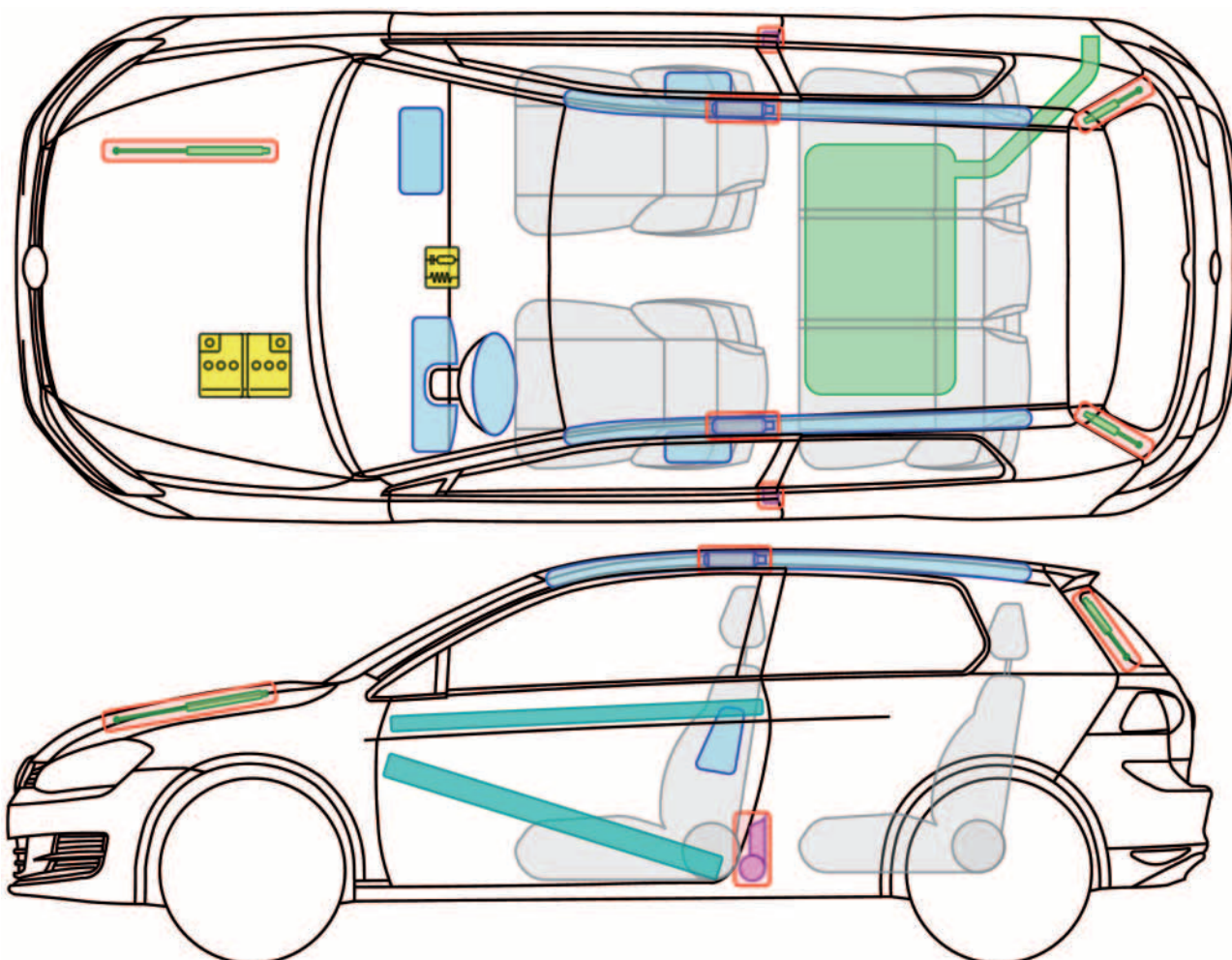



Golf 7

(3-Türer, ab 2012)



Legende

	Airbag		Karosserie-Verstärkung		Steuergerät
	Gas-generator				12 V-Batterie
	Gurtstraffer		Gasdruck-dämpfer		Kraftstofftank



Golf 7 (3-Türer, ab 2012)







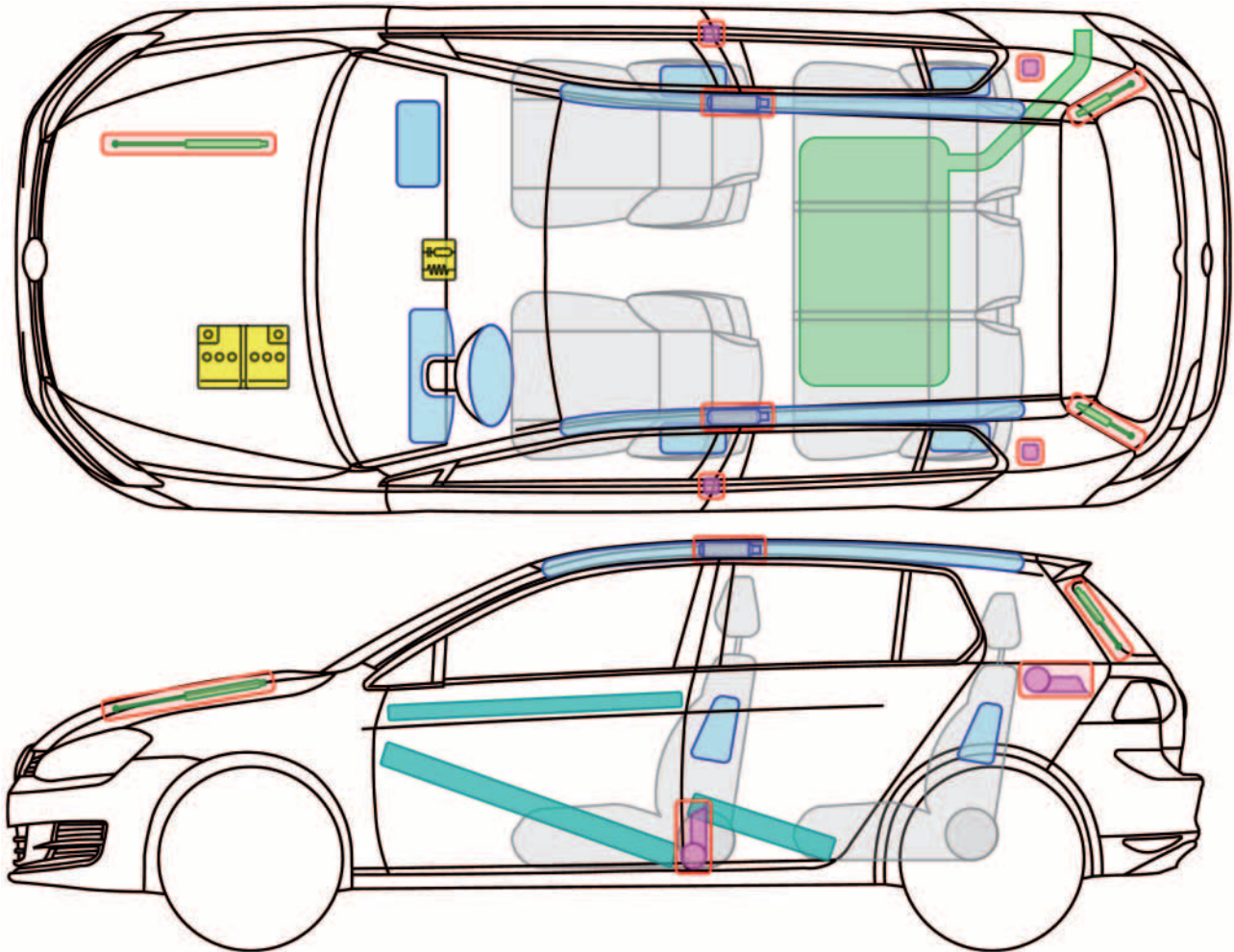



Golf 7

(5-Türer, ab 2012)



Legende

	Airbag		Karosserie-Verstärkung		Steuergerät
	Gas-generator				12 V-Batterie
	Gurtstraffer		Gasdruck-dämpfer		Kraftstofftank







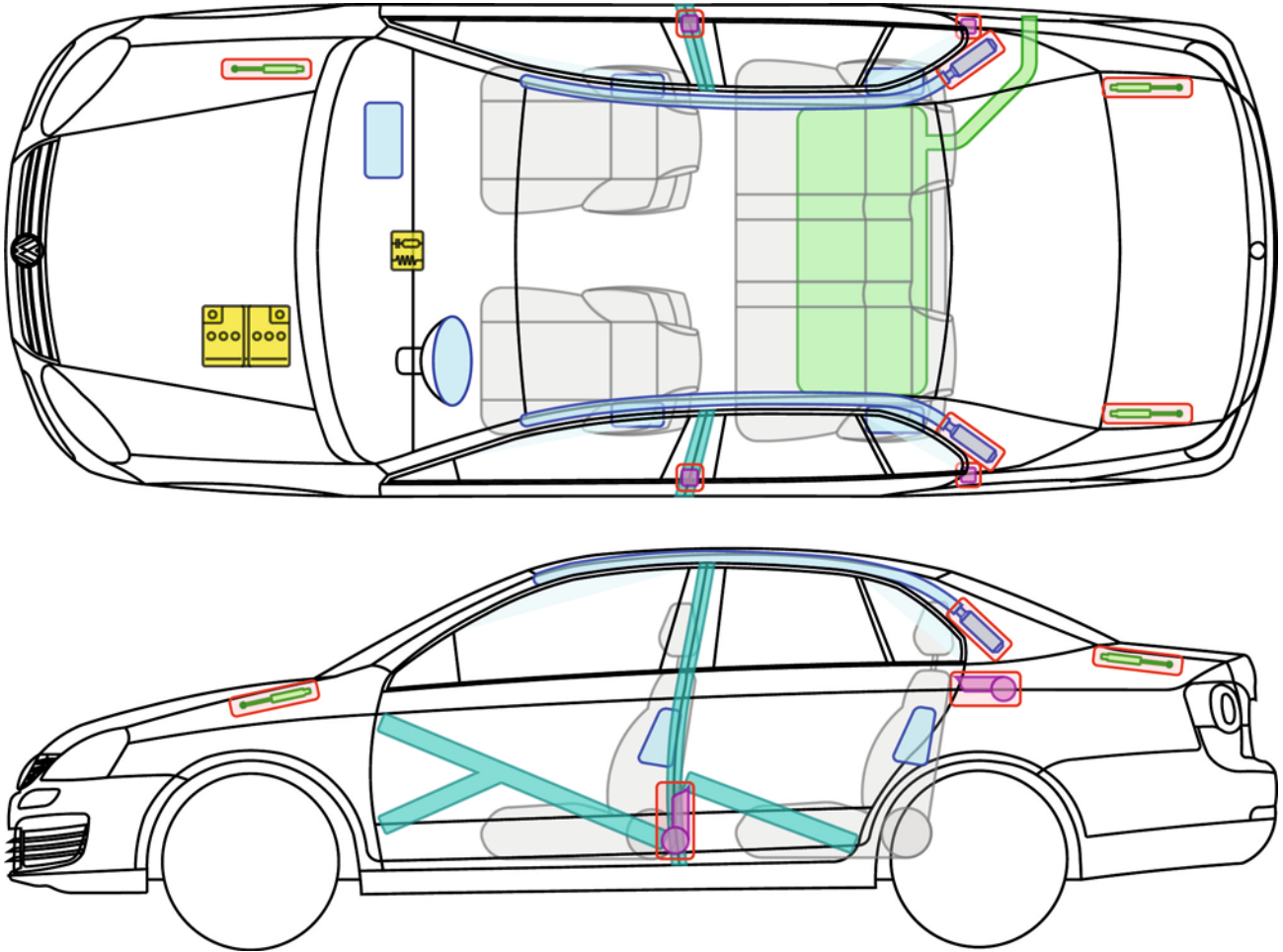



Jetta

(2005 - 2010)



Legende

	Airbag		Karosserie-Verstärkung		Steuergerät
	Gas-generator				12 V-Batterie
	Gurtstraffer		Gasdruck-dämpfer		Kraftstofftank







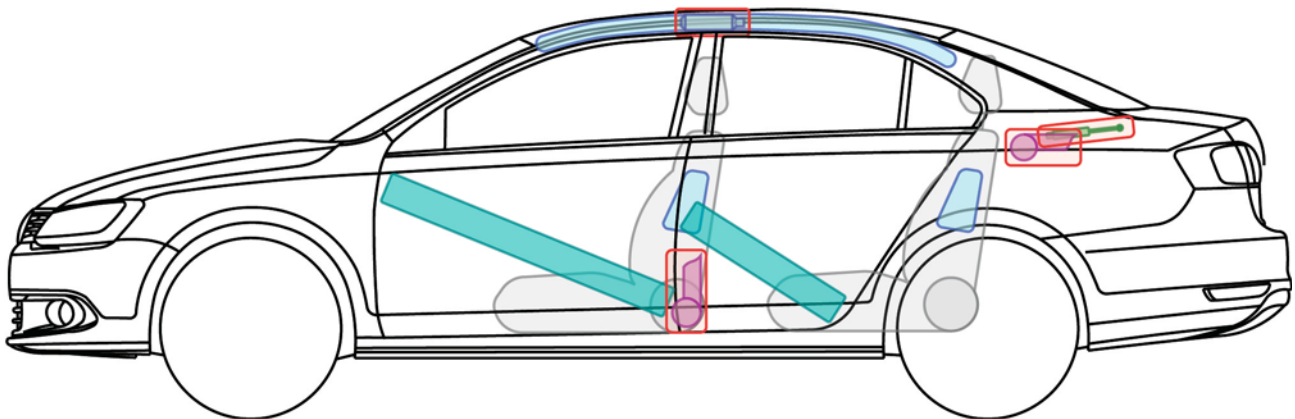
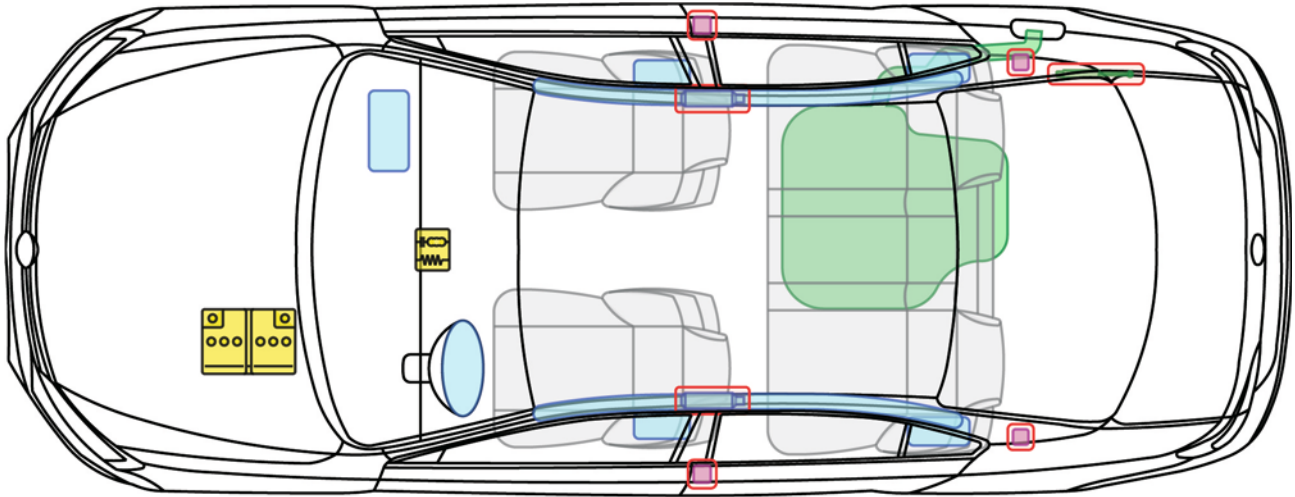



Jetta

(ab 2010)



Legende

	Airbag		Karosserie-Verstärkung		Steuergerät
	Gas-generator				12 V-Batterie
	Gurtstraffer		Gasdruck-dämpfer		Kraftstofftank



Lupo



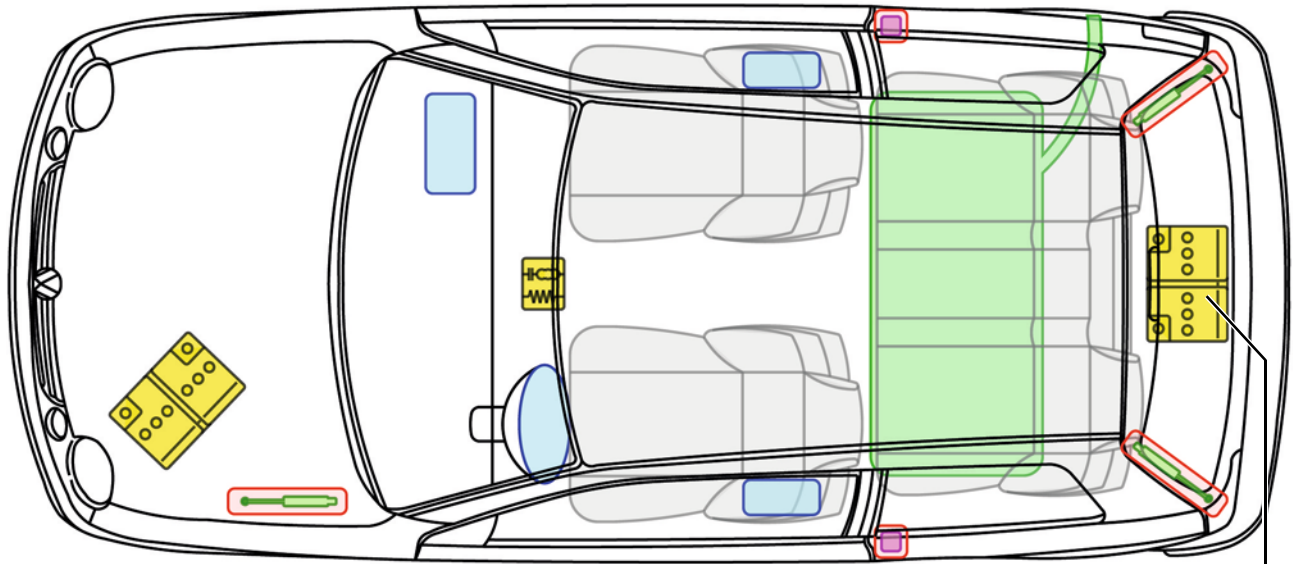

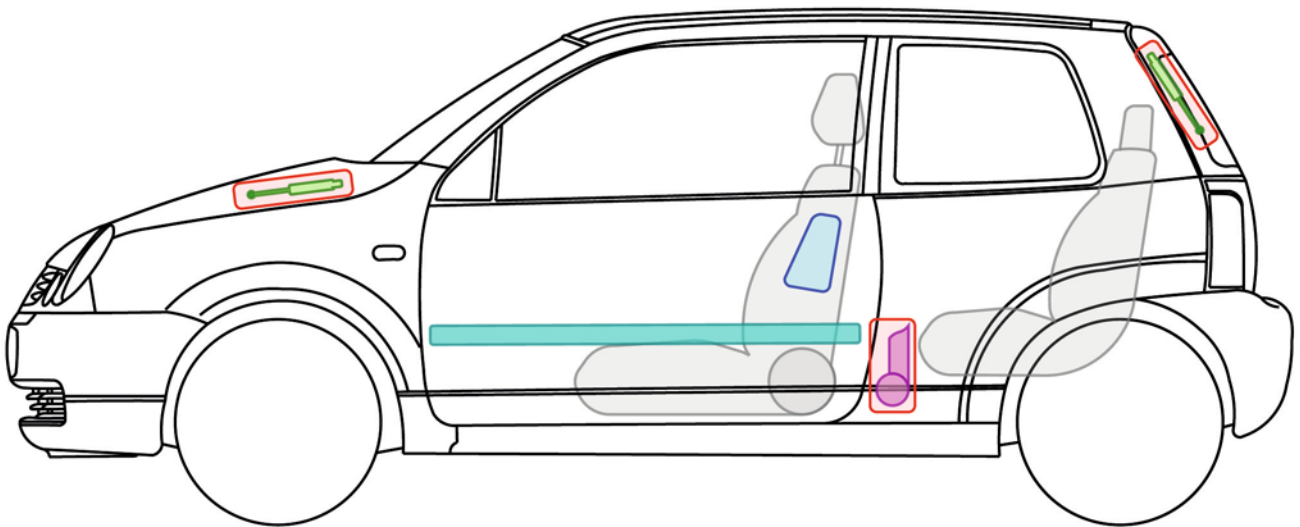

(1998 - 2005)



nur Lupo 3L und Lupo GTI



Legende

	Airbag		Karosserie-Verstärkung		Steuergerät
					12V-Batterie
	Gurtstraffer		Gasdruckdämpfer		Kraftstofftank







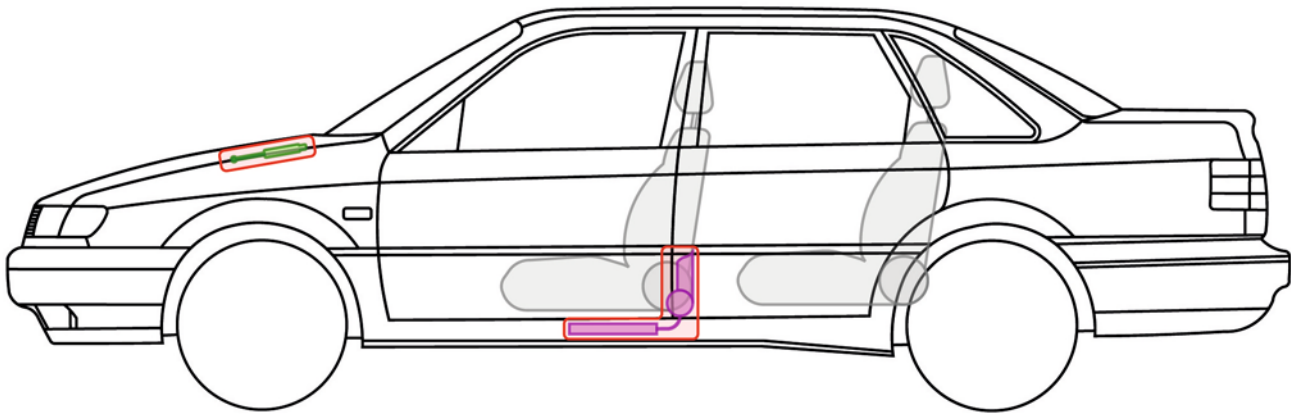
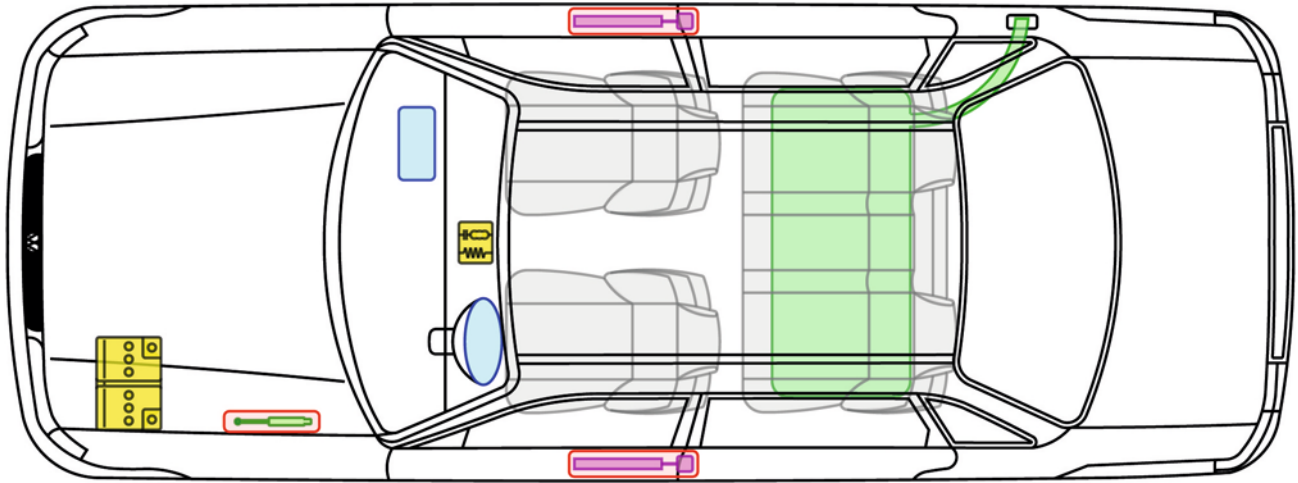

Passat B4

(Limousine, 1993 - 1996)



Legende

	Airbag		Steuergerät
			12 V-Batterie
	Gurtstraffer		Gasdruckdämpfer
			Kraftstofftank







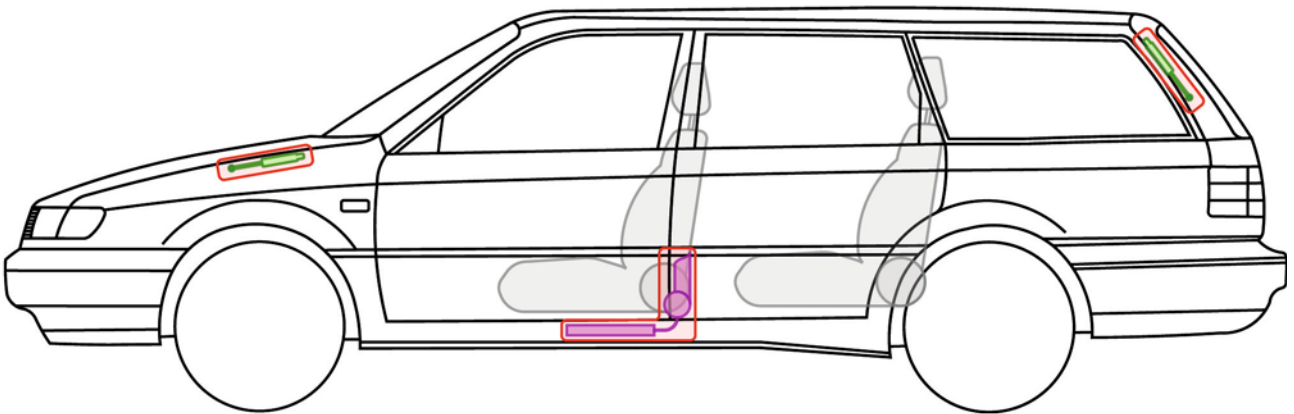
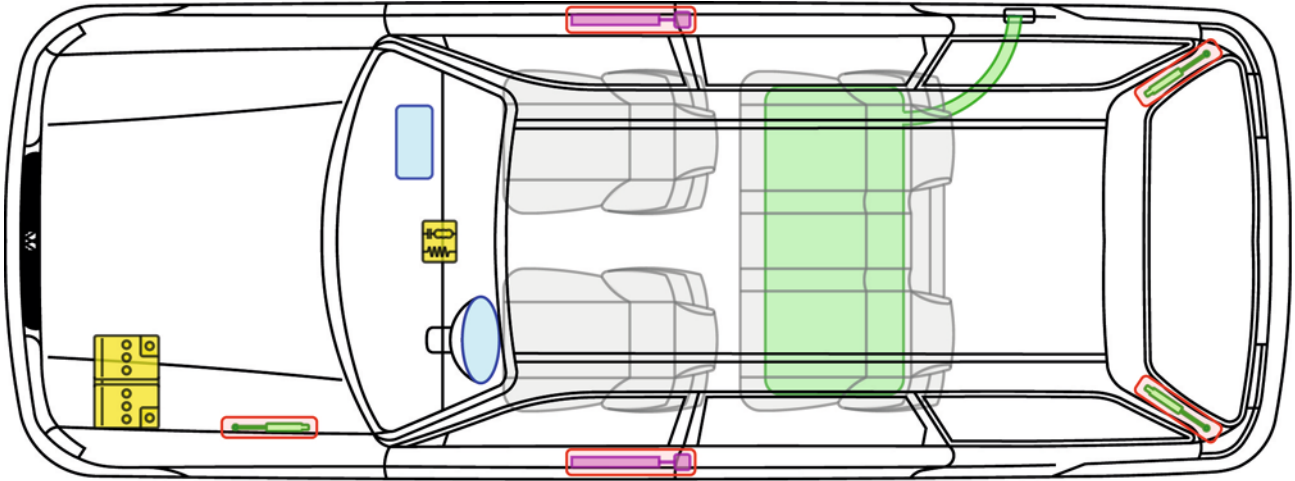

Passat B4

(Variant, 1993 - 1997)



Legende

	Airbag		Steuergerät
			12 V-Batterie
	Gurtstraffer		Kraftstofftank
		Gasdruckdämpfer	







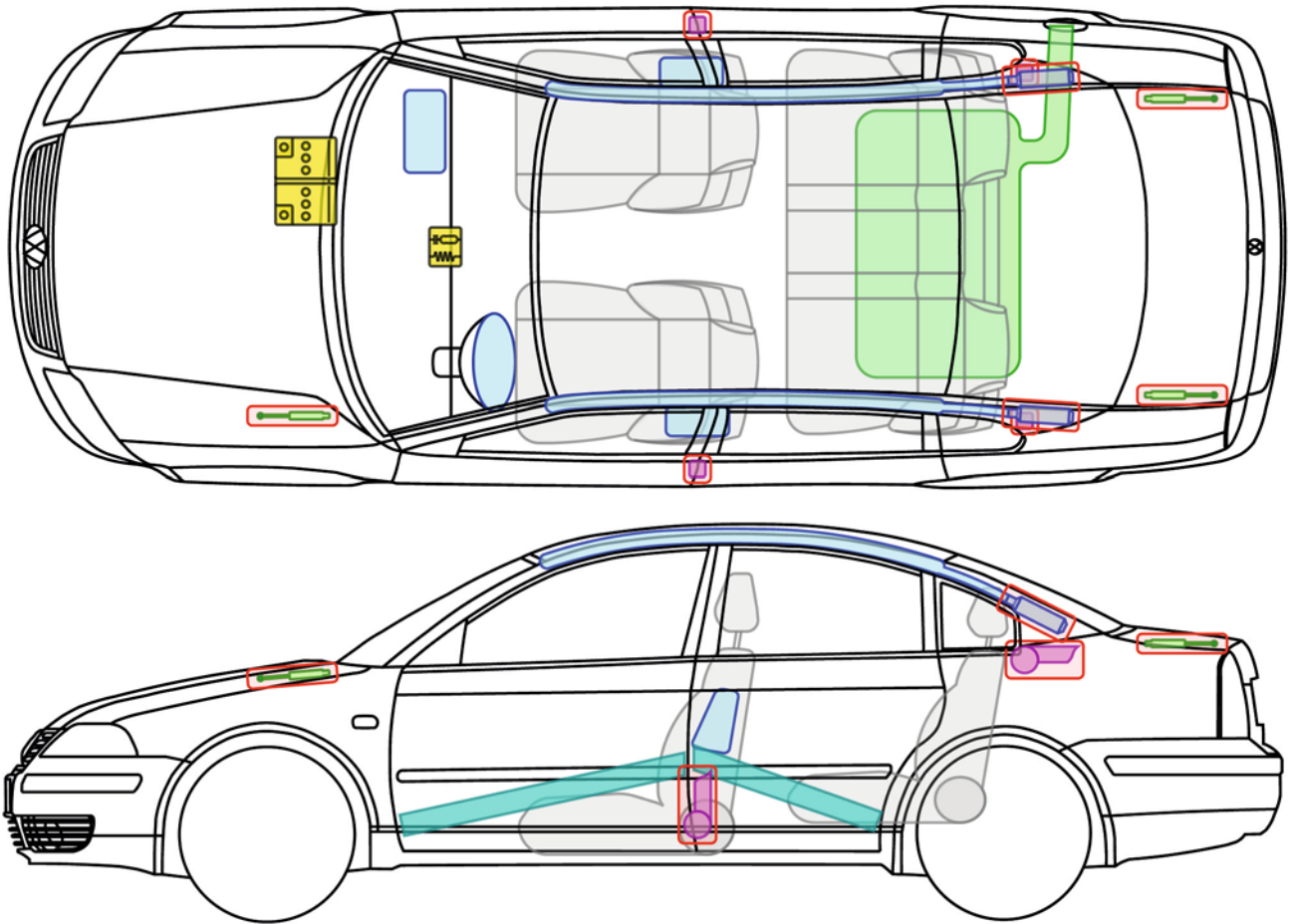



Passat B5

(Limousine, 1996 - 2005)



Legende

	Airbag		Karosserie-Verstärkung		Steuergerät	
	Gas-generator				12 V-Batterie	
	Gurtstraffer		Gasdruck-dämpfer		Kraftstofftank	







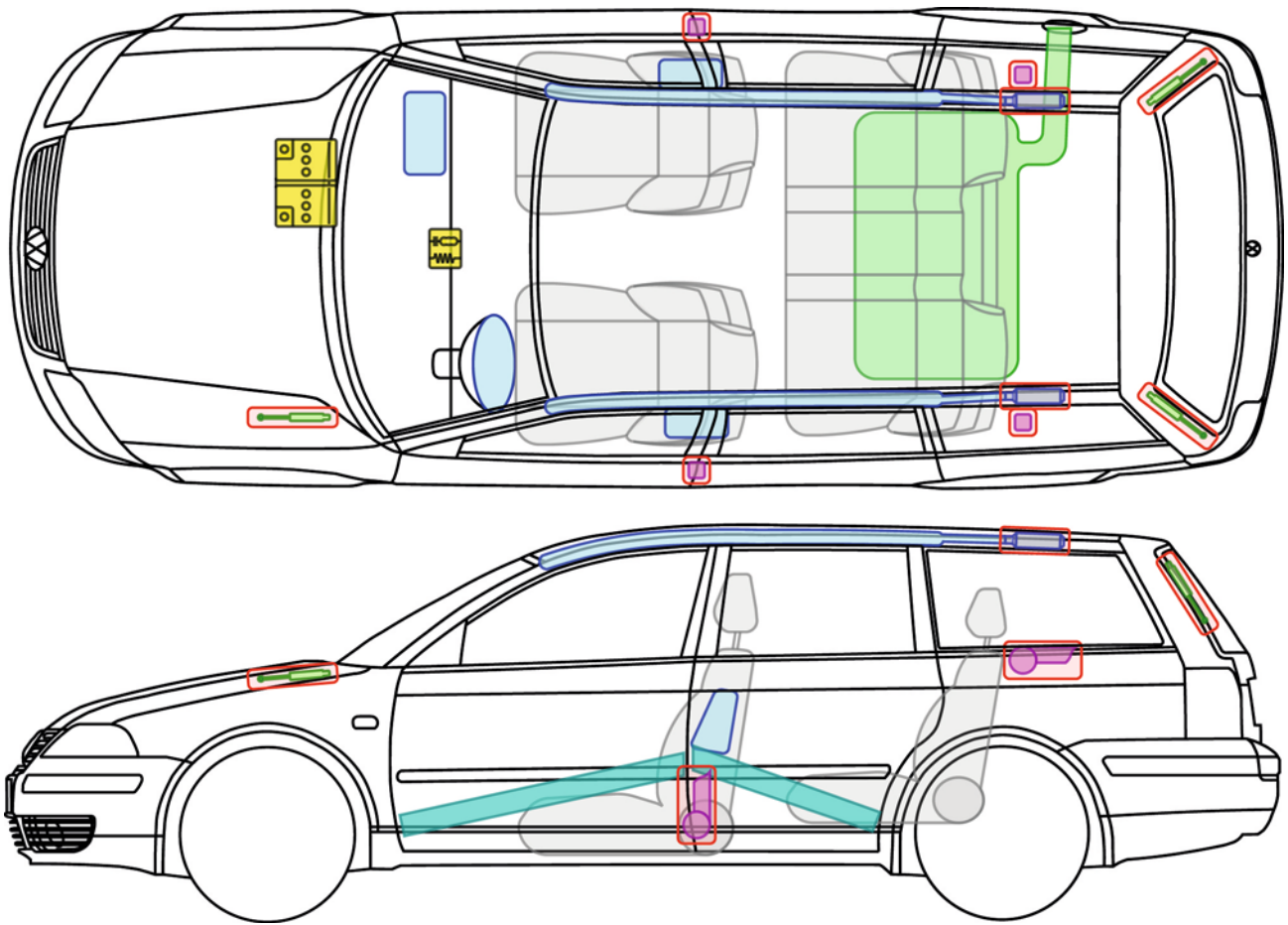



Passat B5

(Variant, 1997 - 2005)



Legende

	Airbag		Karosserie-Verstärkung		Steuergerät	
	Gas-generator				12V-Batterie	
	Gurtstraffer		Gasdruck-dämpfer		Kraftstofftank	



Passat B6



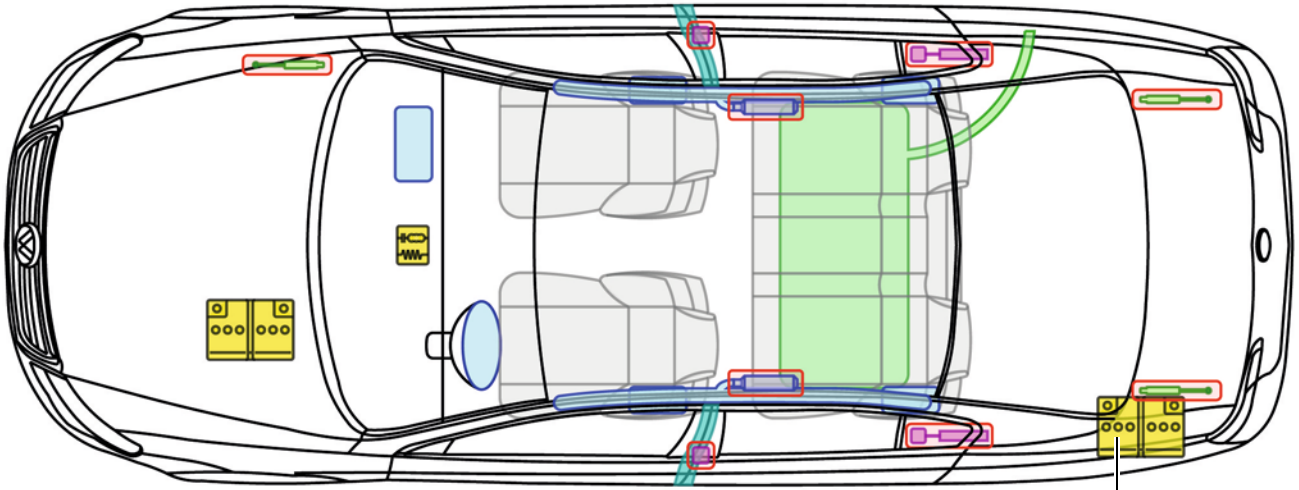



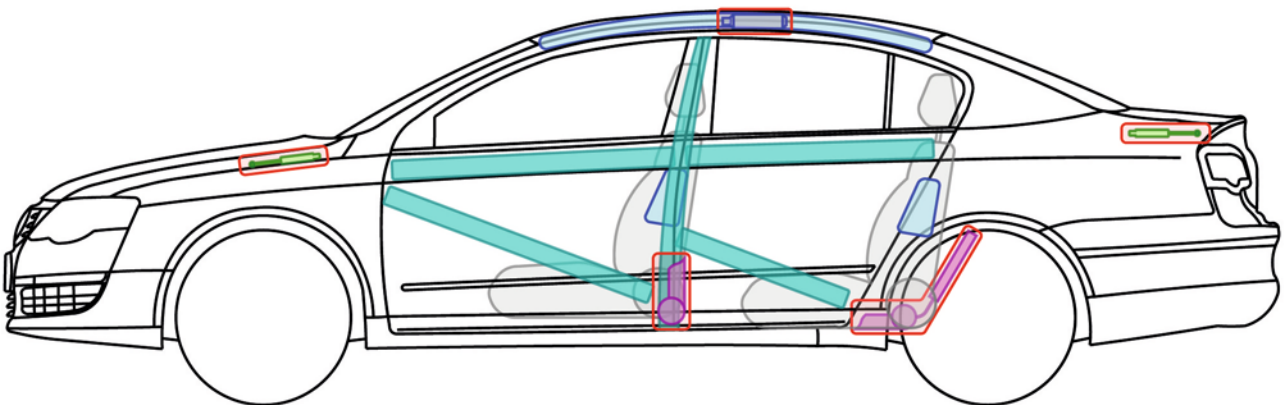

(Limousine, 2005 - 2010)



als 2. Batterie nur Passat R36 sonst ausstattungsabhängige Zusatzbatterie



Legende

	Airbag		Karosserie-Verstärkung		Steuergerät
	Gas-generator				12 V-Batterie
	Gurtstraffer		Gasdruck-dämpfer		Kraftstofftank
					Gurtstraffer



Passat B6

(Limousine, 2005 - 2010)



Fahrzeug deaktivieren

Batterie abklemmen (gilt nur bei Passat B6 R36)



1. Batterieabdeckung im Kofferraum entfernen

- Batterieabdeckung im Kofferraum auf der linken Fahrzeugseite lokalisieren
- Befestigungsschrauben lösen und Abdeckung abnehmen

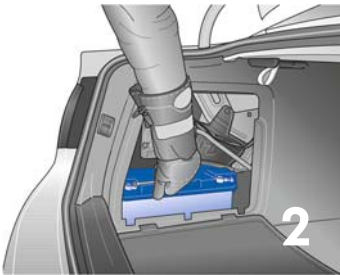

2. Masseanschluss (-) an der Batterie abklemmen



Passat B6



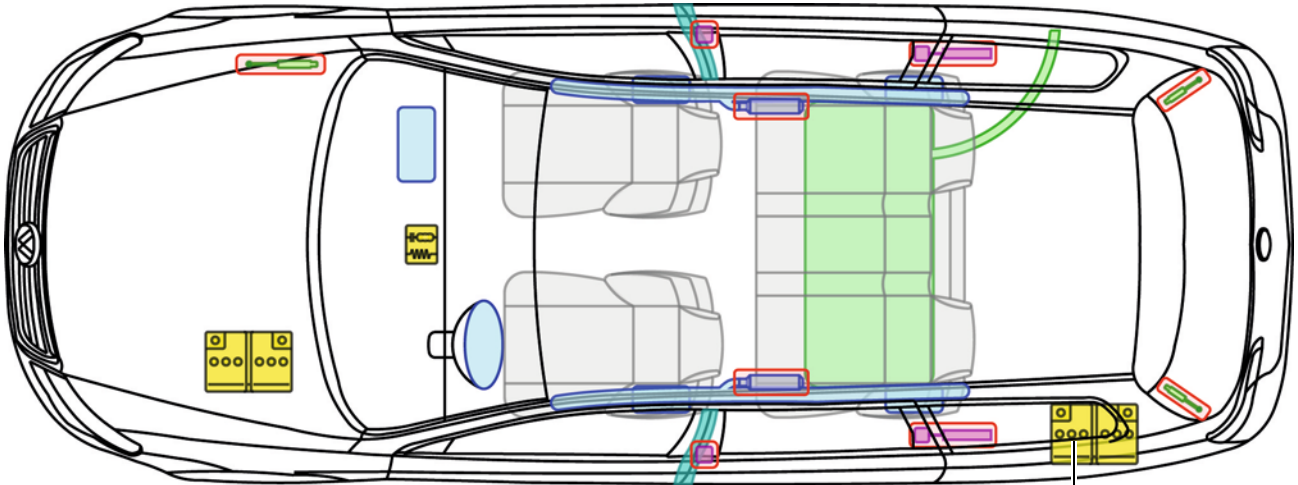



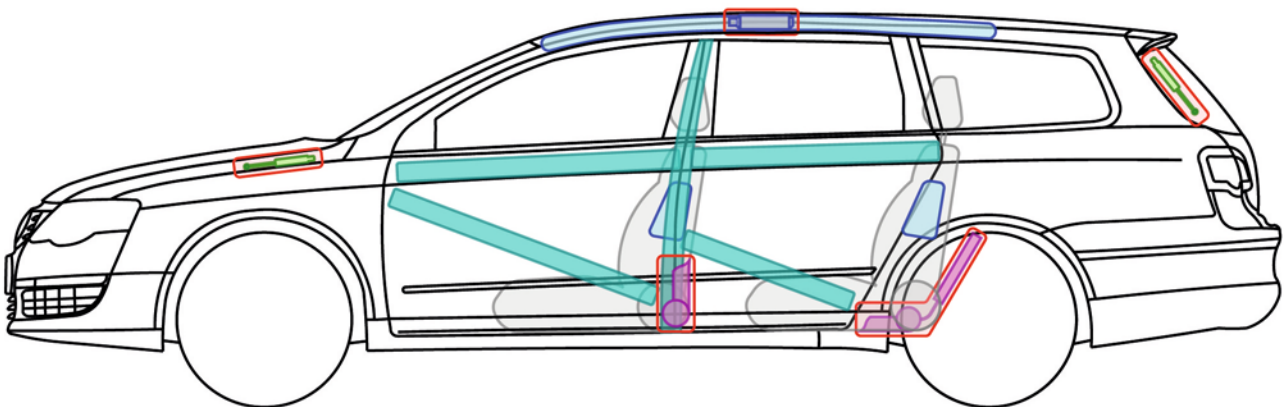

(Variant, ab 2005)



als 2. Batterie nur Passat R36 sonst ausstattungsabhängige Zusatzbatterie



Legende

	Airbag		Karosserie-Verstärkung		Steuergerät		
	Gas-generator				12V-Batterie		
	Gurtstraffer		Gasdruck-dämpfer		Kraftstofftank		Gurtstraffer



Passat B6

(Variant, ab 2005)



Fahrzeug deaktivieren

Batterie abklemmen (gilt nur bei Passat B6 R36)



1. Batterieabdeckung im Kofferraum entfernen

- Batterieabdeckung im Kofferraum auf der linken Fahrzeugseite lokalisieren
- Befestigungsschrauben lösen und Abdeckung abnehmen

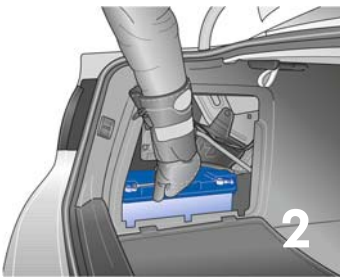

2. Masseanschluss (-) an der Batterie abklemmen



Passat B6

(Lim. EcoFuel, ab 2009)

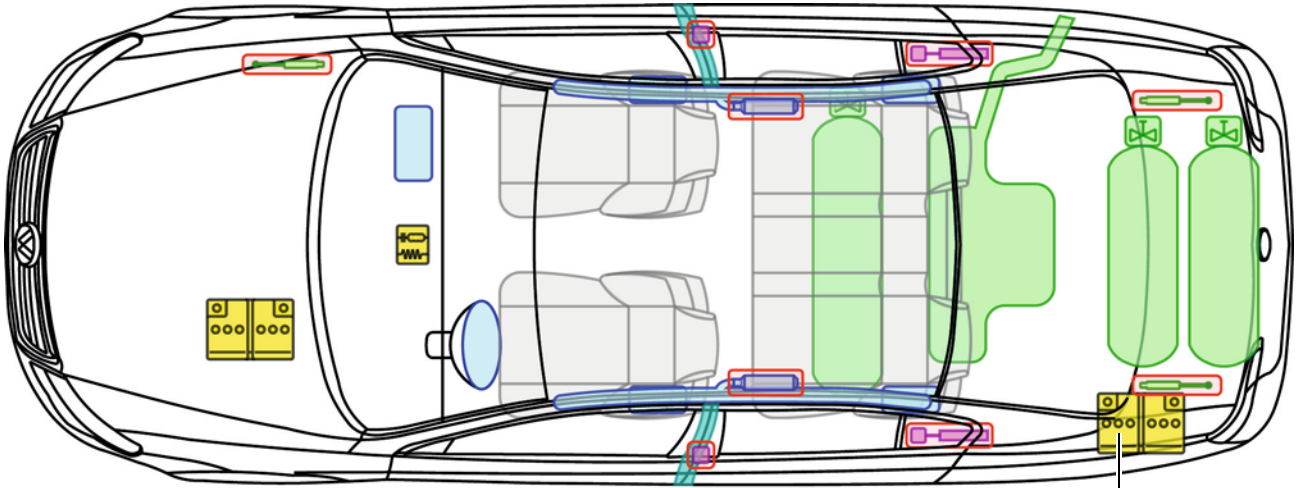







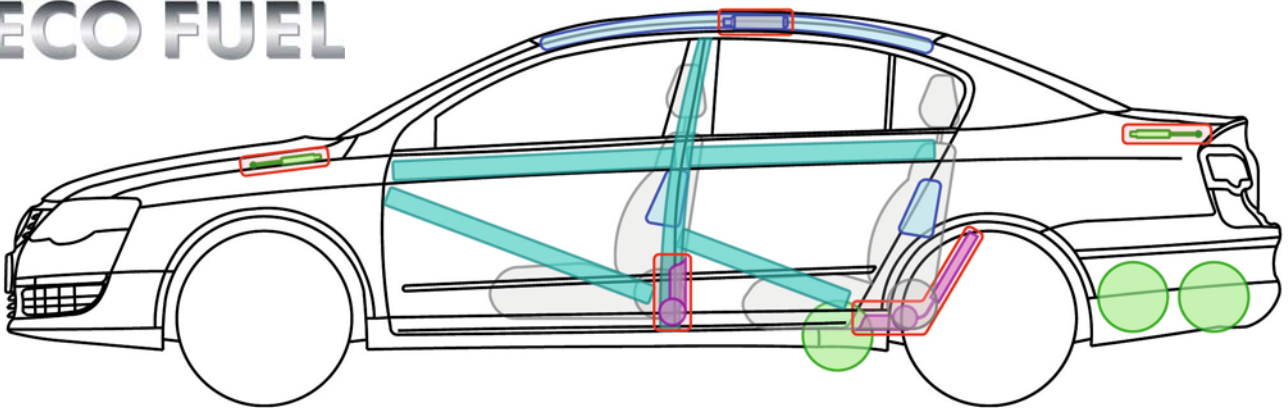

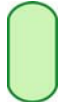

als 2. Batterie nur Passat R36 sonst ausstattungsabhängige Zusatzbatterie

Erdgasantrieb

ECO FUEL



Legende

	Airbag		Karosserie-Verstärkung		Steuergerät		Gastank
	Gas-generator				12V-Batterie		Sicherheits-ventil
	Gurtstraffer		Gasdruck-dämpfer		Kraftstofftank		Gurtstraffer

P

Passat B6 (Limousine EcoFuel, ab 2009)



Passat B6

(Lim. EcoFuel, ab 2009)



Hinweise zur Erdgasanlage

Gastanks manuell absperren (bei Gasgeruch bzw. Austritt von Erdgas)

1. Zugang zu den Erdgastanks

- Der Zugang zu den Tanks erfolgt vom Unterboden aus.
- Die Gastanks sind durch eine Kunststoffabdeckung verkleidet. Um an die Erdgastanks zu gelangen, muss diese Abdeckung mit geeigneten Mitteln entfernt werden, ohne die darunter liegenden Bauteile der Gasanlage zu beschädigen.

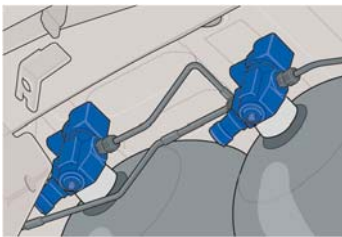

elektromagnetische Absperrventile an den Gastanks

2. Absperrhähne lokalisieren

- Jeder Gastank besitzt ein eigenes Flaschenventil mit einem manuellen Absperrhahn.
- Falls einsatzbedingt erforderlich muss jeder Gastank separat abgesperrt werden.

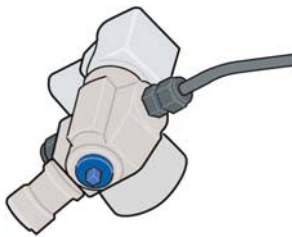

manueller Absperrhahn am Fuß des Flaschenventils.

3. Gastank von Hand schließen

- Falls einsatzbedingt erforderlich muss jeder Gastank separat abgesperrt werden.
- Mit einem 5er-Maul- bzw. Ringschlüssel lässt sich das manuelle Absperrventil am Vierkant durch Drehen im Uhrzeigersinn bis zum Anschlag des Ventils verschließen.



Passat B6

(Variant EcoFuel, ab 2009)

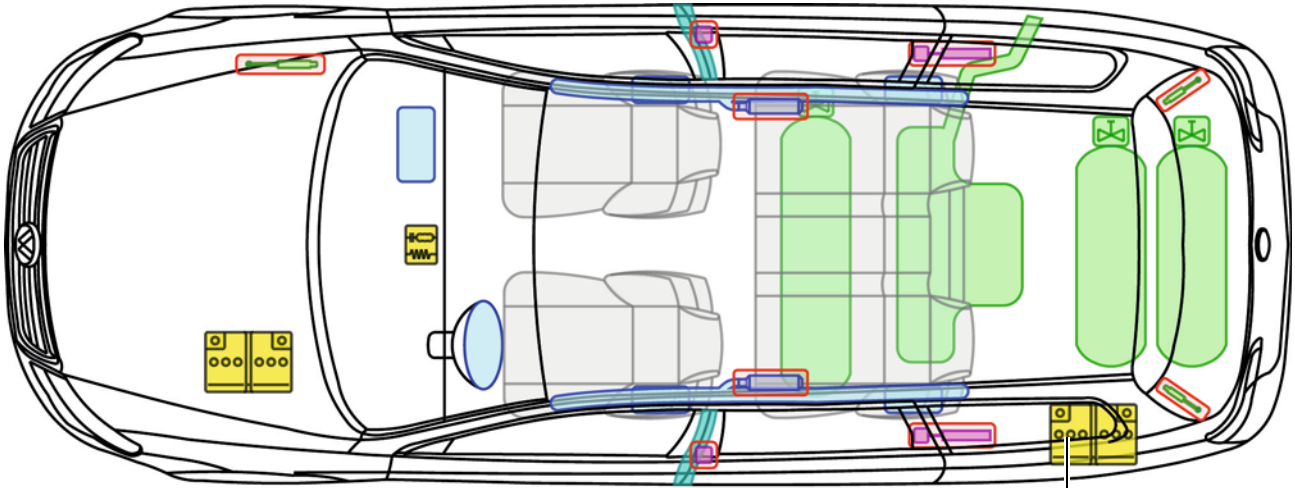







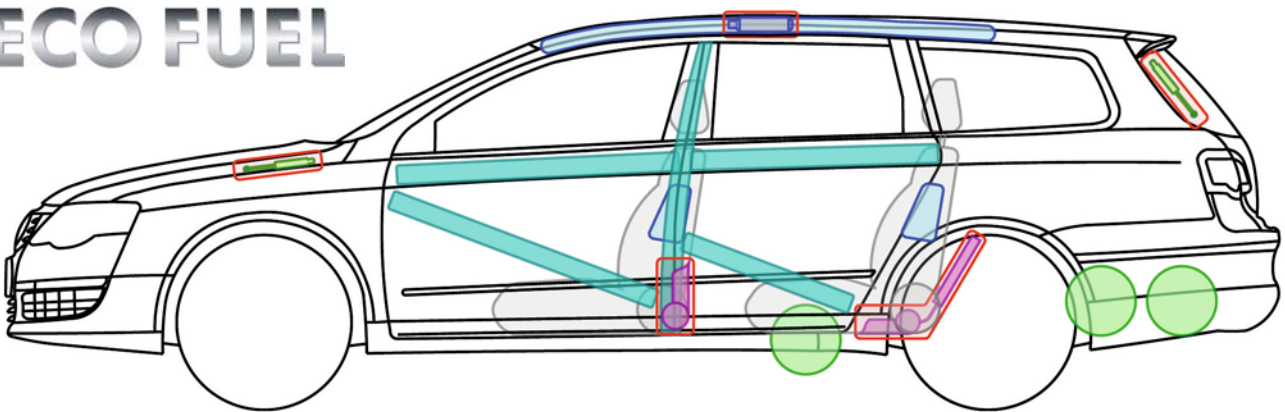

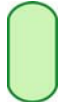

als 2. Batterie nur Passat R36 sonst ausstattungsabhängige Zusatzbatterie

Erdgasantrieb

ECO FUEL

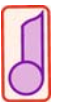

Legende

	Airbag		Karosserie-Verstärkung		Steuergerät		Gastank
	Gas-generator				12V-Batterie		Sicherheits-ventil
	Gurtstraffer		Gasdruck-dämpfer		Kraftstofftank		Gurtstraffer

P

Passat B6 (Variant EcoFuel, ab 2009)



Passat B6 (Variant EcoFuel, ab 2009)



Hinweise zur Erdgasanlage

Gastanks manuell absperren (bei Gasgeruch bzw. Austritt von Erdgas)

1. Zugang zu den Erdgastanks

- Der Zugang zu den Tanks erfolgt vom Unterboden aus.
- Die Gastanks sind durch eine Kunststoffabdeckung verkleidet. Um an die Erdgastanks zu gelangen, muss diese Abdeckung mit geeigneten Mitteln entfernt werden, ohne die darunter liegenden Bauteile der Gasanlage zu beschädigen.

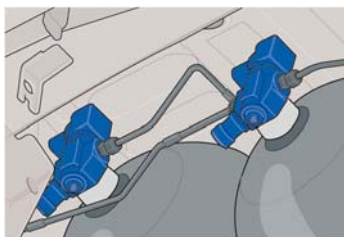

elektromagnetische Absperrventile an den Gastanks

2. Absperrhähne lokalisieren

- Jeder Gastank besitzt ein eigenes Flaschenventil mit einem manuellen Absperrhahn.
- Falls einsatzbedingt erforderlich muss jeder Gastank separat abgesperrt werden.



manueller Absperrhahn am Fuß des Flaschenventils.

3. Gastank von Hand schließen

- Falls einsatzbedingt erforderlich muss jeder Gastank separat abgesperrt werden.
- Mit einem 5er-Maul- bzw. Ringschlüssel lässt sich das manuelle Absperrventil am Vierkant durch Drehen im Uhrzeigersinn bis zum Anschlag des Ventils verschließen.



Passat B7



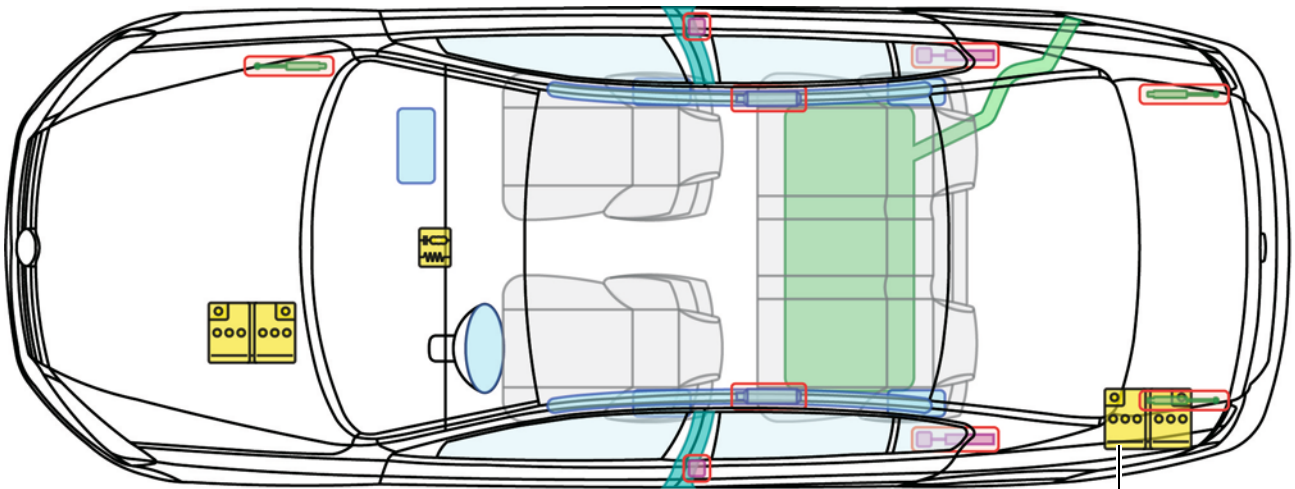



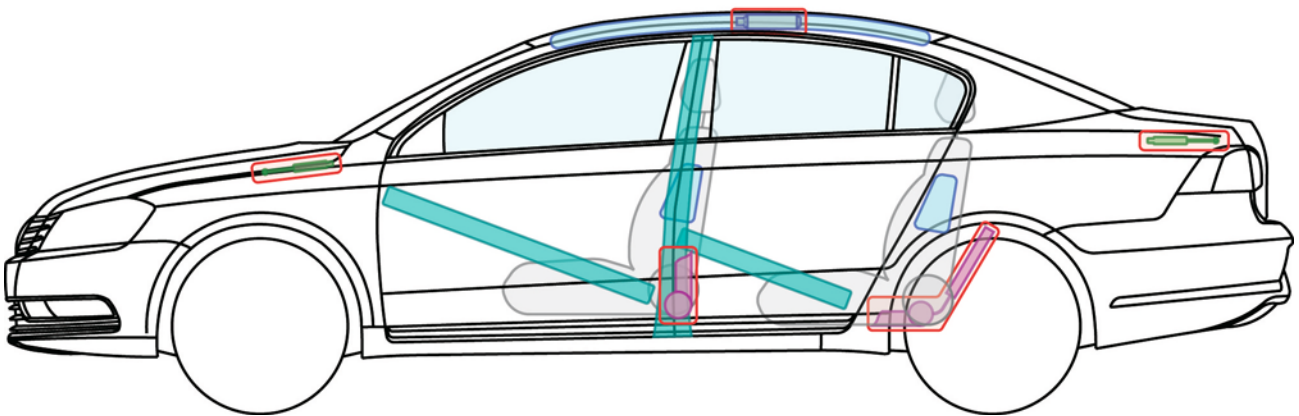

(Limousine, ab 2010)



als 2. Batterie nur Passat R36 sonst ausstattungsabhängige Zusatzbatterie



Legende

	Airbag		Karosserie-Verstärkung		Steuergerät		
	Gas-generator				12V-Batterie		
	Gurtstraffer		Gasdruck-dämpfer		Kraftstofftank		Gurtstraffer



Passat B7

(Limousine, ab 2010)



Fahrzeug deaktivieren

Batterie abklemmen (gilt nur bei Passat B7 R36)



1. Batterieabdeckung im Kofferraum entfernen

- Batterieabdeckung im Kofferraum auf der linken Fahrzeugseite lokalisieren
- Befestigungsschrauben lösen und Abdeckung abnehmen

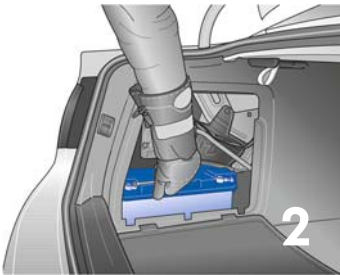

2. Masseanschluss (-) an der Batterie abklemmen



Passat B7



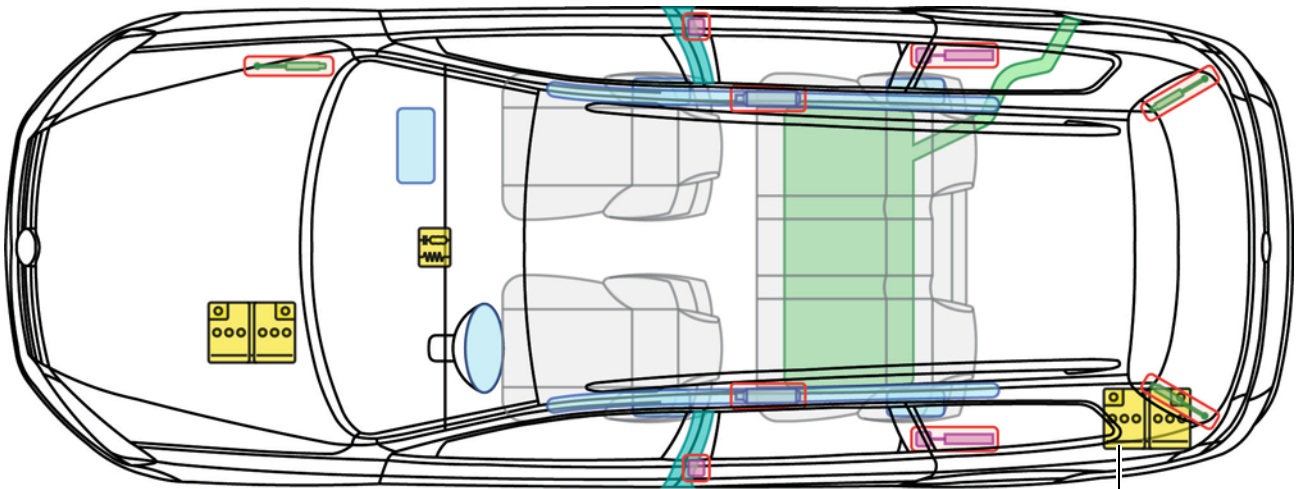



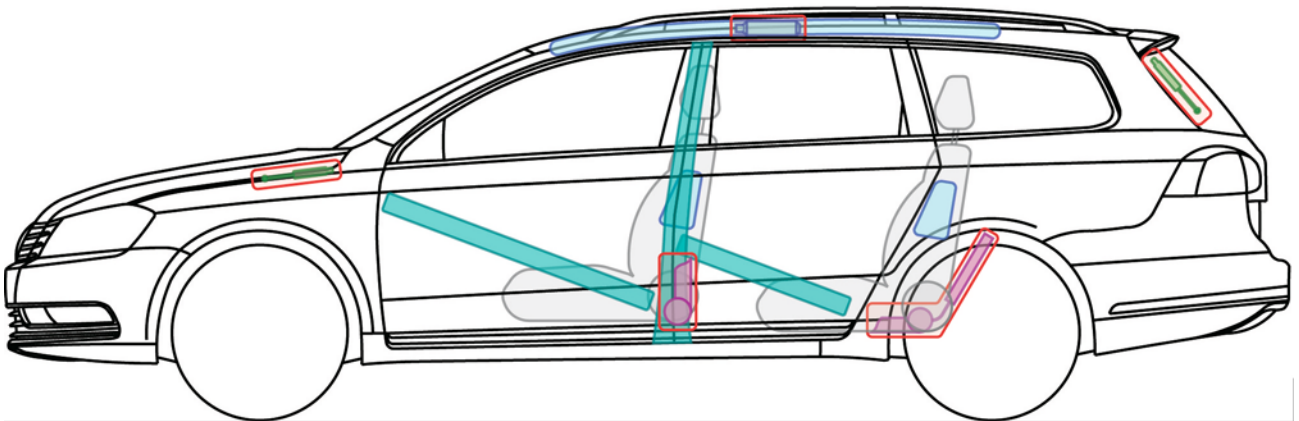

(Variant, ab 2010)



als 2. Batterie nur Passat R36 sonst ausstattungsabhängige Zusatzbatterie



Legende

	Airbag		Karosserie-Verstärkung		Steuergerät
	Gas-generator				12V-Batterie
	Gurtstraffer		Gasdruck-dämpfer		Kraftstofftank
					Gurtstraffer



Passat B7 (Variant, ab 2010)



Fahrzeug deaktivieren

Batterie abklemmen (gilt nur bei Passat B7 R36)



1. Batterieabdeckung im Kofferraum entfernen

- Batterieabdeckung im Kofferraum auf der linken Fahrzeugseite lokalisieren
- Befestigungsschrauben lösen und Abdeckung abnehmen



2. Masseanschluss (-) an der Batterie abklemmen



Passat B7

(Lim. EcoFuel, ab 2010)

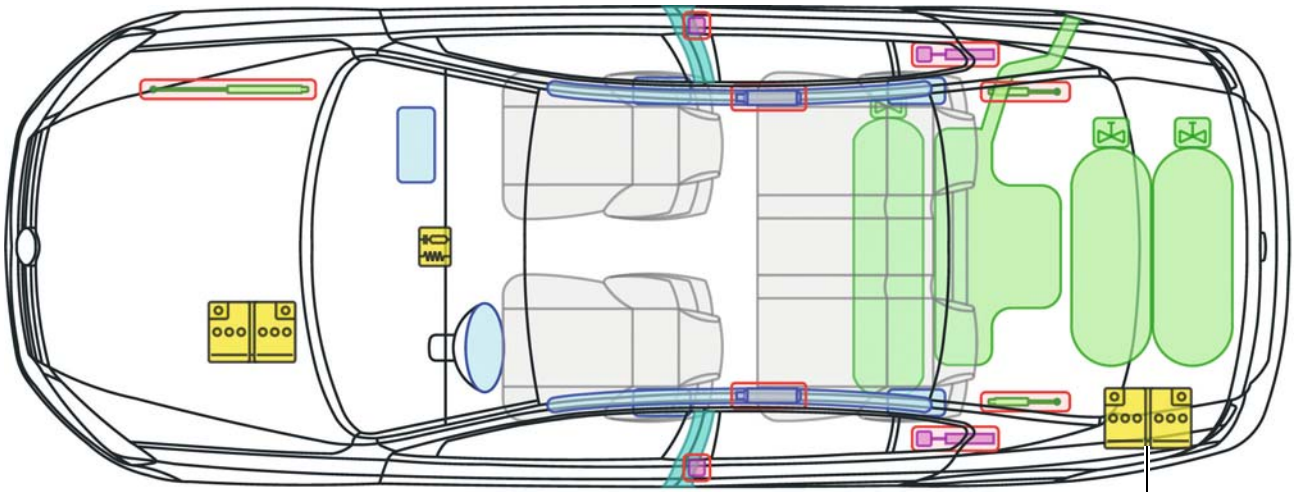







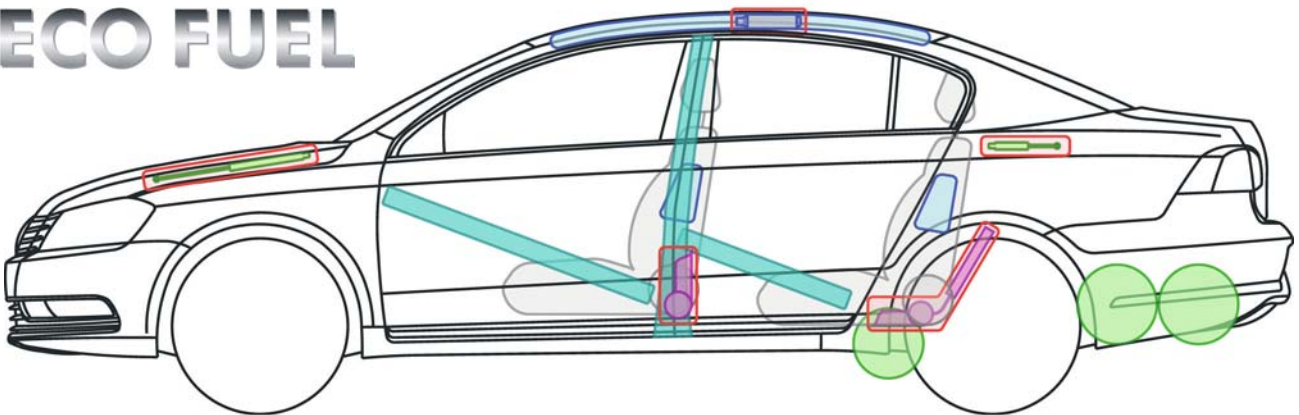

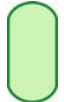

als 2. Batterie nur Passat R36 sonst ausstattungsabhängige Zusatzbatterie

Erdgasantrieb

ECO FUEL



Legende

	Airbag		Karosserie-Verstärkung		Steuergerät		Gastank
	Gas-generator				12 V-Batterie		Sicherheits-ventil
	Gurtstraffer		Gasdruck-dämpfer		Kraftstofftank		Gurtstraffer



Hinweise zur Erdgasanlage

Gastanks manuell absperren (bei Gasgeruch bzw. Austritt von Erdgas)

1. Zugang zu den Erdgastanks

- Der Zugang zu den Tanks erfolgt vom Unterboden aus.
- Die Gastanks sind durch eine Kunststoffabdeckung verkleidet. Um an die Erdgastanks zu gelangen, muss diese Abdeckung mit geeigneten Mitteln entfernt werden, ohne die darunter liegenden Bauteile der Gasanlage zu beschädigen.

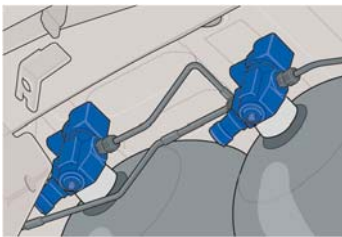

elektromagnetische Absperrventile an den Gastanks

2. Absperrhähne lokalisieren

- Jeder Gastank besitzt ein eigenes Flaschenventil mit einem manuellen Absperrhahn.
- Falls einsatzbedingt erforderlich muss jeder Gastank separat abgesperrt werden.

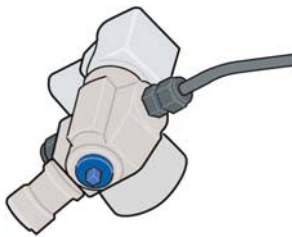

manueller Absperrhahn am Fuß des Flaschenventils.

3. Gastank von Hand schließen

- Falls einsatzbedingt erforderlich muss jeder Gastank separat abgesperrt werden.
- Mit einem 5er-Maul- bzw. Ringschlüssel lässt sich das manuelle Absperrventil am Vierkant durch Drehen im Uhrzeigersinn bis zum Anschlag des Ventils verschließen.



Passat B7

(Variant EcoFuel, ab 2010)

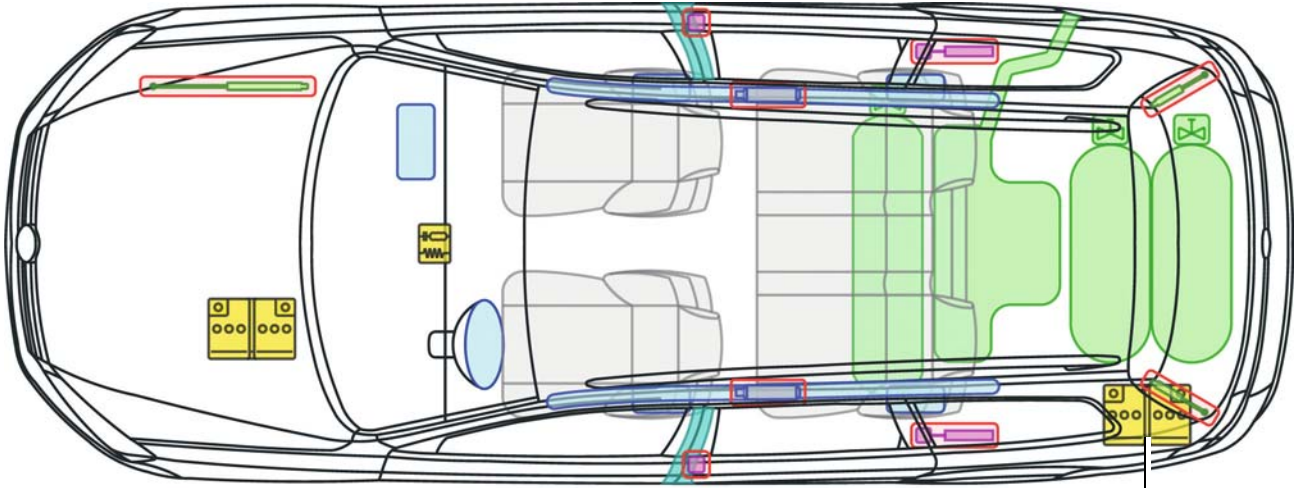







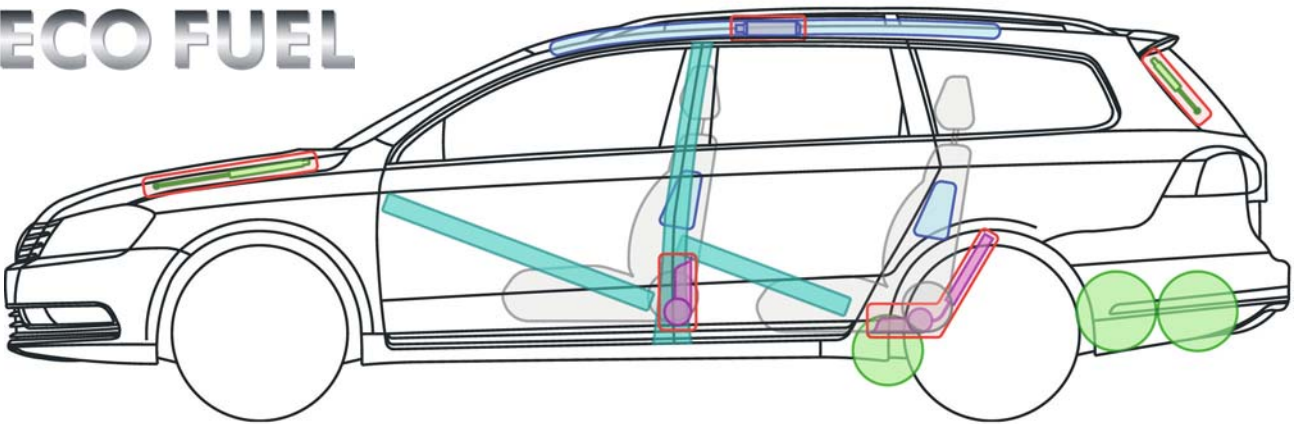

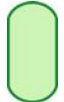

als 2. Batterie nur Passat R36 sonst ausstattungsabhängige Zusatzbatterie

Erdgasantrieb

ECO FUEL



Legende

	Airbag		Karosserie-Verstärkung		Steuergerät		Gastank
	Gas-generator				12V-Batterie		Sicherheitsventil
	Gurtstraffer		Gasdruck-dämpfer		Kraftstofftank		Gurtstraffer



Hinweise zur Erdgasanlage

Gastanks manuell absperren (bei Gasgeruch bzw. Austritt von Erdgas)

1. Zugang zu den Erdgastanks

- Der Zugang zu den Tanks erfolgt vom Unterboden aus.
- Die Gastanks sind durch eine Kunststoffabdeckung verkleidet. Um an die Erdgastanks zu gelangen, muss diese Abdeckung mit geeigneten Mitteln entfernt werden, ohne die darunter liegenden Bauteile der Gasanlage zu beschädigen.

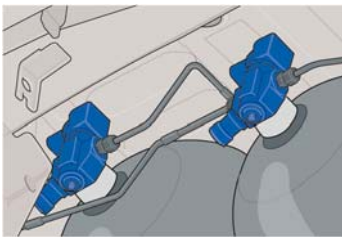

elektromagnetische Absperrventile an den Gastanks

2. Absperrhähne lokalisieren

- Jeder Gastank besitzt ein eigenes Flaschenventil mit einem manuellen Absperrhahn.
- Falls einsatzbedingt erforderlich muss jeder Gastank separat abgesperrt werden.

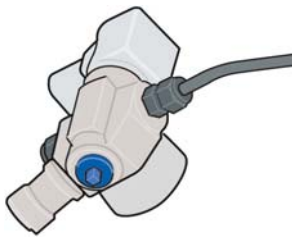

manueller Absperrhahn am Fuß des Flaschenventils.

3. Gastank von Hand schließen







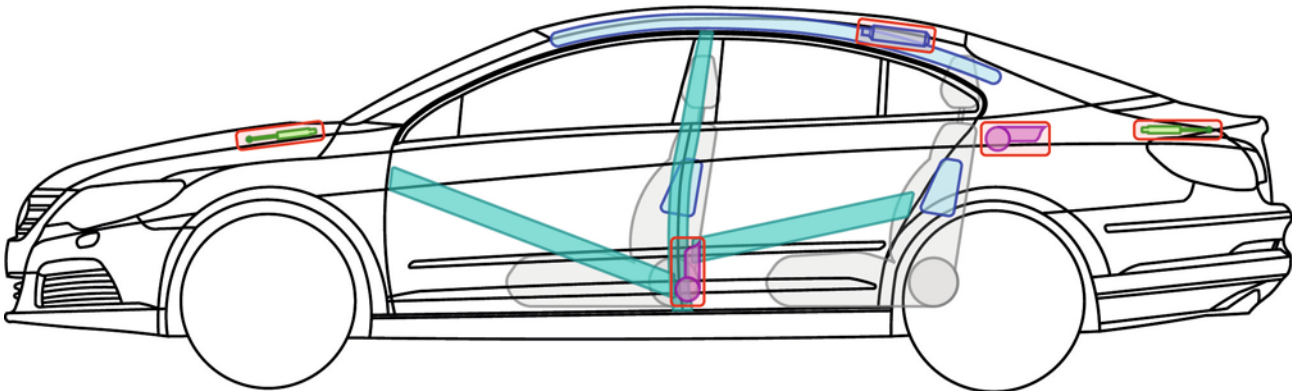
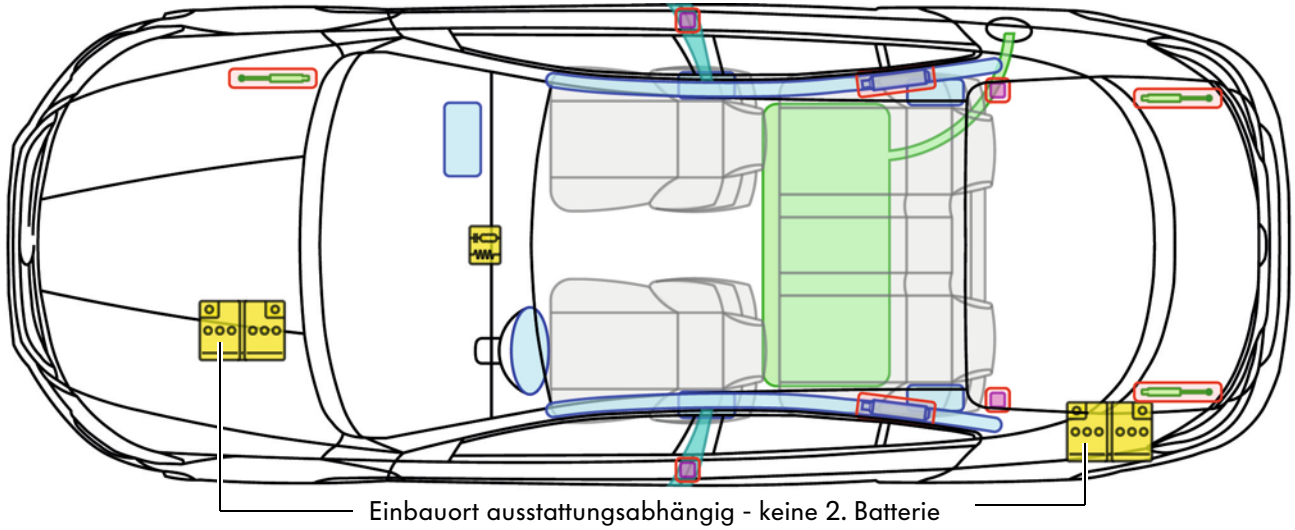

- Falls einsatzbedingt erforderlich muss jeder Gastank separat abgesperrt werden.
- Mit einem 5er-Maul- bzw. Ringschlüssel lässt sich das manuelle Absperrventil am Vierkant durch Drehen im Uhrzeigersinn bis zum Anschlag des Ventils verschließen.



Passat CC (ab 2008)



Legende

	Airbag		Karosserie-Verstärkung		Steuergerät	
	Gas-generator				12V-Batterie	
	Gurtstraffer		Gasdruckdämpfer		Kraftstofftank	



Fahrzeug deaktivieren

Batterie abklemmen (bei Einbauort Kofferraum)



1. Batterieabdeckung im Kofferraum entfernen

- Batterieabdeckung im Kofferraum auf der linken Fahrzeugseite lokalisieren
- Befestigungsschrauben lösen und Abdeckung abnehmen



2. Masseanschluss (-) an der Batterie abklemmen



Phaeton



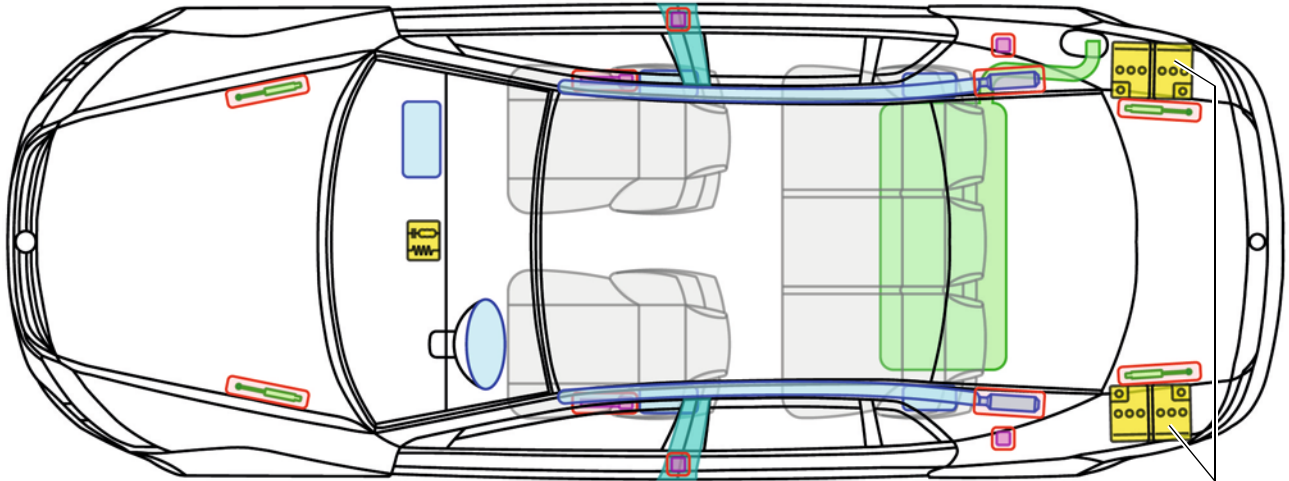

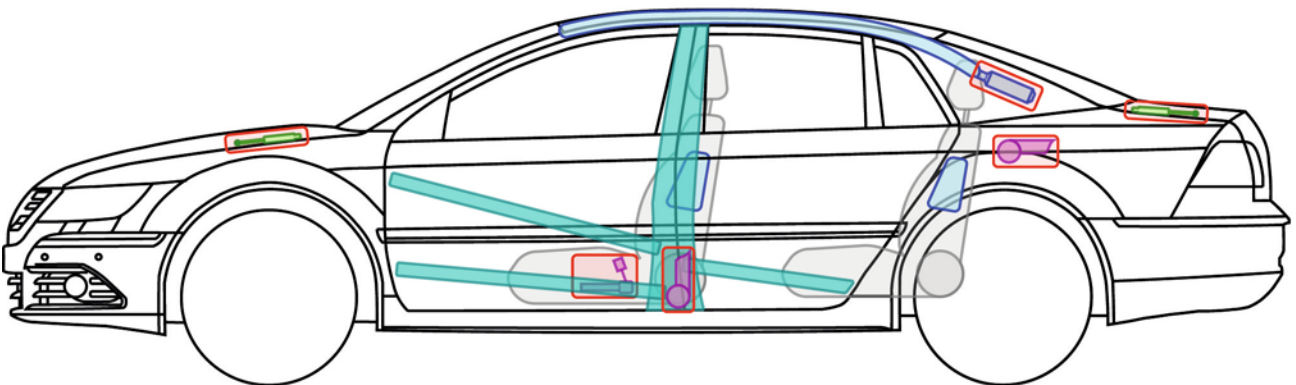

(ab 2002)



in jeder Ausstattung 2 Batterien im Kofferraum links und rechts.

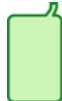
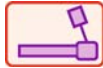

Legende

	Airbag		Karosserie-Verstärkung		Steuergerät
	Gas-generator				12 V-Batterie
	Gurtstraffer		Gasdruck-dämpfer		Kraftstofftank
					Beckengurt-straffer



Fahrzeug deaktivieren

Batterien abklemmen



1. Batterieabdeckungen im Kofferraum entfernen

- Batterieabdeckung im Kofferraum auf der linken und der rechten Fahrzeugseite lokalisieren
- Befestigungsschrauben lösen und beide Abdeckungen abnehmen



2. Masseanschluss (-) an beiden Batterien abklemmen







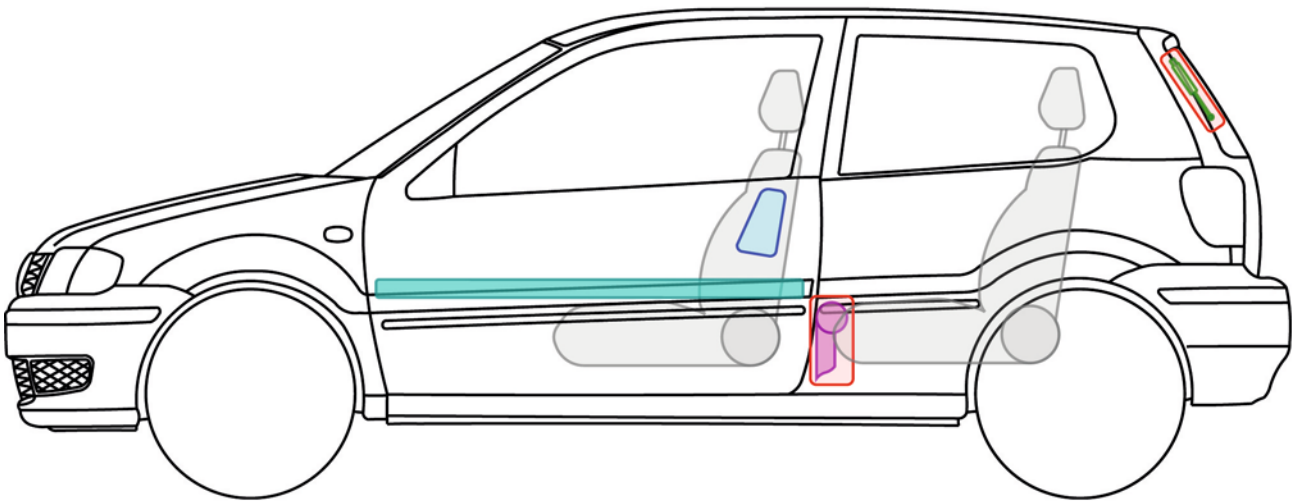
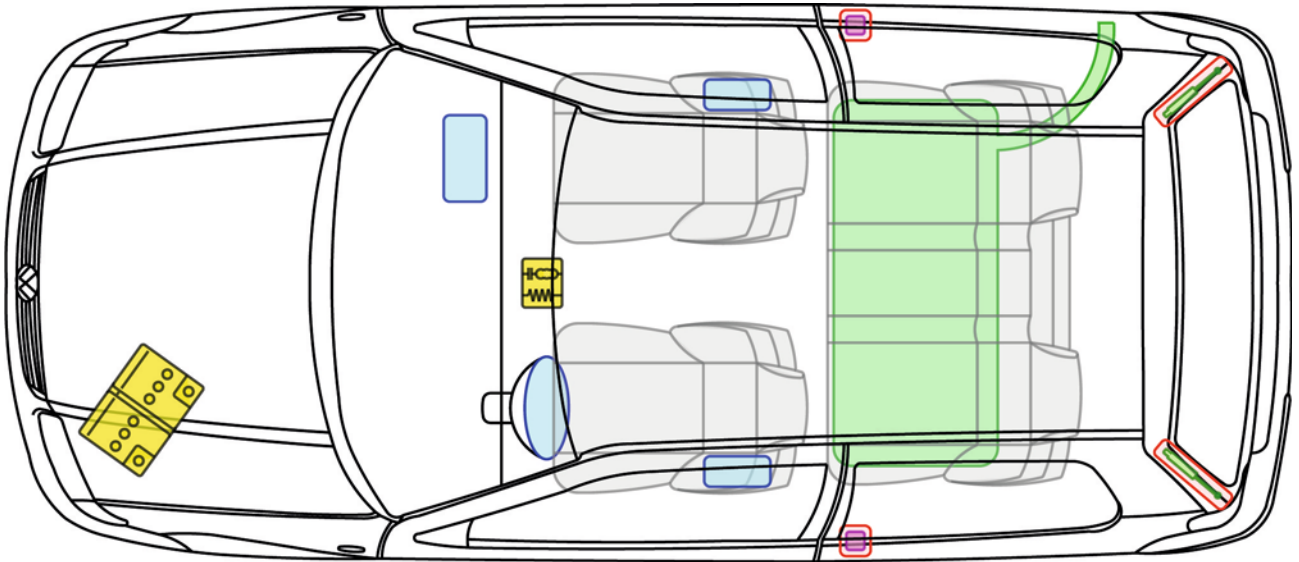

Polo A03

(3-Türer, 1994 - 2001)

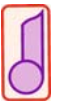

Legende

	Airbag		Karosserie-Verstärkung		Steuergerät	
					12 V-Batterie	
	Gurtstraffer		Gasdruck-dämpfer		Kraftstofftank	







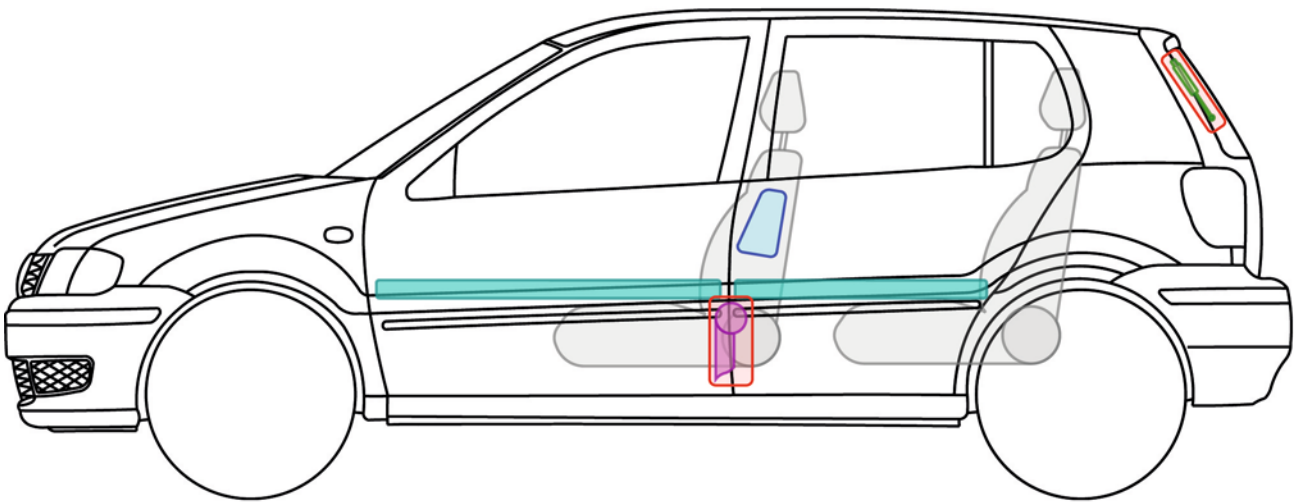
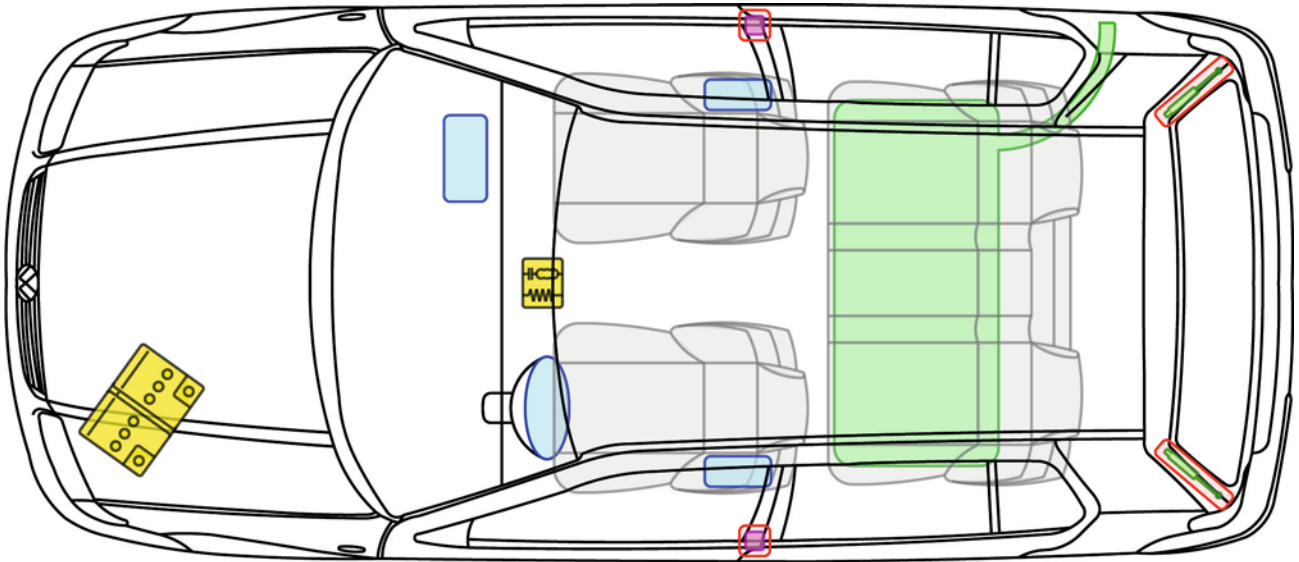

Polo A03

(5-Türer, 1994 - 2001)

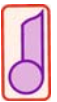

Legende

	Airbag		Karosserie-Verstärkung		Steuergerät
					12 V-Batterie
	Gurtstraffer		Gasdruck-dämpfer		Kraftstofftank







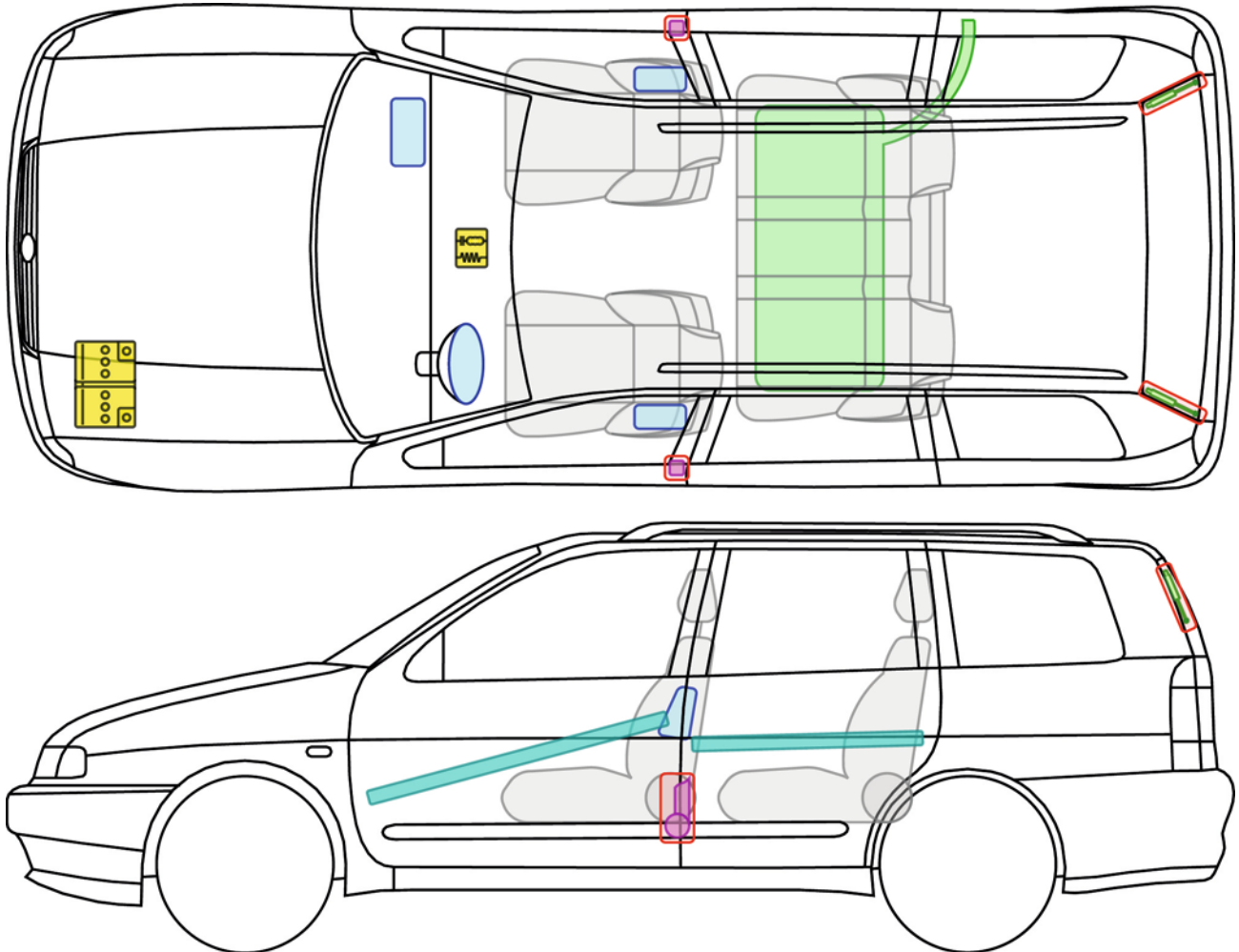

Polo A03

(Variant, 1994 - 2001)

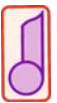

Legende

	Airbag		Karosserie-Verstärkung		Steuergerät	
					12 V-Batterie	
	Gurtstraffer		Gasdruck-dämpfer		Kraftstofftank	







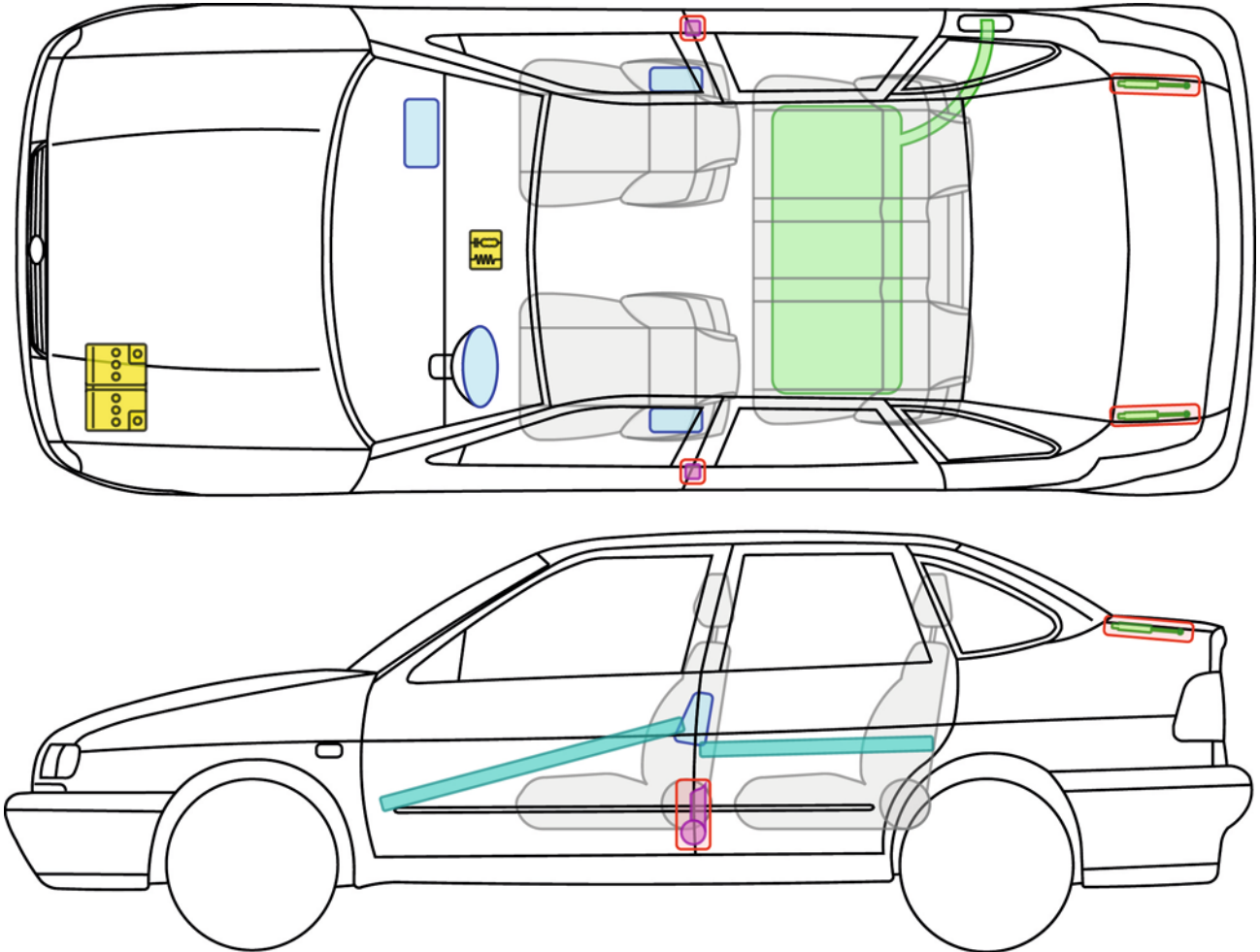

Polo A03

(Stufenheck, 1994 - 2001)

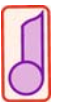

Legende

	Airbag		Karosserie-Verstärkung		Steuergerät
					12 V-Batterie
	Gurtstraffer		Gasdruck-dämpfer		Kraftstofftank







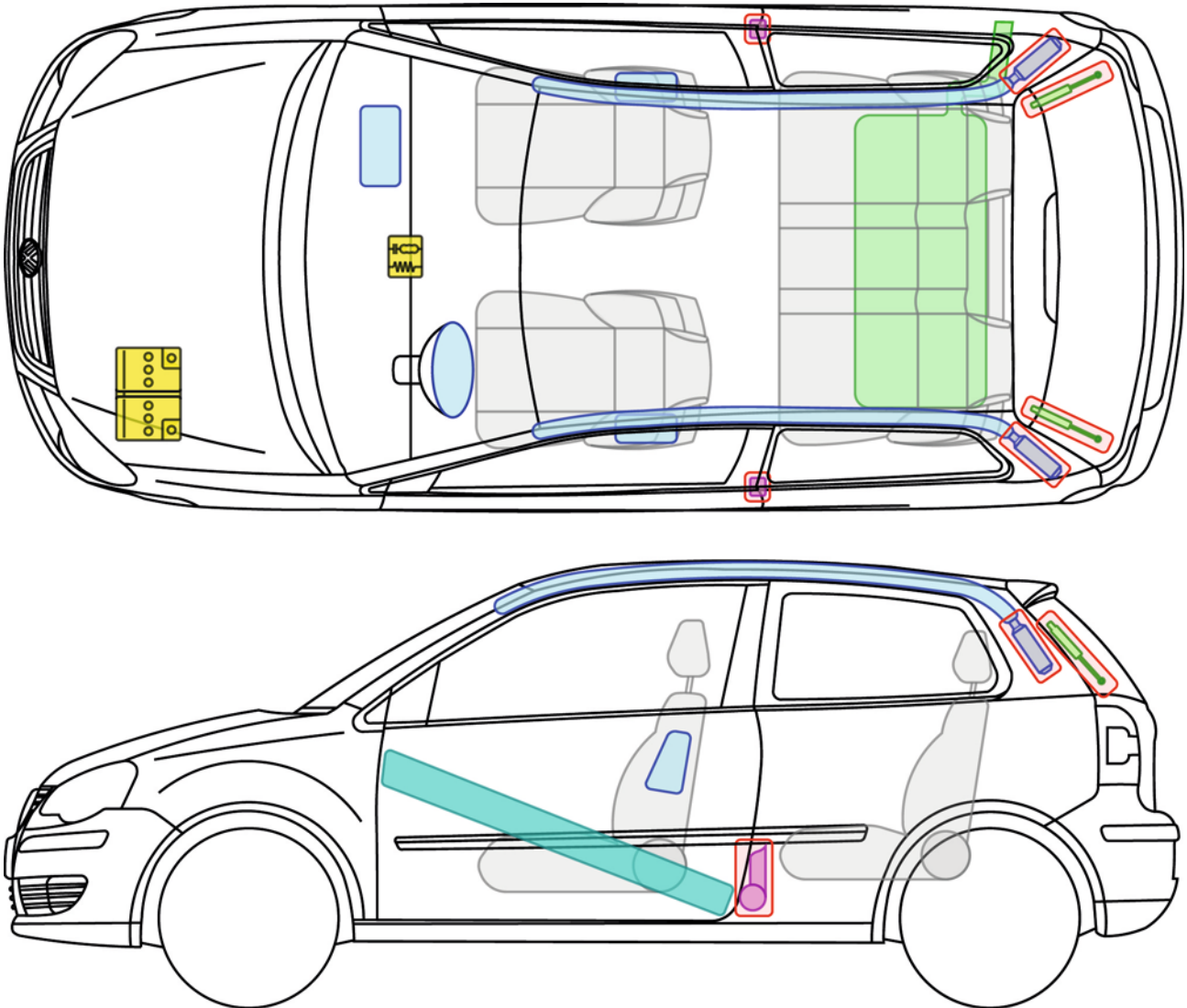



Polo A04

(3-Türer, 2001 - 2009)



Legende

	Airbag		Karosserie-Verstärkung		Steuergerät
	Gas-generator				12 V-Batterie
	Gurtstraffer		Gasdruck-dämpfer		Kraftstofftank







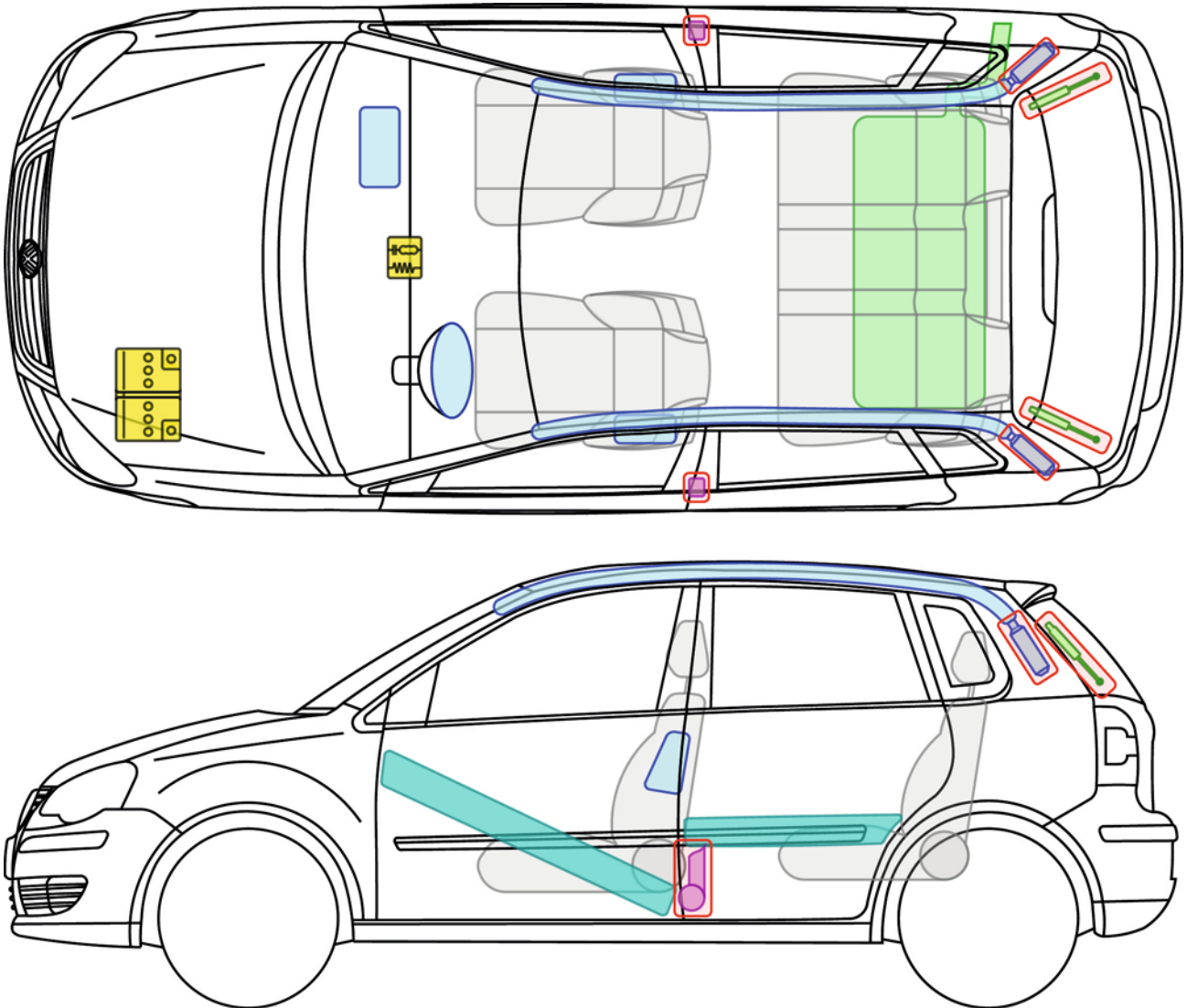



Polo A04

(5-Türer, 2001 - 2009)



Legende

	Airbag		Karosserie-Verstärkung		Steuergerät
	Gas-generator				12 V-Batterie
	Gurtstraffer		Gasdruck-dämpfer		Kraftstofftank







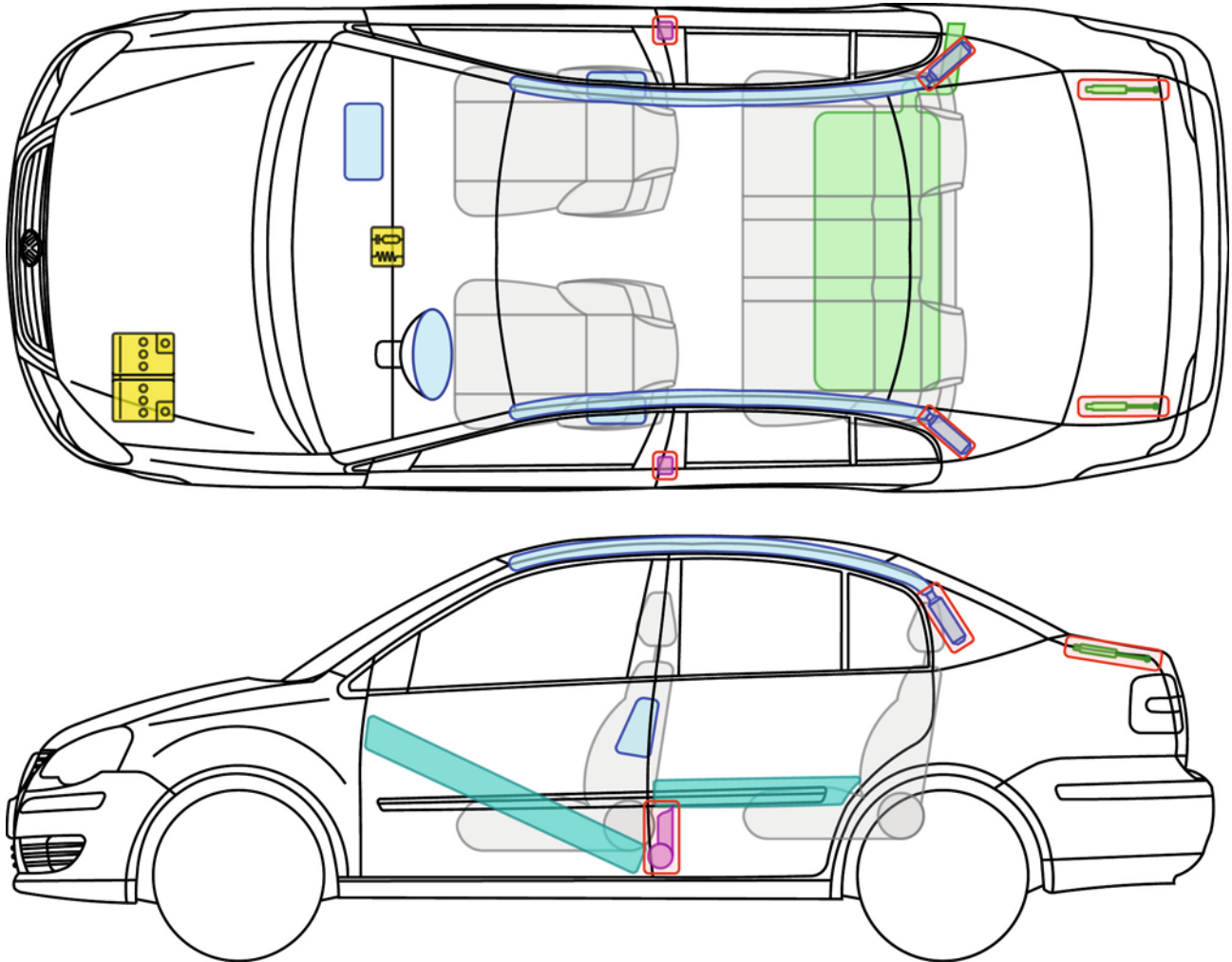



Polo A04

(Stufenheck, 2001 - 2009)



Legende

	Airbag		Karosserie-Verstärkung		Steuergerät	
	Gas-generator				12 V-Batterie	
	Gurtstraffer		Gasdruck-dämpfer		Kraftstofftank	



Polo A05



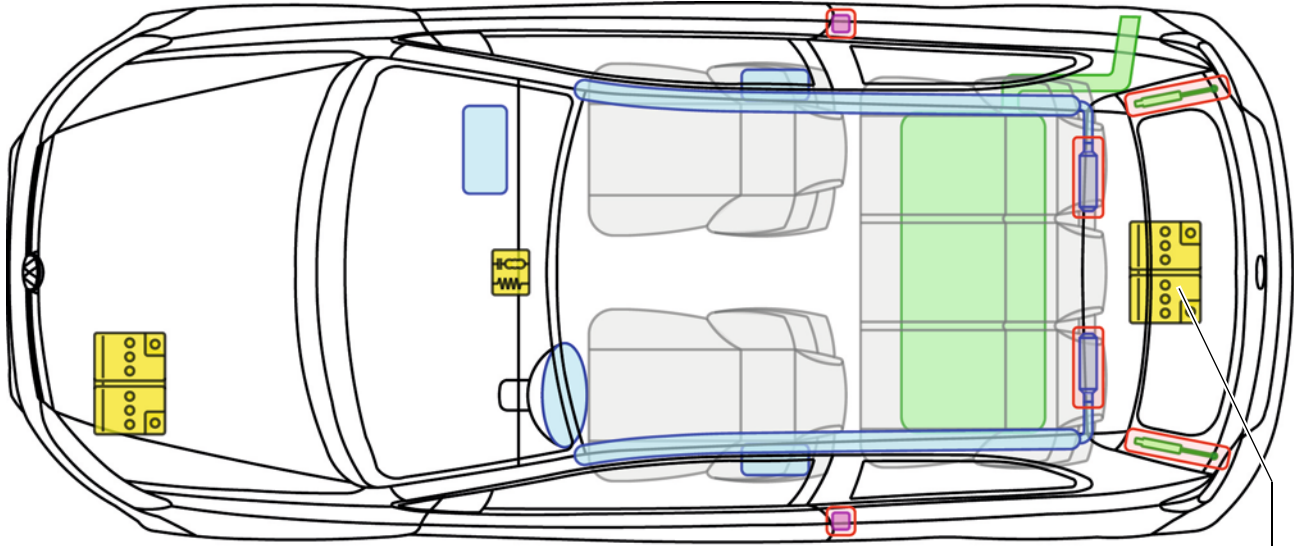



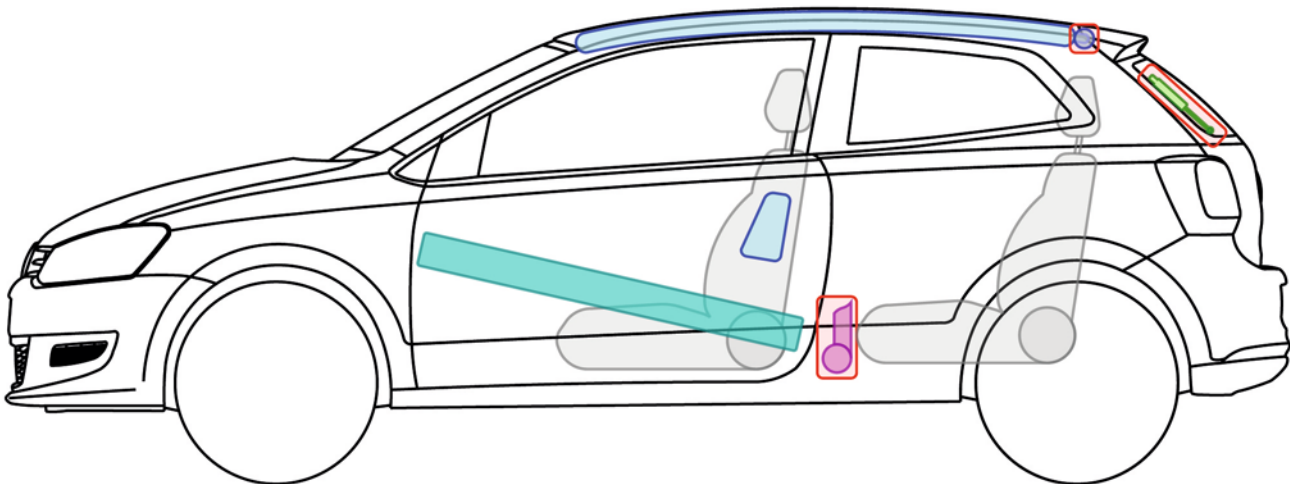

(3-Türer, ab 2009)



Polo A05 GTI Batterie im Kofferraum anstelle Motorraum



Legende

	Airbag		Karosserie-Verstärkung		Steuergerät
	Gas-generator				12 V-Batterie
	Gurtstraffer		Gasdruck-dämpfer		Kraftstofftank



Polo A05



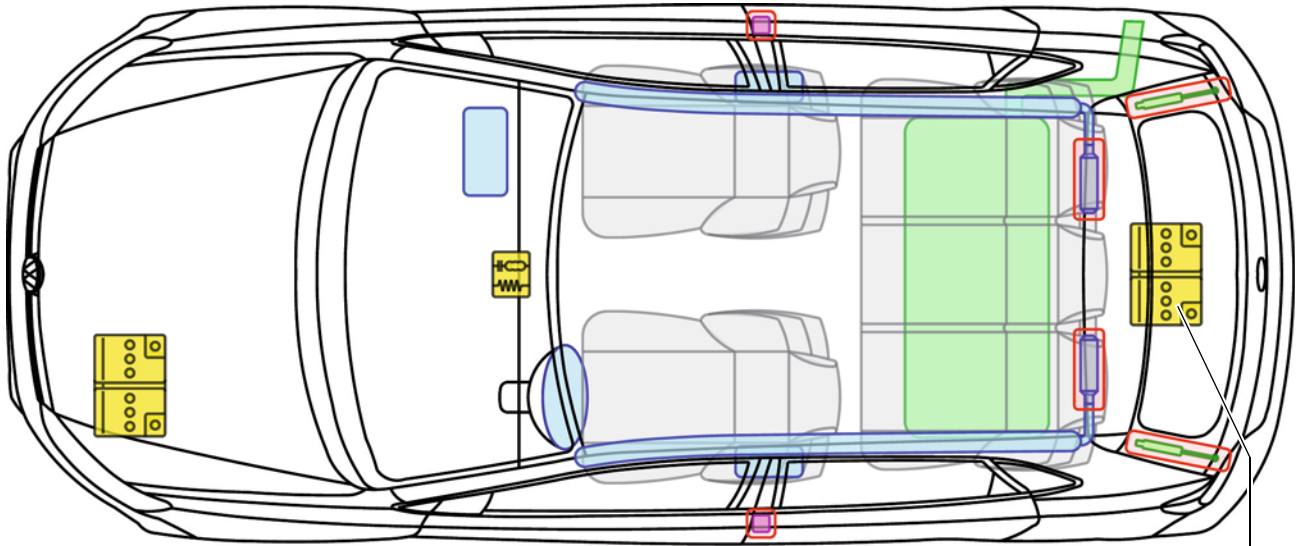



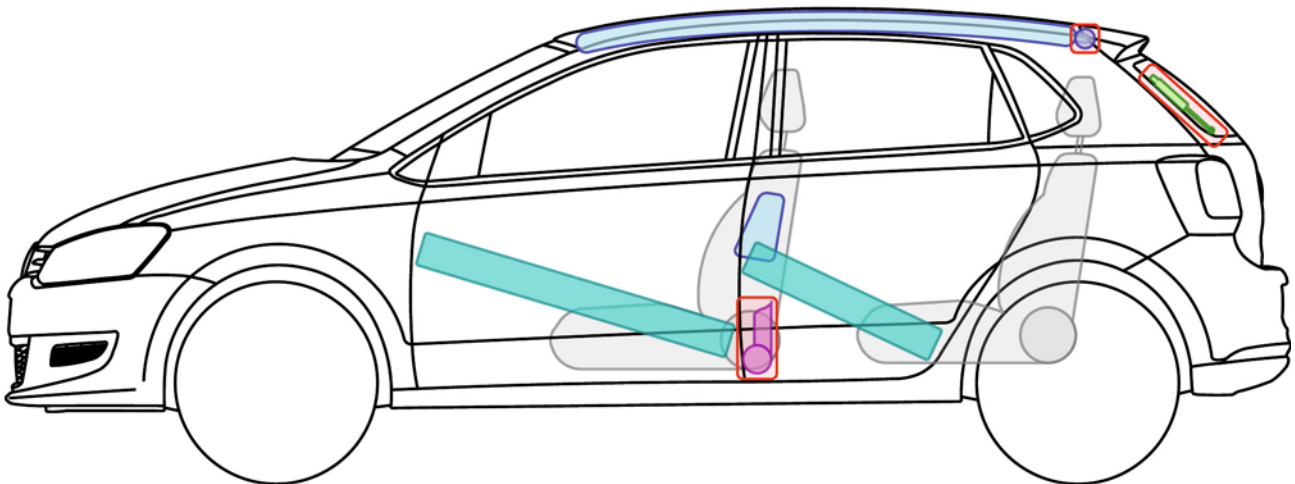

(5-Türer, ab 2009)



mit 2. Batterie nur Polo A05 GTI 5-Türer



Legende

	Airbag		Karosserie-Verstärkung		Steuergerät	
	Gas-generator				12V-Batterie	
	Gurtstraffer		Gasdruck-dämpfer		Kraftstofftank	



Polo A05

(3-Türer BiFuel, ab 2009)

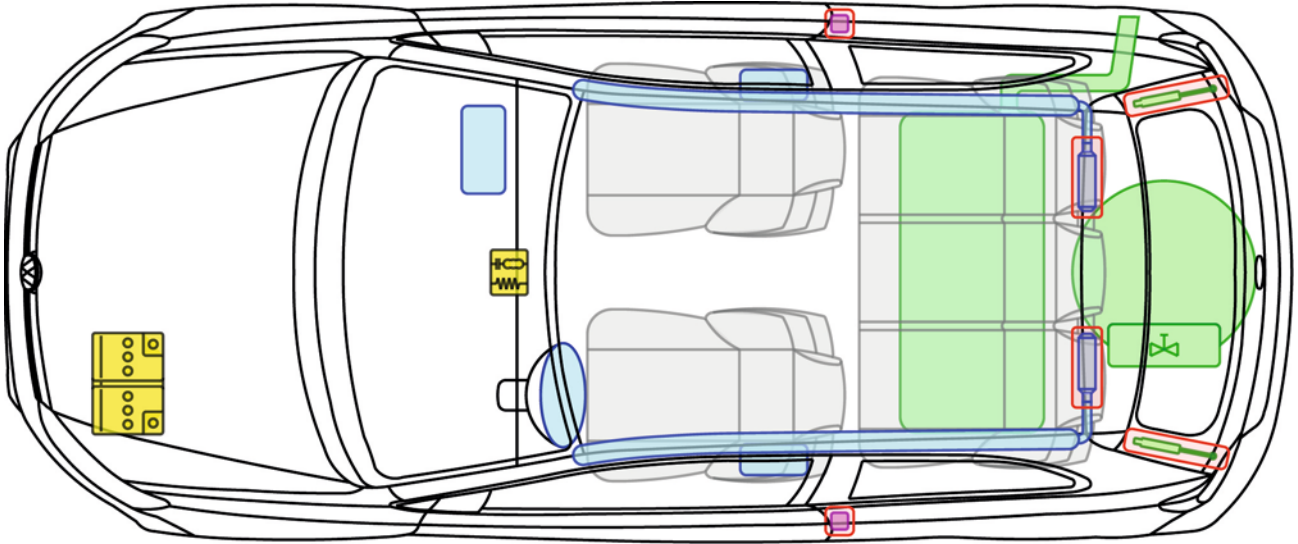





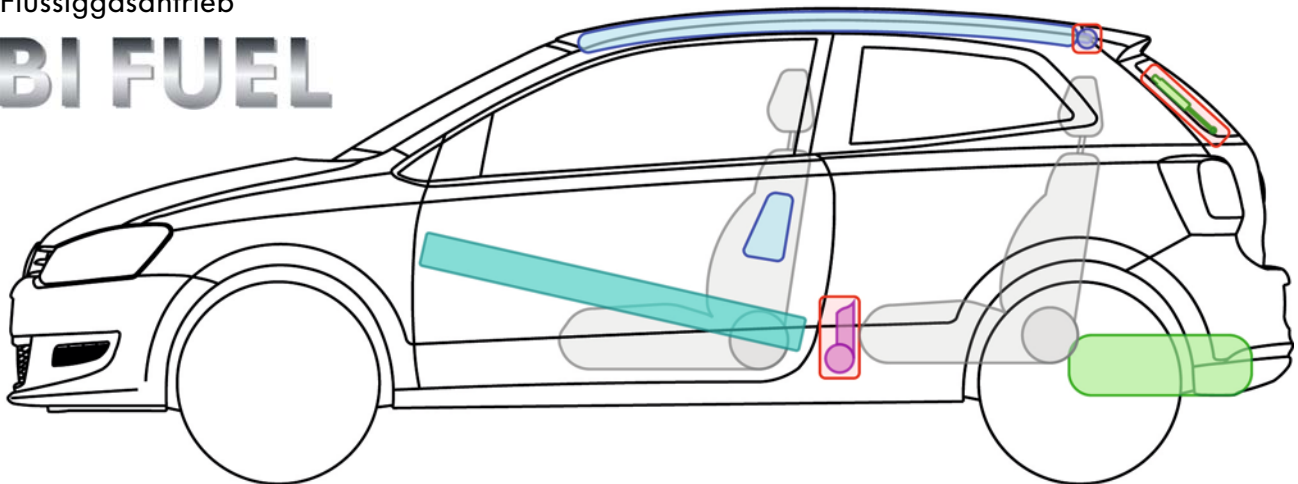

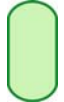

Flüssiggasantrieb

BI FUEL



Legende

	Airbag		Karosserie-Verstärkung		Steuergerät		Gastank
	Gas-generator				12 V-Batterie		Sicherheits-ventil
	Gurtstraffer		Gasdruck-dämpfer		Kraftstofftank		

P

Polo A05 (3-Türer BiFuel, ab 2009)



Polo A05

(3-Türer BiFuel, ab 2009)



Hinweise zur Flüssiggasanlage

Der Gastank der Flüssiggasanlage des Polo A05 BiFuel hat keine mechanische, manuelle Absperrmöglichkeit!



Der Flüssiggastank in der Reserveradmulde (Beispiel Golf)

1. Flüssiggastank lokalisieren

- Er ist unter dem Ladeboden in der Reserveradmulde montiert.
- Der Gastank verfügt nur über ein elektromagnetisches Absperrventil, das stromlos geschlossen ist.



Polo A05

(5-Türer BiFuel, ab 2009)

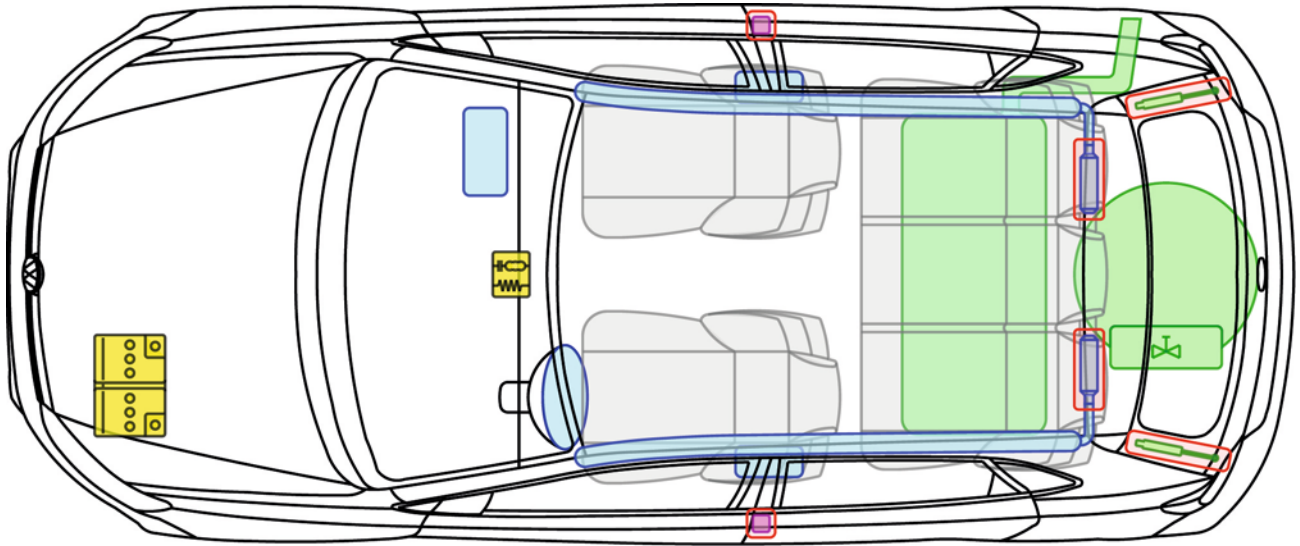





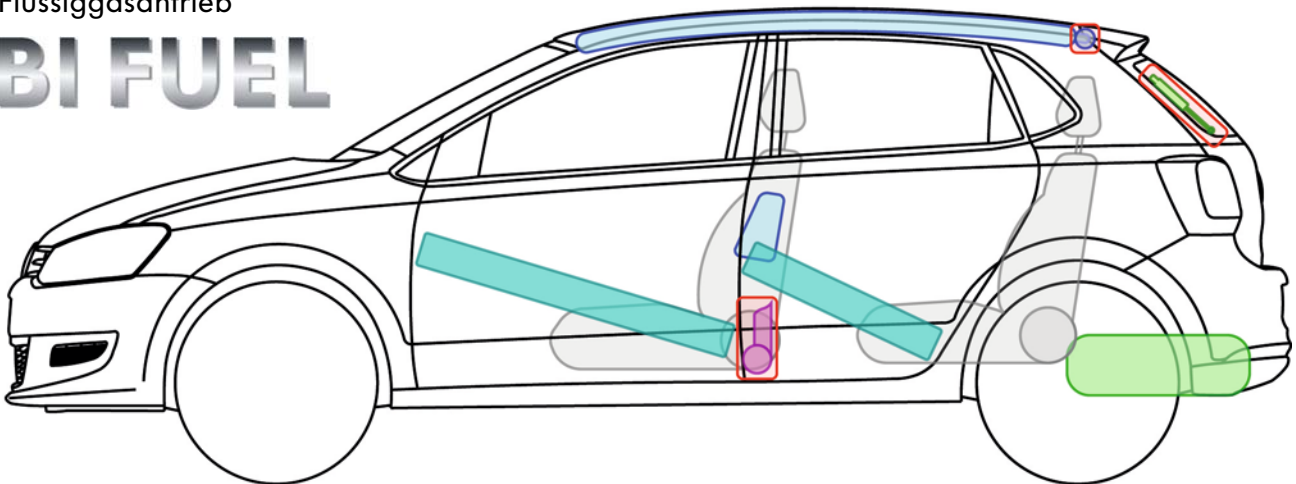

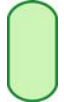

Flüssiggasantrieb

BI FUEL



Legende

	Airbag		Karosserie-Verstärkung		Steuergerät		Gastank
	Gas-generator				12 V-Batterie		Sicherheits-ventil
	Gurtstraffer		Gasdruck-dämpfer		Kraftstofftank		



Polo A05

(5-Türer BiFuel, ab 2009)



Hinweise zur Flüssiggasanlage

Der Gastank der Flüssiggasanlage des Polo A05 BiFuel hat keine mechanische, manuelle Absperrmöglichkeit!



Der Flüssiggastank in der Reserveradmulde (Beispiel Golf)

1. Flüssiggastank lokalisieren

- Er ist unter dem Ladeboden in der Reserveradmulde montiert.
- Der Gastank verfügt nur über ein elektromagnetisches Absperrventil, das stromlos geschlossen ist.







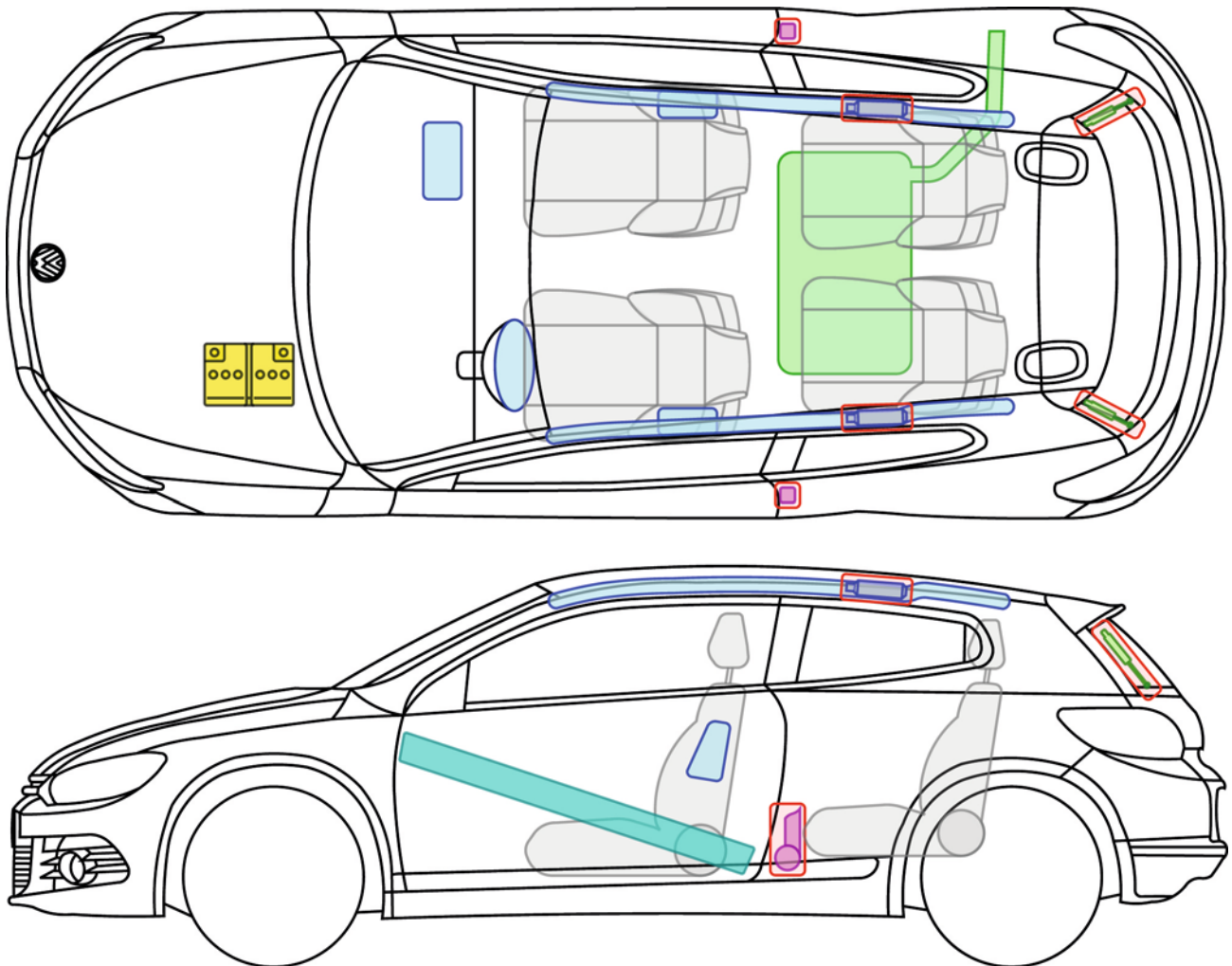



Scirocco

(ab 2008)



Legende

	Airbag		Karosserie-Verstärkung		Steuergerät	
	Gas-generator				12 V-Batterie	
	Gurtstraffer		Gasdruck-dämpfer		Kraftstofftank	



Sharan







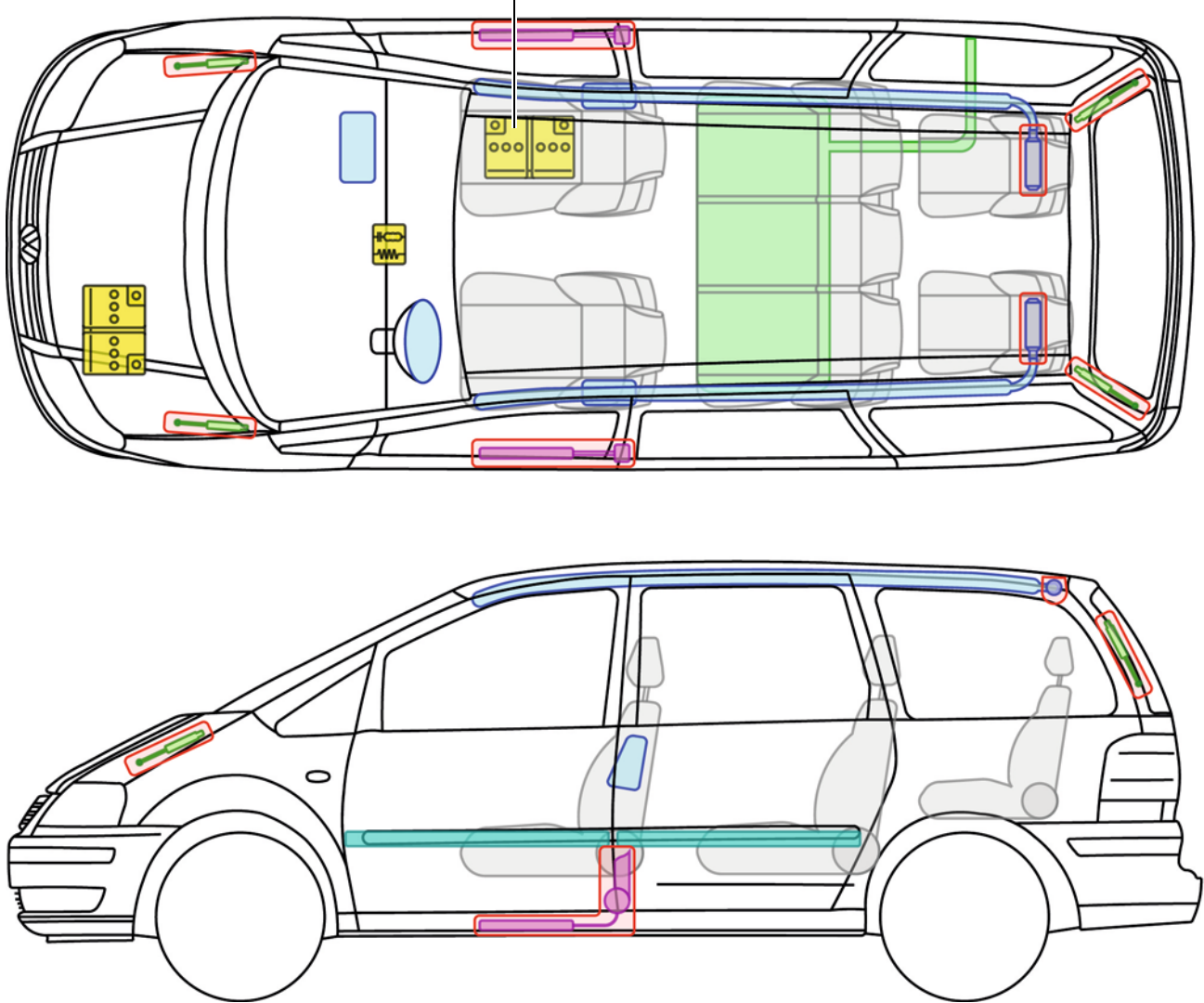

(1995 - 2010)



ausstattungsabhängig zusätzliche Batterie unter dem Beifahrersitz



Legende

	Airbag		Karosserie-Verstärkung		Steuergerät
	Gas-generator				12 V-Batterie
	Gurtstraffer		Gasdruck-dämpfer		Kraftstofftank



Sharan

(BiFuel, ab 2006)



ausstattungsabhängig zusätzliche Batterie unter dem Beifahrersitz

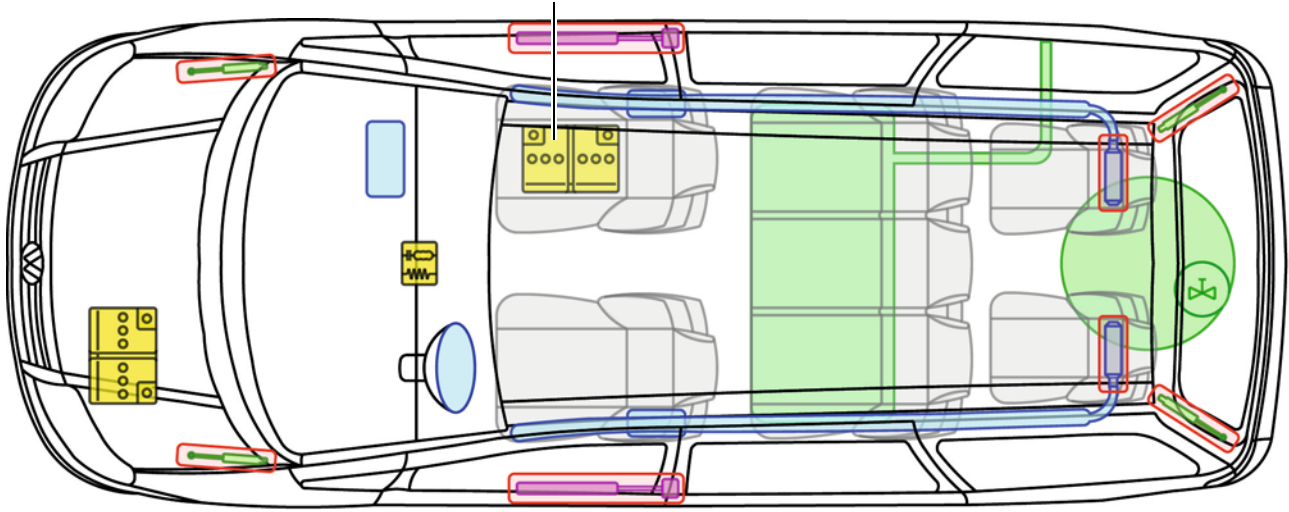





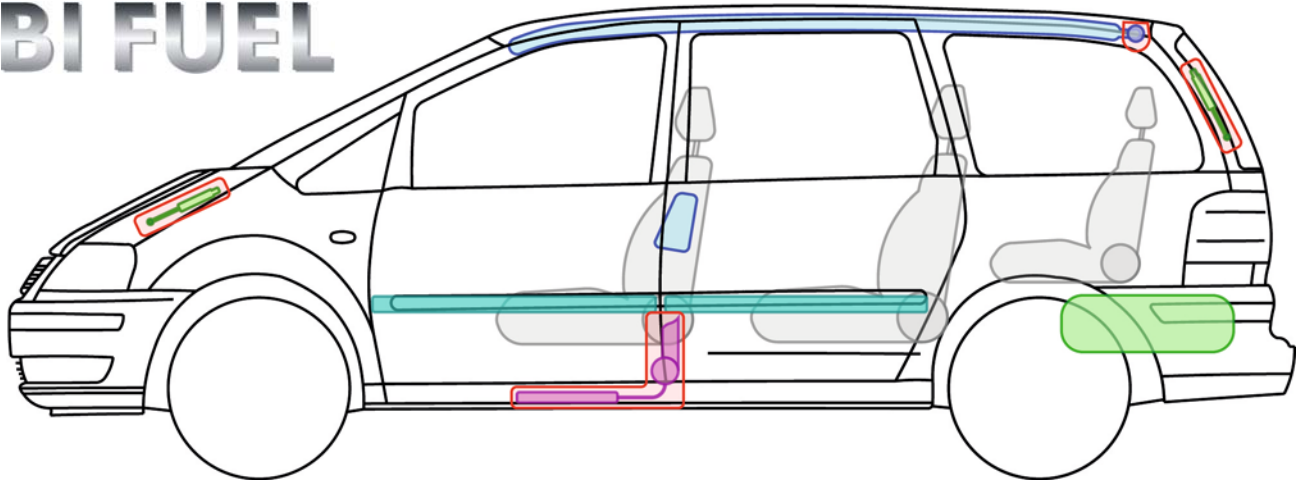

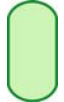

Flüssiggasbetrieb

BI FUEL



Legende

	Airbag		Karosserie-Verstärkung		Steuergerät		Gastank
	Gas-generator				12 V-Batterie		Sicherheits-ventil
	Gurtstraffer		Gasdruck-dämpfer		Kraftstofftank		

S

Sharan (BiFuel, ab 2006)



Sharan

(BiFuel, ab 2006)



Hinweise zur Flüssiggasanlage

Der Gastank der Flüssiggasanlage des Sharan 2006 BiFuel hat keine mechanische, manuelle Absperrmöglichkeit!



Der Flüssiggastank in der Reserveradmulde (Beispiel Golf)

1. Flüssiggastank lokalisieren

- Er ist unter dem Ladeboden in der Reserveradmulde montiert.
- Der Gastank verfügt nur über ein elektromagnetisches Absperrventil, das stromlos geschlossen ist.







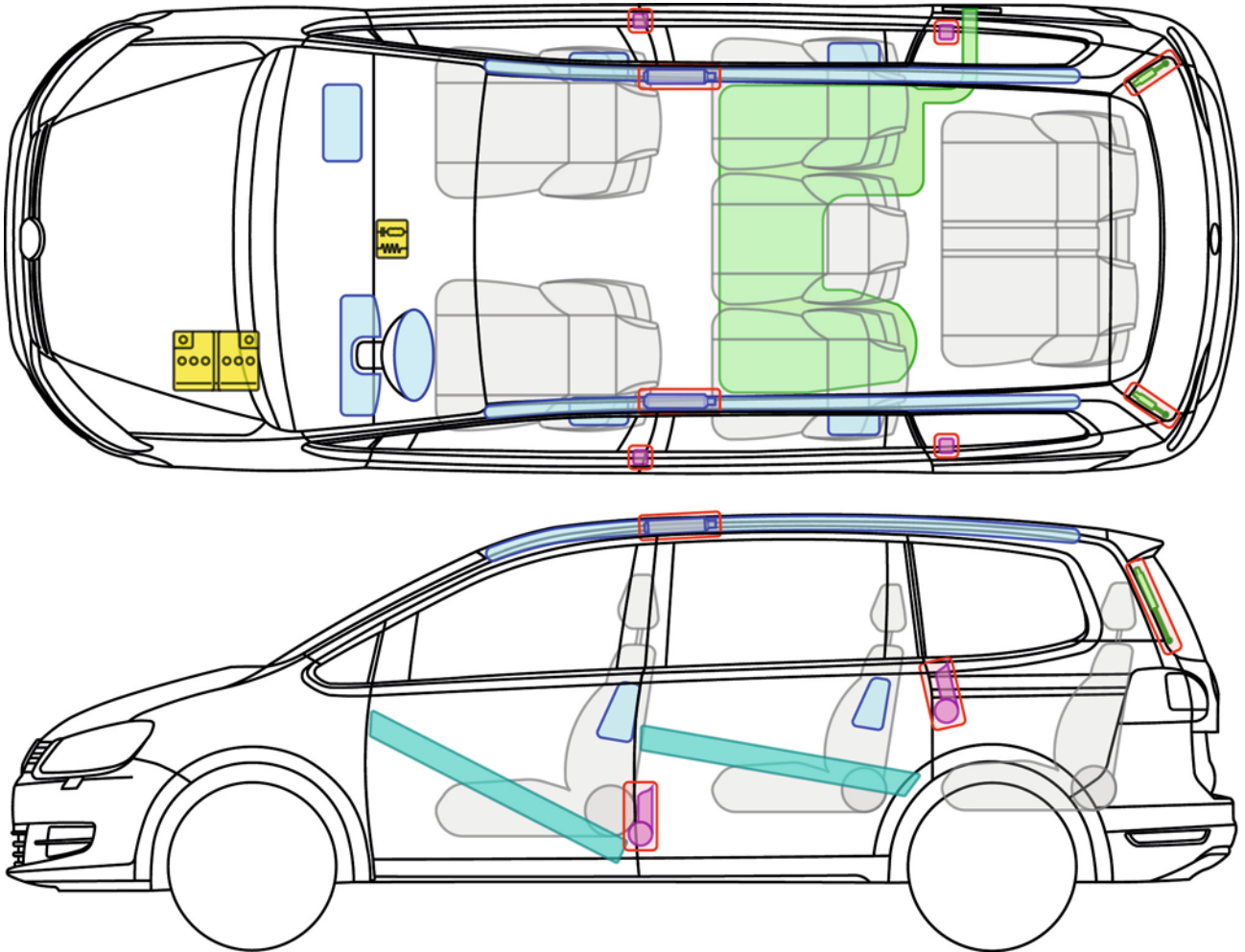



Sharan

(ab 2010)



Legende

	Airbag		Karosserie-Verstärkung		Steuergerät
	Gas-generator				12 V-Batterie
	Gurtstraffer		Gasdruck-dämpfer		Kraftstofftank







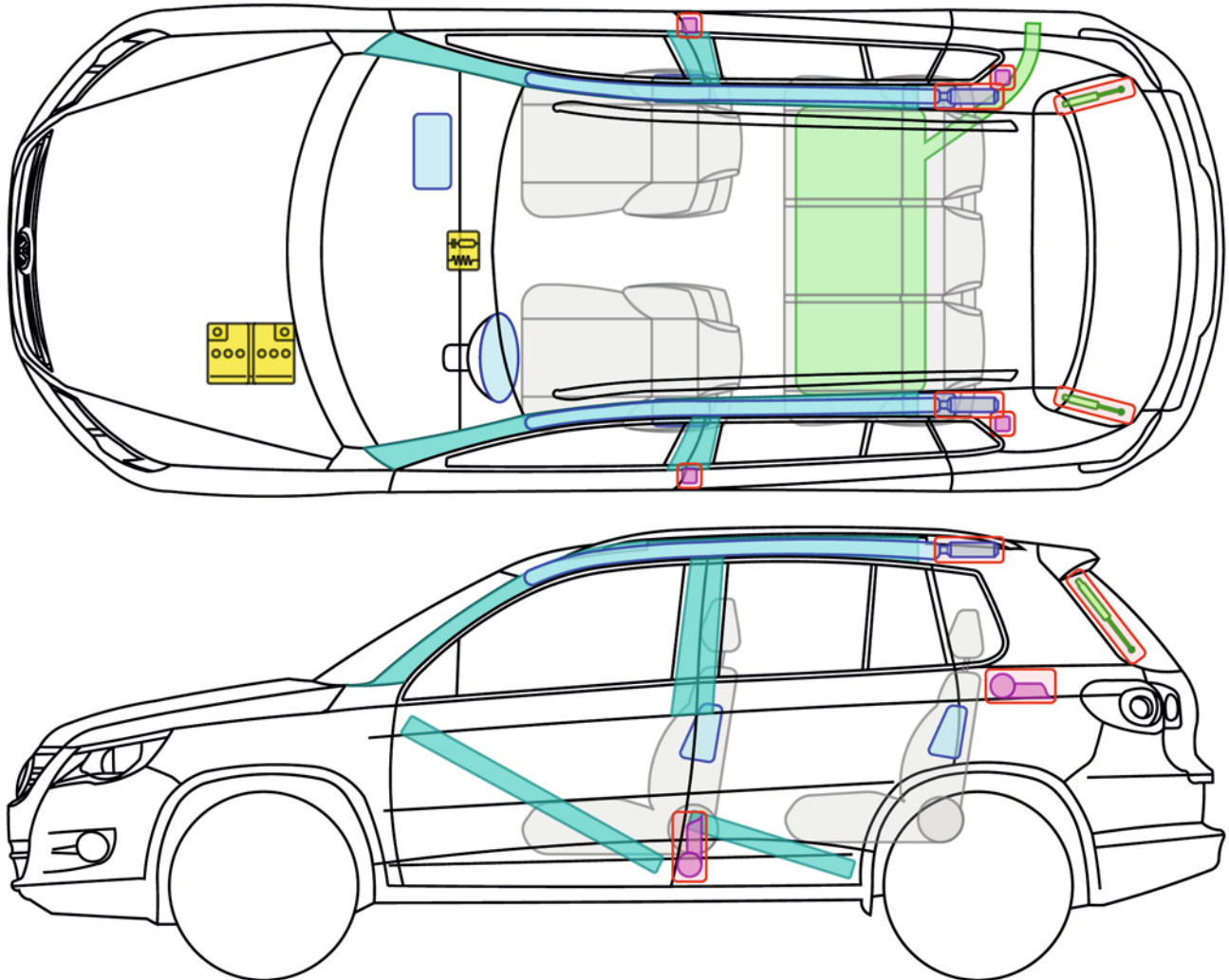



Tiguan

(ab 2007)



Legende

	Airbag		Karosserie-Verstärkung		Steuergerät	
	Gas-generator				12 V-Batterie	
	Gurtstraffer		Gasdruck-dämpfer		Kraftstofftank	



Fahrzeug deaktivieren

Batterien abklemmen

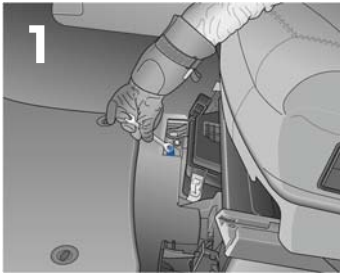

1. Startbatterie abklemmen

- Teppich vor dem Fahrersitz entfernen
- Masseanschluss der Startbatterie im Boden vor dem Fahrersitz lokalisieren
- Masseanschluss von der Karosserie trennen

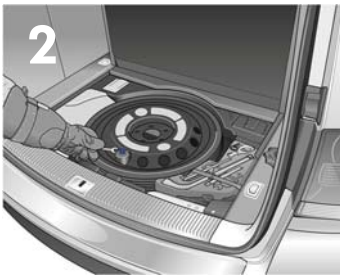

2. Zusatzbatterie im Kofferraum lokalisieren

- Nach Möglichkeit Information einholen, ob Zusatzbatterie verbaut ist
- Ladeboden im Kofferraum anheben
- Reserverad entfernen

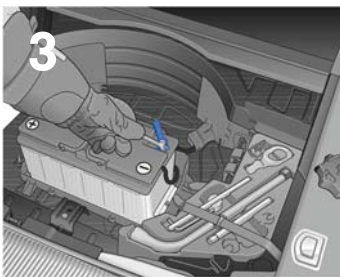

3. Zusatzbatterie am Masseanschluss (-) abklemmen







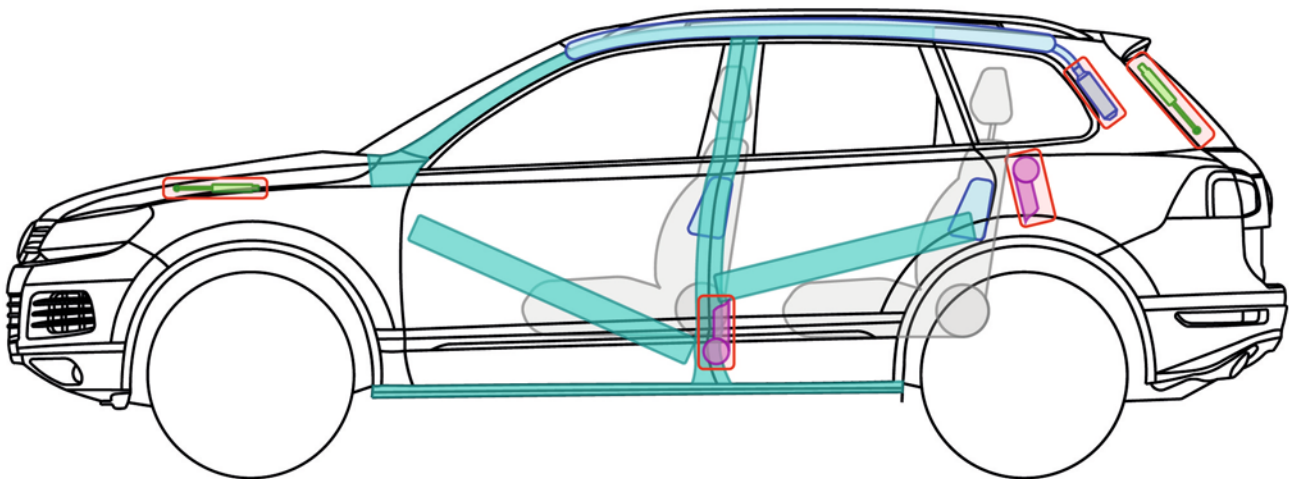
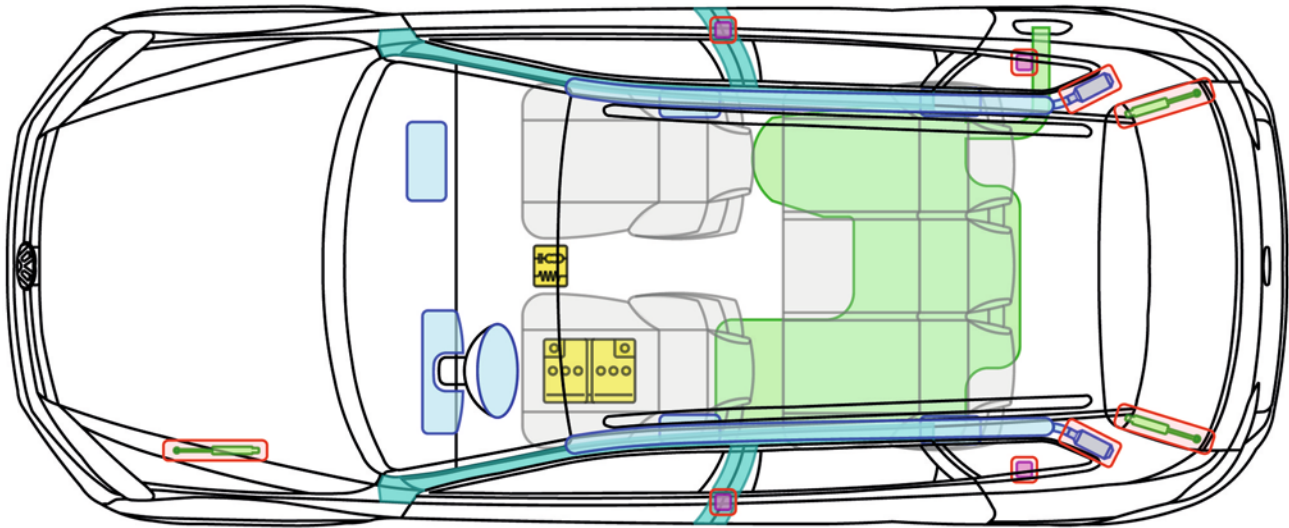

Touareg

(ab 2010)

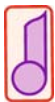

Legende

	Airbag		Karosserie-Verstärkung		Steuergerät	
	Gas-generator				12V-Batterie	
	Gurtstraffer		Gasdruck-dämpfer		Kraftstofftank	



Fahrzeug deaktivieren

Batterien abklemmen



1. Zugang zur Masseverbindung der 12V-Batterie lokalisieren.

- Fahrersitz, falls möglich, zurückfahren.
- Abdeckung der Masseverbindung im Boden vor dem Fahrersitz lokalisieren

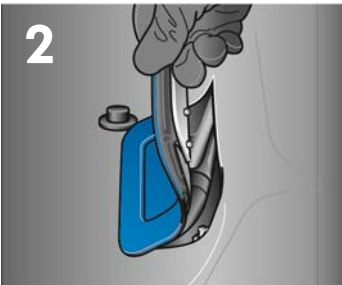

2. Abdeckung (Teppichausschnitt) lösen und aufklappen

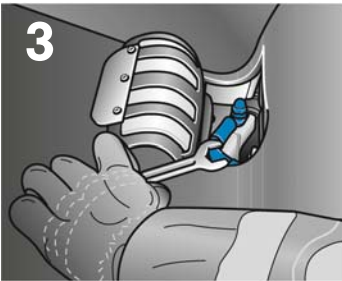

3. Masseverbindung an der Verschraubung trennen



Touareg

(Hybrid, ab 2010)

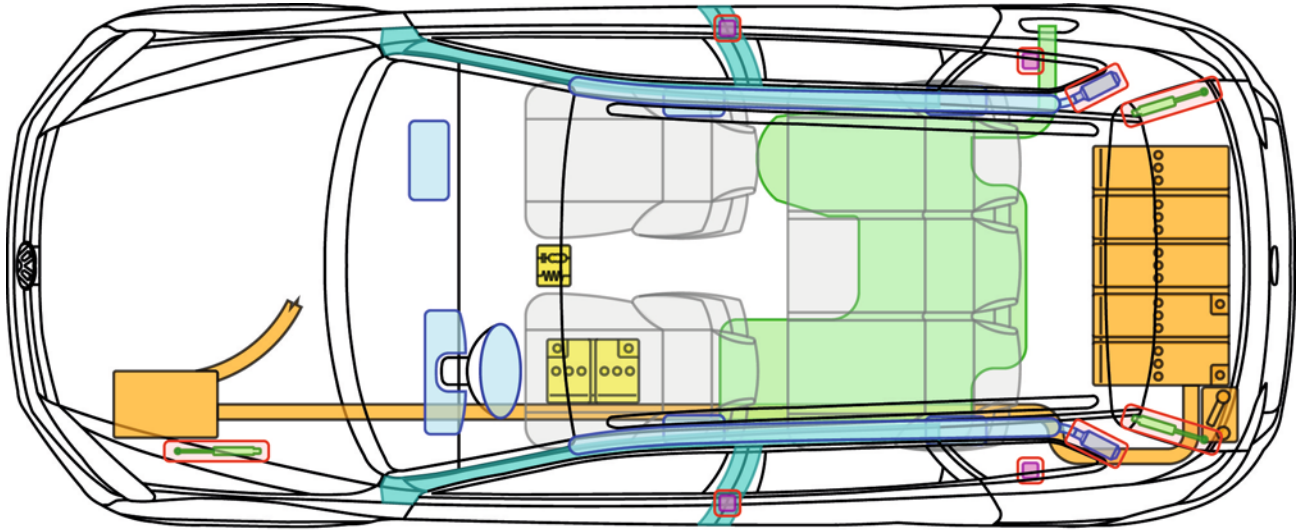





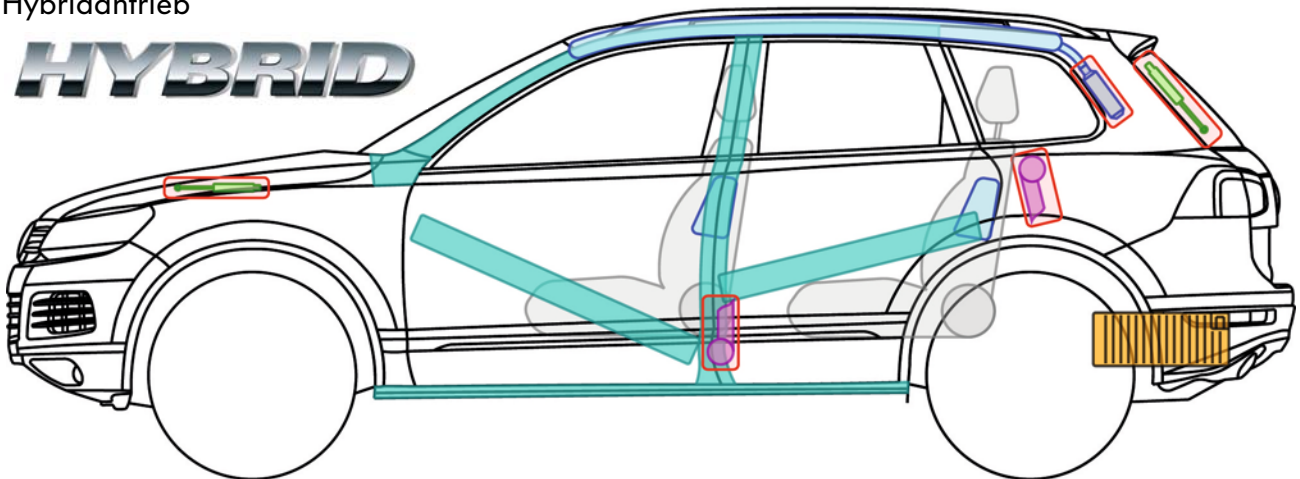





Hybridantrieb

HYBRID

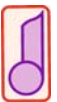

Legende

	Airbag		Karosserie-Verstärkung		Steuergerät		Hochvolt-batterie
	Gas-generator				12 V-Batterie		Hochvolt-leitung/-komponente
	Gurtstraffer		Gasdruck-dämpfer		Kraftstofftank		Trennstelle für Hochvolt



Touareg

(Hybrid, ab 2010)



Fahrzeugidentifizierung

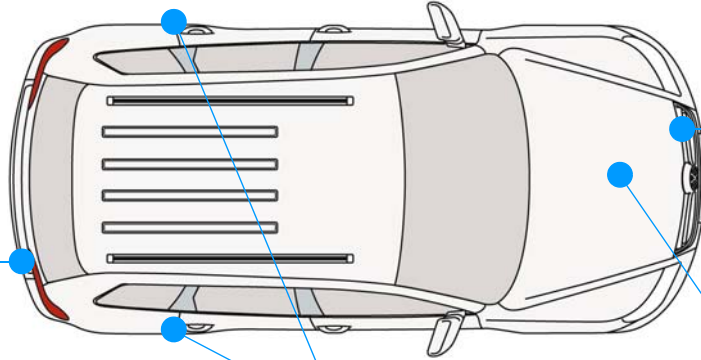

vorn im Kühlergrill

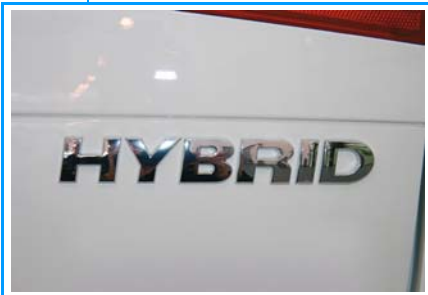

auf der Heckklappe



auf den seitlichen Chromleisten



auf der Designabdeckung

Fahrzeug gegen Wegrollen sichern

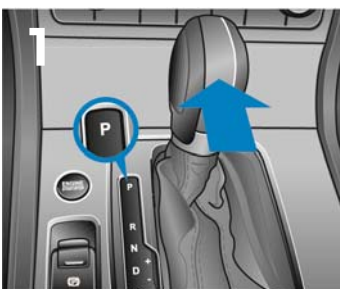

1. Gangwahlhebel in Stellung "P" bringen



2. Elektrische Feststellbremse betätigen

- Schalter nach oben ziehen

T

Touareg (Hybrid, ab 2010)



Fahrzeug deaktivieren

Antrieb und Hochvoltsystem deaktivieren (Zündung und 12V-Batterie zugänglich)



1. Bei laufendem Motor Zündschlüssel aus der Neutralstellung nach links oder rechts drehen, um Motor auszuschalten. Zündschlüssel nach Möglichkeit abziehen.

oder



2. Start/Stop-Knopf bis zur zweiten Stufe durchdrücken



3. Zugang zur Masseverbindung der 12V-Batterie lokalisieren. Fahrersitz, falls möglich, zurückfahren.



4. Teppichausschnitt lösen

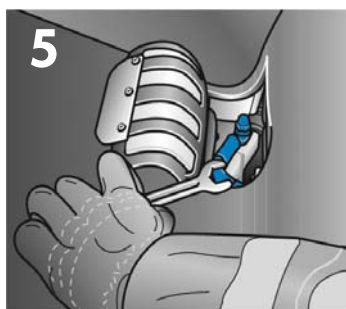

5. Masseverbindung an der Verschraubung trennen



Das Hochvoltsystem ist nach dem Ausschalten der Zündung innerhalb von ca. 20 Sekunden spannungsfrei. Die passiven Sicherheitssysteme wie Airbags und Gurtstraffer sind deaktiviert.



Fahrzeug deaktivieren

Hochvoltsystem deaktivieren

(Zündung und 12V-Batterie NICHT zugänglich)

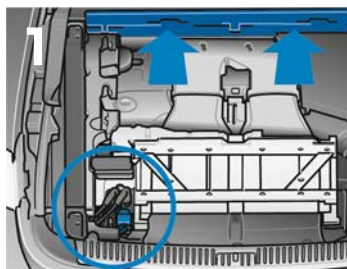

1. Ladeboden des Kofferraumes anheben

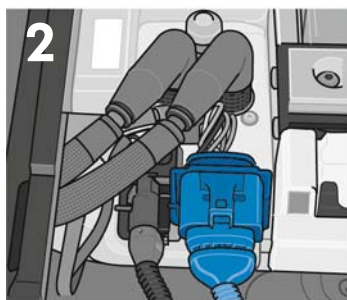

2. Trennstelle lokalisieren

- Die zu trennende 12V-Steckverbindung befindet sich an der E-Box auf der linken Seite der Hochvoltbatterie neben der Hochvoltleitung

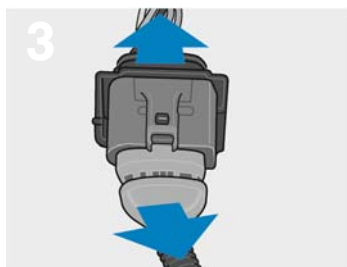

3. Steckverbindung trennen



Das Hochvoltsystem ist nach dem Trennen der Steckverbindung innerhalb von ca. 20 Sekunden spannungsfrei. Die passiven Sicherheitssysteme wie Airbags und Gurtstraffer werden durch die 12V-Batterie weiterhin mit Spannung versorgt.

Bei Unfällen mit Airbag und/oder Gurtstraffer-auslösung wird das Hochvoltsystem automatisch deaktiviert.







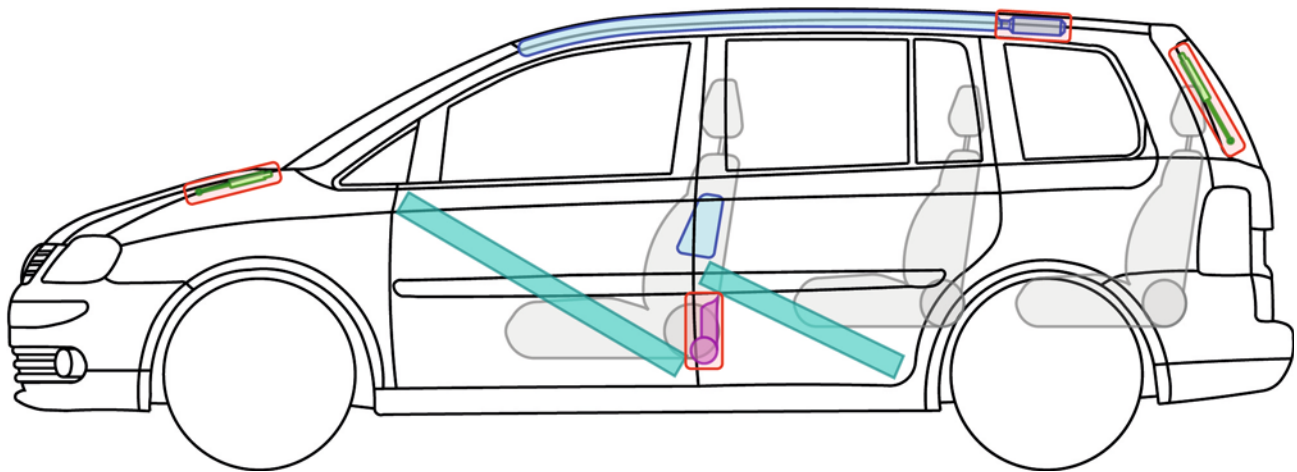
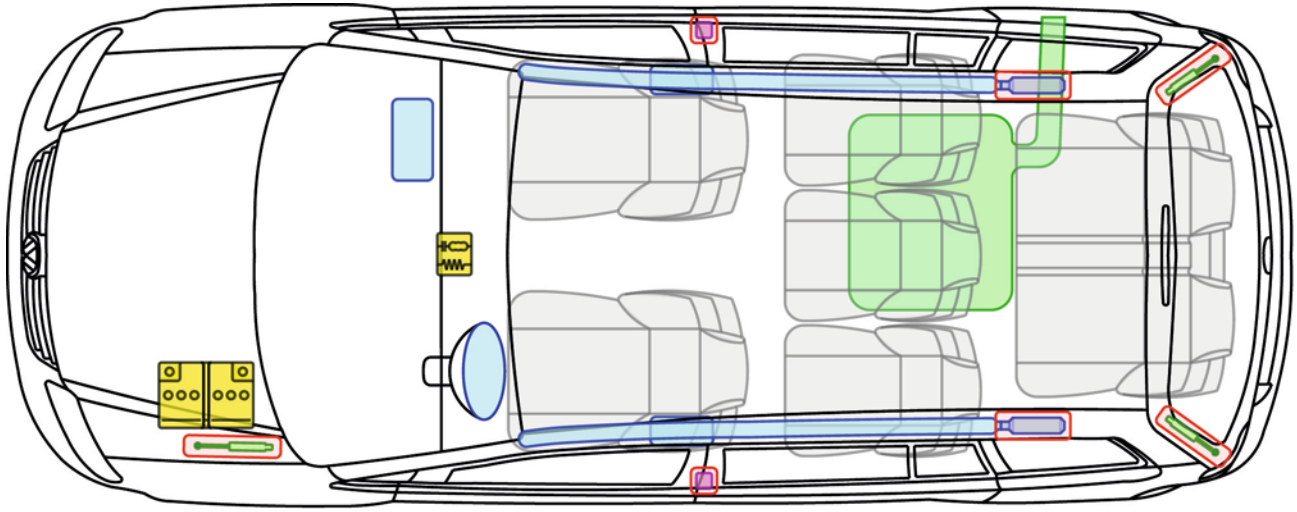



Touran

(2003 - 2006)



Legende

	Airbag		Karosserie-Verstärkung		Steuergerät
	Gas-generator				12V-Batterie
	Gurtstraffer		Gasdruck-dämpfer		Kraftstofftank



Touran

(EcoFuel, 2005 - 2006)

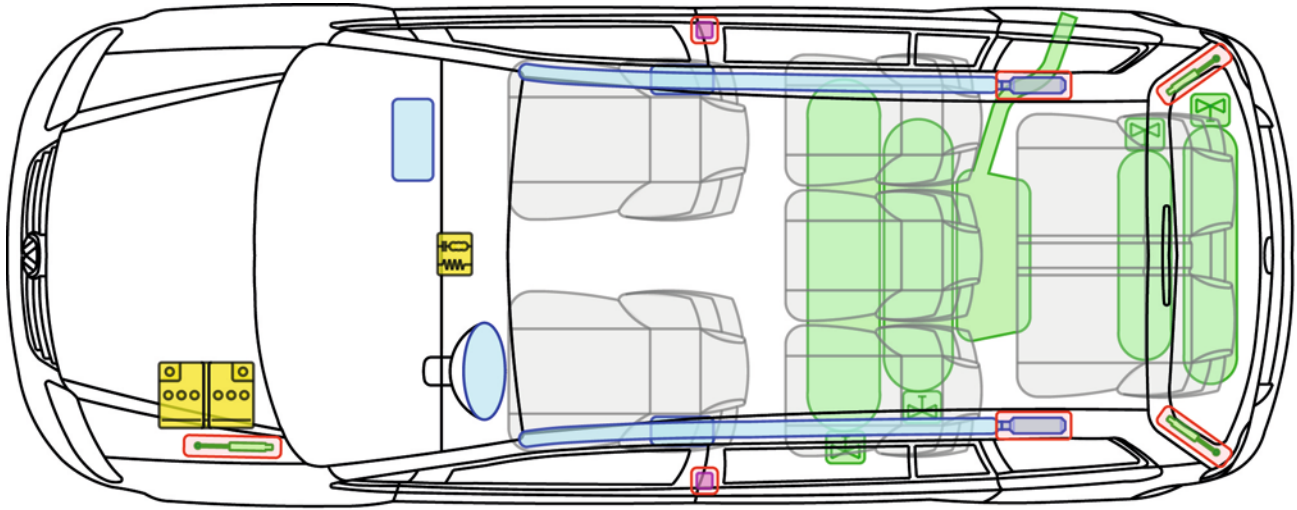





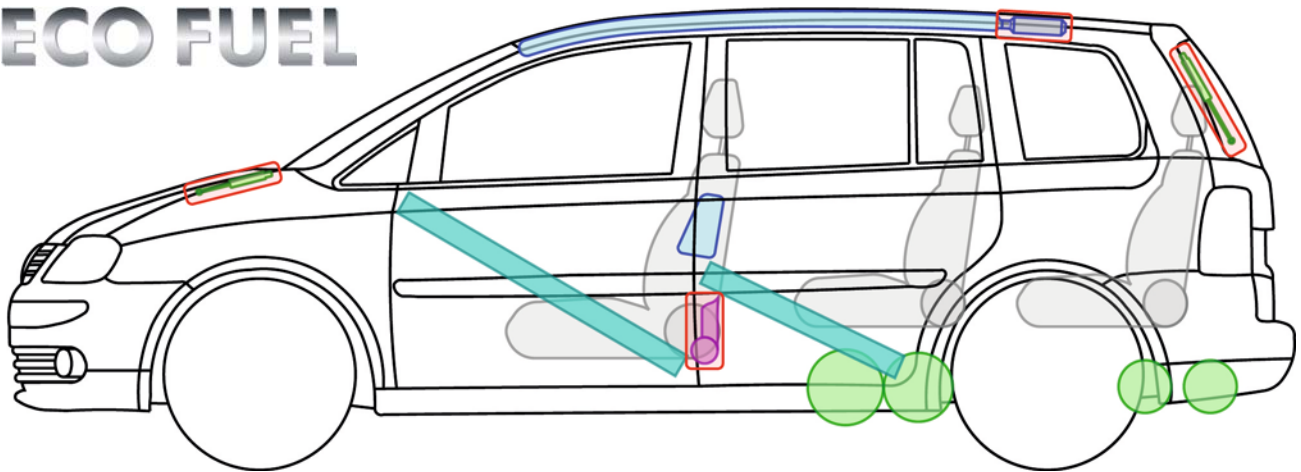

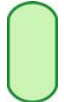

Erdgasantrieb

ECO FUEL

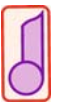

Legende

	Airbag		Karosserie-Verstärkung		Steuergerät		Gastank
	Gas-generator				12 V-Batterie		Sicherheits-ventil
	Gurtstraffer		Gasdruck-dämpfer		Kraftstofftank		



Hinweise zur Erdgasanlage

Gastanks manuell absperrn (bei Gasgeruch bzw. Austritt von Erdgas)

1. Zugang zu den Erdgastanks

- Der Zugang zu den Tanks erfolgt vom Unterboden aus.
- Die Gastanks sind durch eine Kunststoffabdeckung verkleidet. Um an die Erdgastanks zu gelangen, muss diese Abdeckung mit geeigneten Mitteln entfernt werden, ohne die darunter liegenden Bauteile der Gasanlage zu beschädigen.

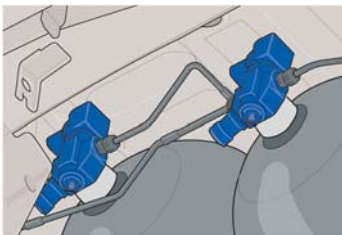

elektromagnetische Absperrventile an den Gastanks

2. Absperrhähne lokalisieren

- Jeder Gastank besitzt ein eigenes Flaschenventil mit einem manuellen Absperrhahn.
- Falls einsatzbedingt erforderlich muss jeder Gastank separat abgesperrt werden.



manueller Absperrhahn seitlich am Flaschenventil (bis 2008).

3. Gastank von Hand schließen

- Falls einsatzbedingt erforderlich muss jeder Gastank separat abgesperrt werden.
- Mit einem 5er-Maul- bzw. Ringschlüssel lässt sich das manuelle Absperrventil am Vierkant durch Drehen im Uhrzeigersinn bis zum Anschlag des Ventils verschließen.







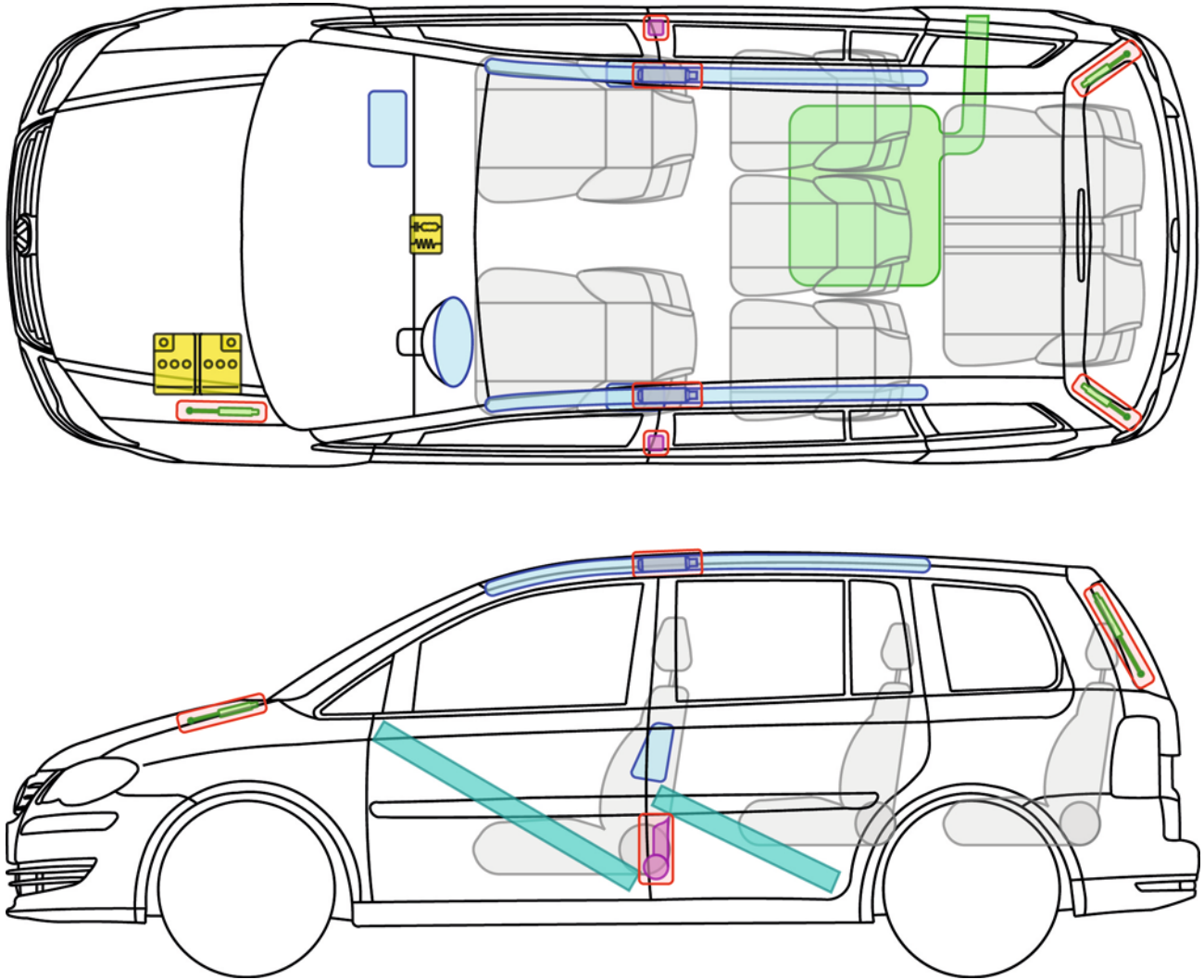



Touran

(2006 - 2010)



Legende

	Airbag		Karosserie-Verstärkung		Steuergerät
	Gas-generator				12 V-Batterie
	Gurtstraffer		Gasdruck-dämpfer		Kraftstofftank



Touran

(EcoFuel, 2006 - 2010)

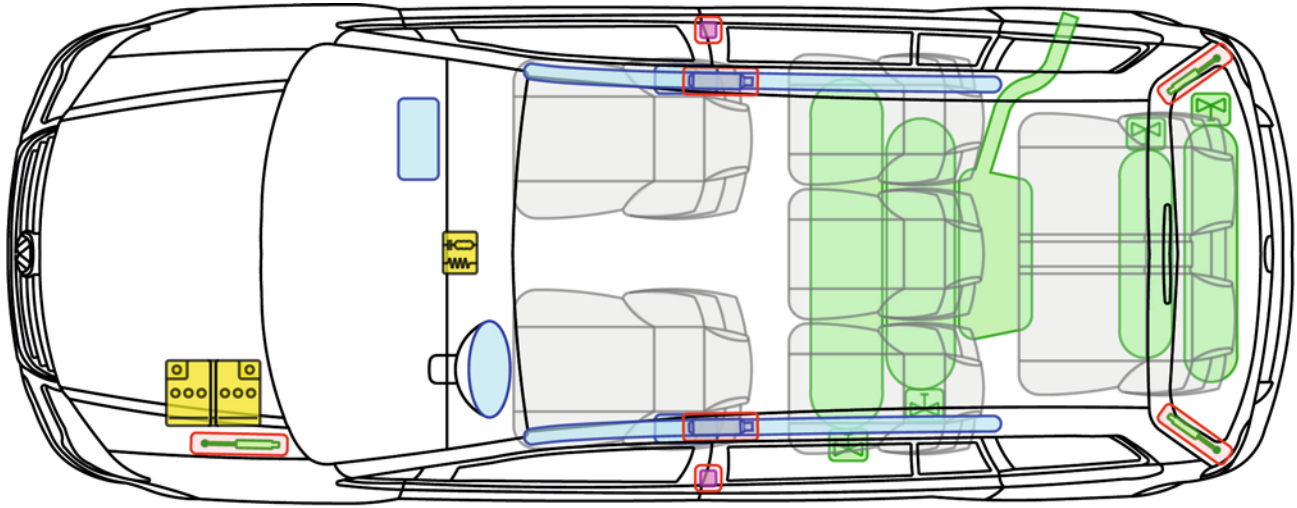





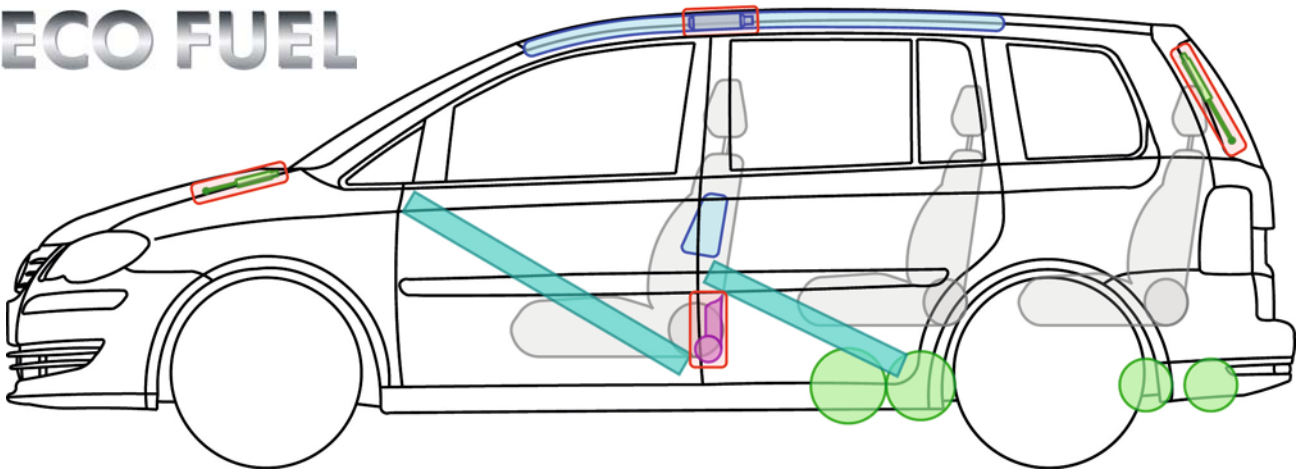

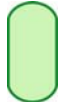

Erdgasantrieb

ECO FUEL

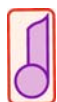

Legende

	Airbag		Karosserie-Verstärkung		Steuergerät		Gastank
	Gas-generator				12 V-Batterie		Sicherheits-ventil
	Gurtstraffer		Gasdruck-dämpfer		Kraftstofftank		



Hinweise zur Erdgasanlage

Gastanks manuell absperrn (bei Gasgeruch bzw. Austritt von Erdgas)

1. Zugang zu den Erdgastanks

- Der Zugang zu den Tanks erfolgt vom Unterboden aus.
- Die Gastanks sind durch eine Kunststoffabdeckung verkleidet. Um an die Erdgastanks zu gelangen, muss diese Abdeckung mit geeigneten Mitteln entfernt werden, ohne die darunter liegenden Bauteile der Gasanlage zu beschädigen.

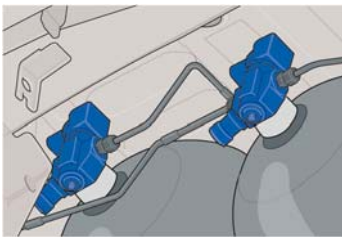

elektromagnetische Absperrventile an den Gastanks

2. Absperrhähne lokalisieren

- Jeder Gastank besitzt ein eigenes Flaschenventil mit einem manuellen Absperrhahn.
- Falls einsatzbedingt erforderlich muss jeder Gastank separat abgesperrt werden.

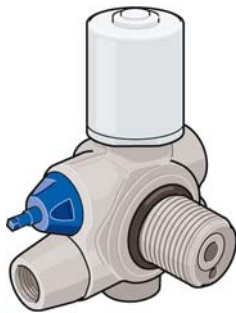

manueller Absperrhahn seitlich am Flaschenventil (bis 2008).

3. Gastank von Hand schließen

- Falls einsatzbedingt erforderlich muss jeder Gastank separat abgesperrt werden.
- Mit einem 5er-Maul- bzw. Ringschlüssel lässt sich das manuelle Absperrventil am Vierkant durch Drehen im Uhrzeigersinn bis zum Anschlag des Ventils verschließen.



manueller Absperrhahn am Fuß des Flaschenventils.







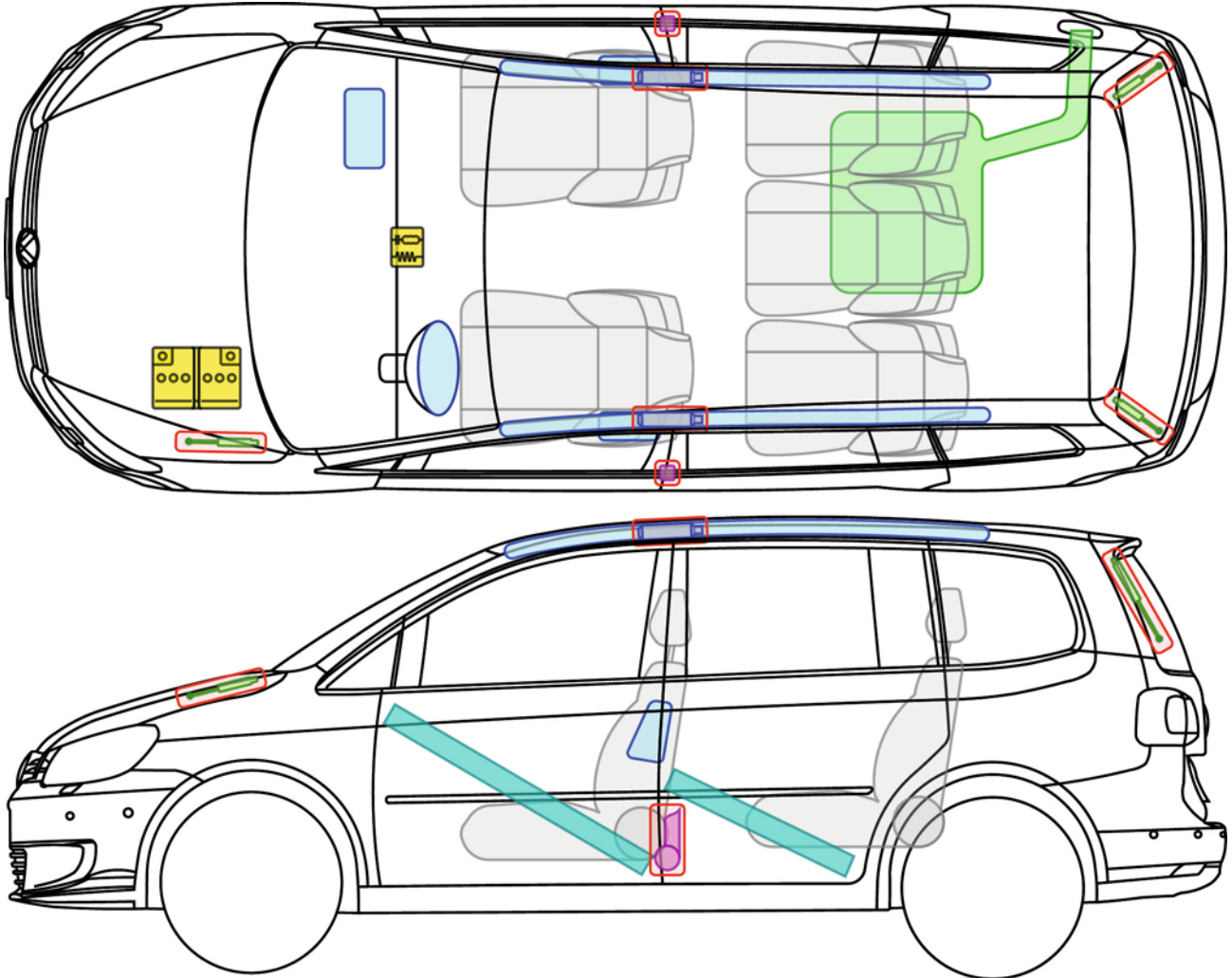



Touran

(5-Sitzer, ab 2010)



Legende

	Airbag		Karosserie-Verstärkung		Steuergerät	
	Gas-generator				12 V-Batterie	
	Gurtstraffer		Gasdruck-dämpfer		Kraftstofftank	







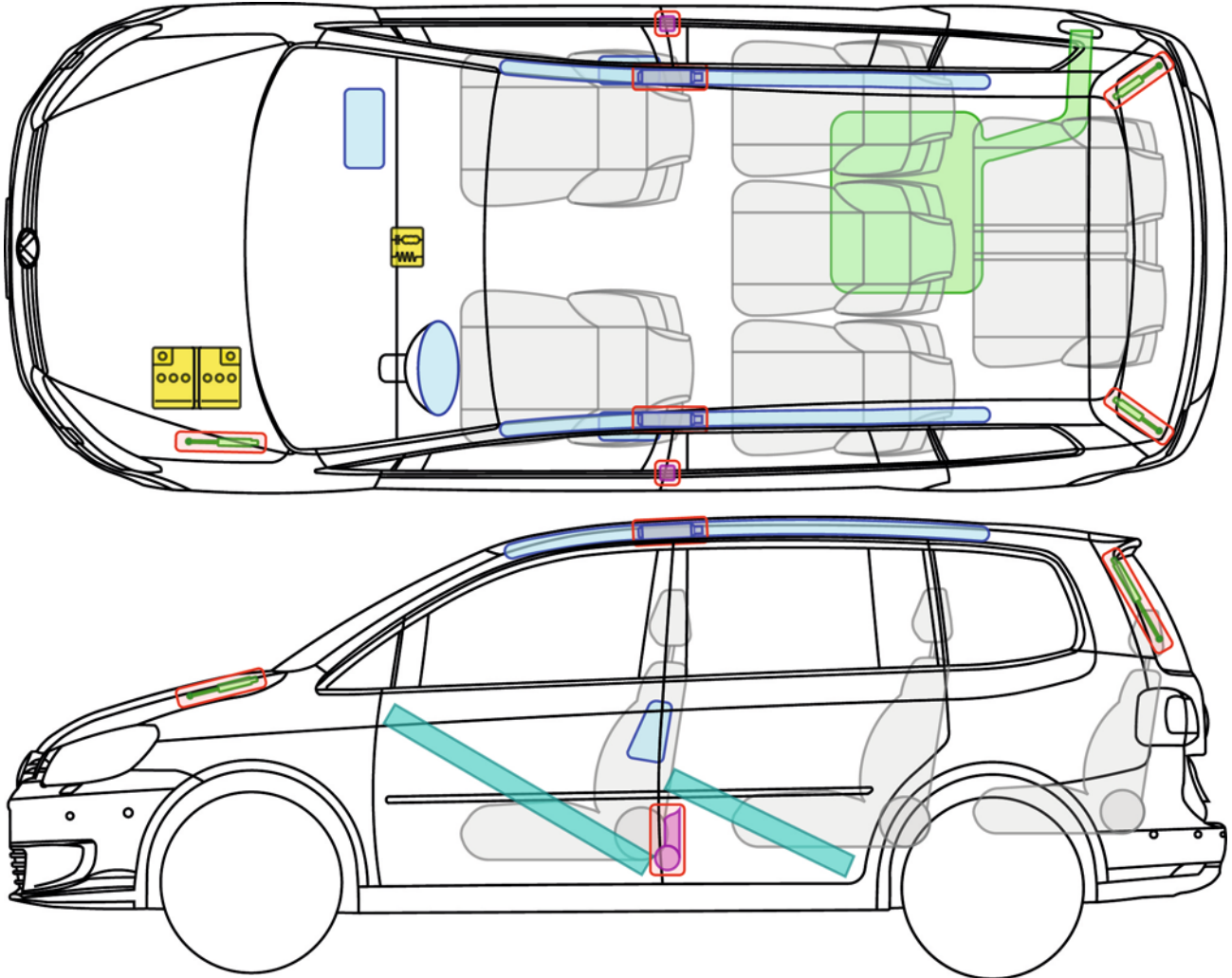



Touran

(7-Sitzer, ab 2010)



Legende

	Airbag		Karosserie-Verstärkung		Steuergerät	
	Gas-generator				12 V-Batterie	
	Gurtstraffer		Gasdruck-dämpfer		Kraftstofftank	



Touran

(5-Sitzer EcoFuel, ab 2010)

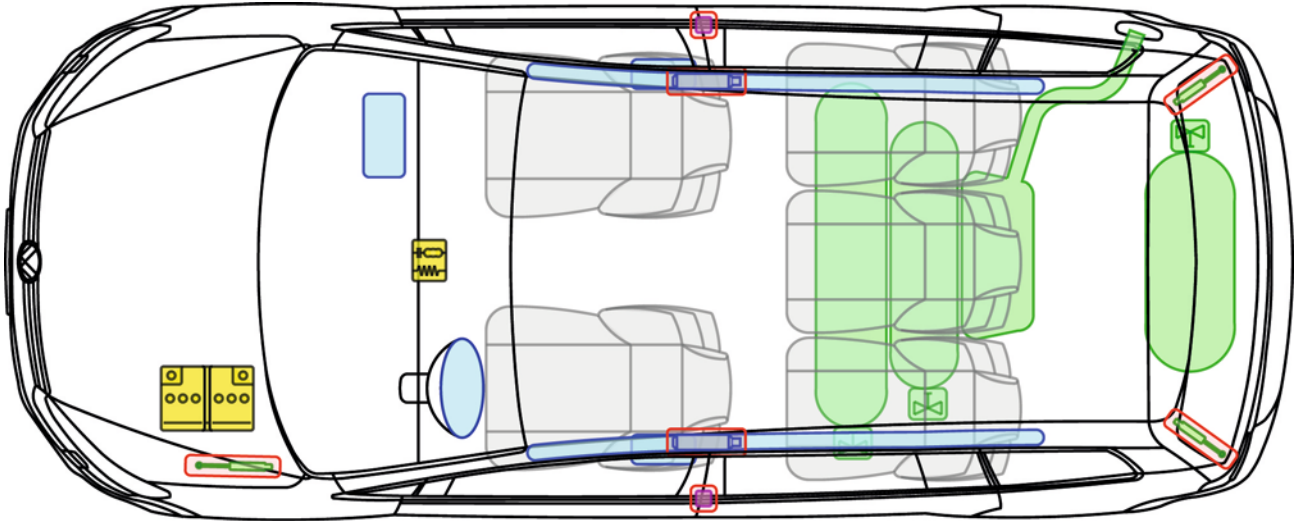





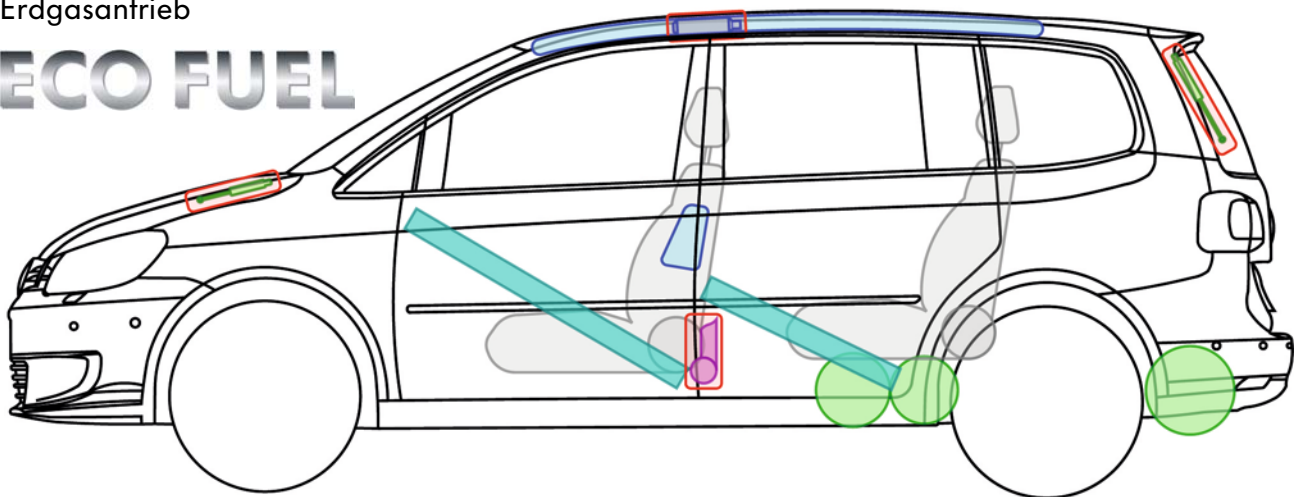



Erdgasantrieb

ECO FUEL

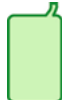

Legende

	Airbag		Karosserie-Verstärkung		Steuergerät		Gastank
	Gas-generator				12 V-Batterie		Sicherheits-ventil
	Gurtstraffer		Gasdruck-dämpfer		Kraftstofftank		



Hinweise zur Erdgasanlage

Gastanks manuell absperren (bei Gasgeruch bzw. Austritt von Erdgas)

1. Zugang zu den Erdgastanks

- Der Zugang zu den Tanks erfolgt vom Unterboden aus.
- Die Gastanks sind durch eine Kunststoffabdeckung verkleidet. Um an die Erdgastanks zu gelangen, muss diese Abdeckung mit geeigneten Mitteln entfernt werden, ohne die darunter liegenden Bauteile der Gasanlage zu beschädigen.

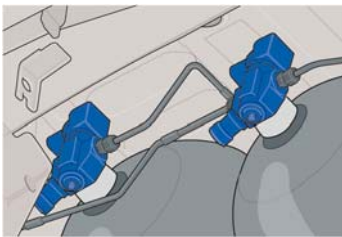

elektromagnetische Absperrventile an den Gastanks

2. Absperrhähne lokalisieren

- Jeder Gastank besitzt ein eigenes Flaschenventil mit einem manuellen Absperrhahn.
- Falls einsatzbedingt erforderlich muss jeder Gastank separat abgesperrt werden.



manueller Absperrhahn seitlich am Flaschenventil (bis 2008).

3. Gastank von Hand schließen

- Falls einsatzbedingt erforderlich muss jeder Gastank separat abgesperrt werden.
- Mit einem 5er-Maul- bzw. Ringschlüssel lässt sich das manuelle Absperrventil am Vierkant durch Drehen im Uhrzeigersinn bis zum Anschlag des Ventils verschließen.



manueller Absperrhahn am Fuß des Flaschenventils.



Touran

(7-Sitzer EcoFuel, ab 2010)

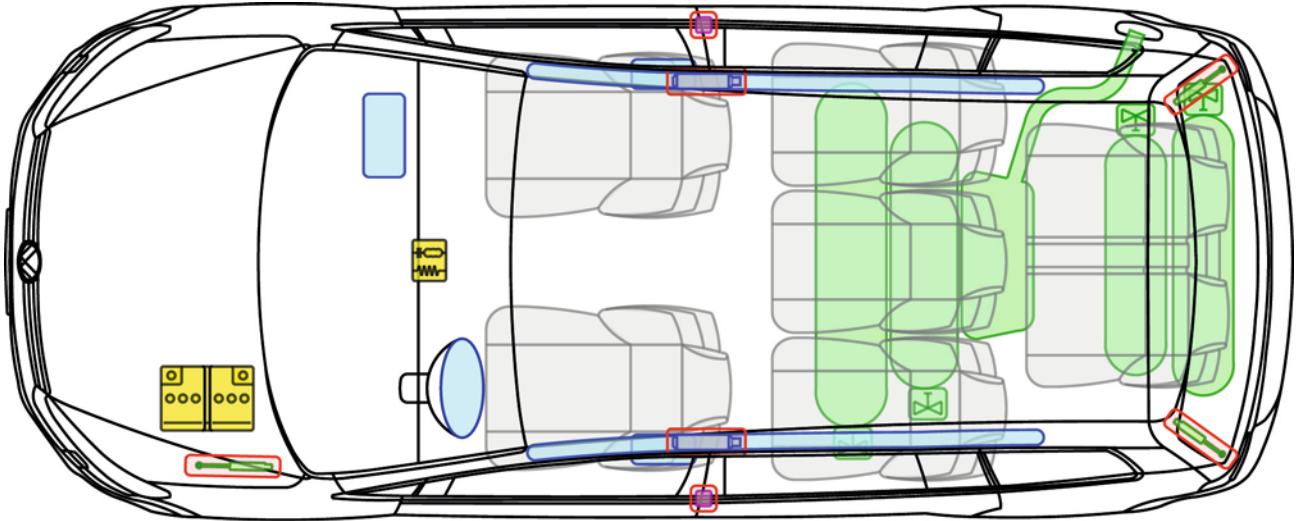





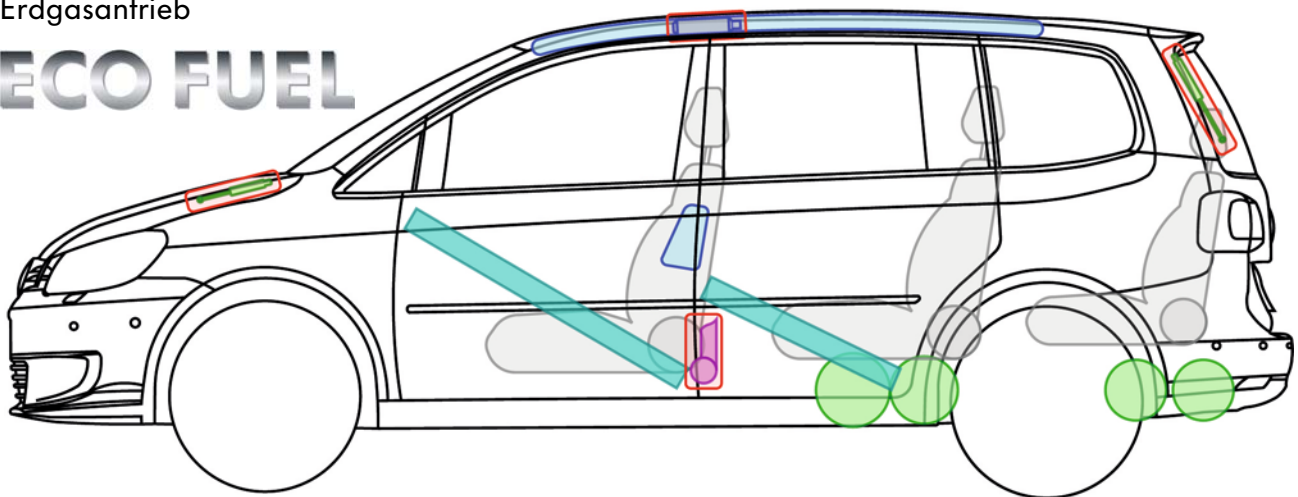





Erdgasantrieb

ECO FUEL



Legende

	Airbag		Karosserie-Verstärkung		Steuergerät		Gastank
	Gas-generator				12 V-Batterie		Sicherheits-ventil
	Gurtstraffer		Gasdruck-dämpfer		Kraftstofftank		



Hinweise zur Erdgasanlage

Gastanks manuell absperren (bei Gasgeruch bzw. Austritt von Erdgas)

1. Zugang zu den Erdgastanks

- Der Zugang zu den Tanks erfolgt vom Unterboden aus.
- Die Gastanks sind durch eine Kunststoffabdeckung verkleidet. Um an die Erdgastanks zu gelangen, muss diese Abdeckung mit geeigneten Mitteln entfernt werden, ohne die darunter liegenden Bauteile der Gasanlage zu beschädigen.

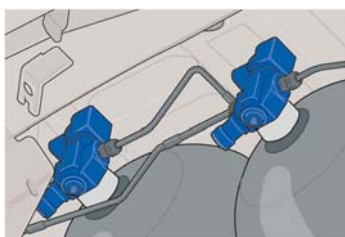

elektromagnetische Absperrventile an den Gastanks

2. Absperrhähne lokalisieren

- Jeder Gastank besitzt ein eigenes Flaschenventil mit einem manuellen Absperrhahn.
- Falls einsatzbedingt erforderlich muss jeder Gastank separat abgesperrt werden.

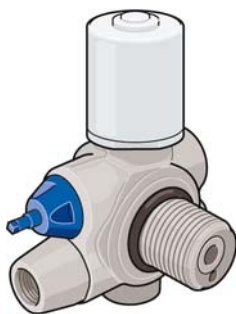

manueller Absperrhahn seitlich am Flaschenventil (bis 2008).

3. Gastank von Hand schließen

- Falls einsatzbedingt erforderlich muss jeder Gastank separat abgesperrt werden.
- Mit einem 5er-Maul- bzw. Ringschlüssel lässt sich das manuelle Absperrventil am Vierkant durch Drehen im Uhrzeigersinn bis zum Anschlag des Ventils verschließen.



manueller Absperrhahn am Fuß des Flaschenventils.



Transporter LT2



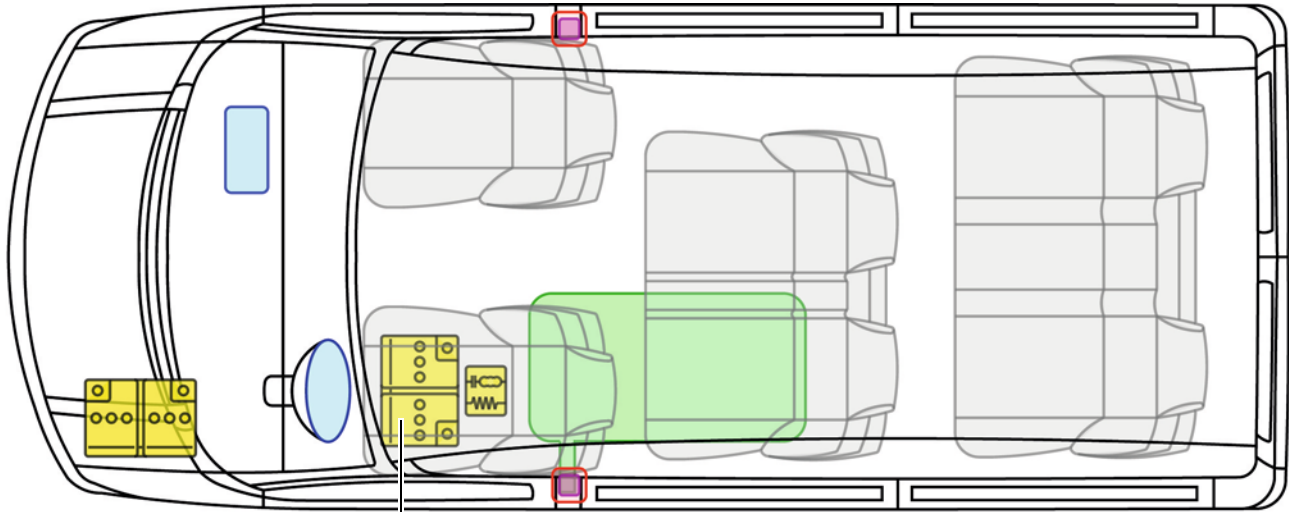

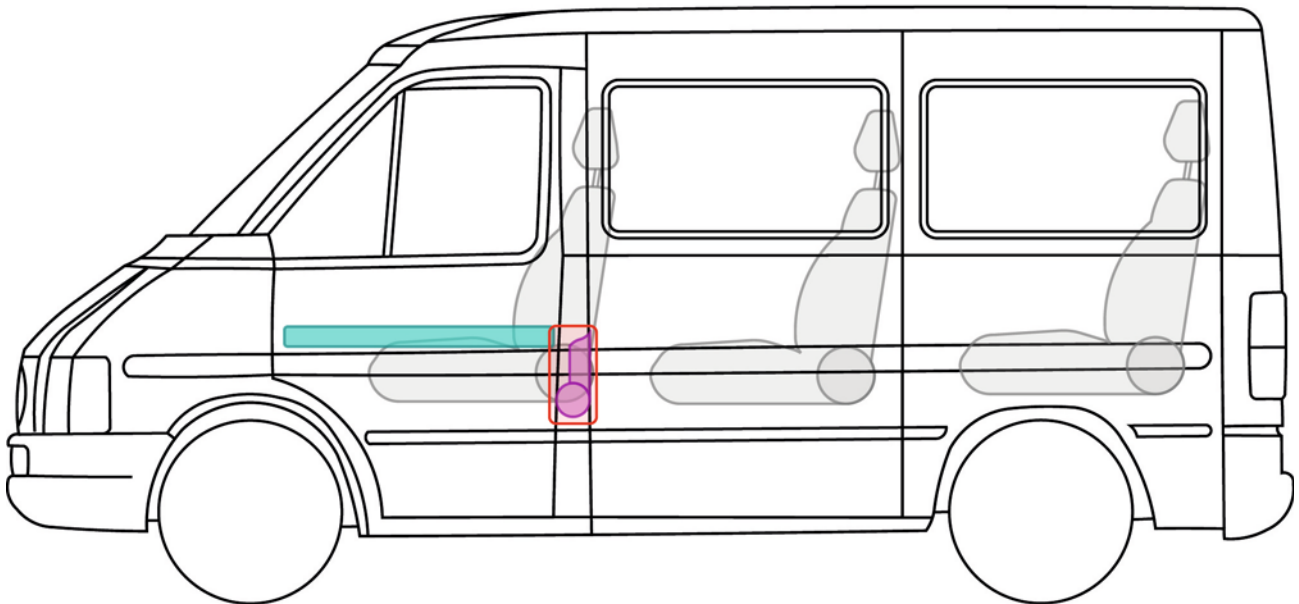

(1996 - 2006)



ausstattungsabhängig zusätzliche Batterie unter dem Fahrersitz

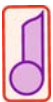

Legende

	Airbag		Karosserie-Verstärkung		Steuergerät
					12V-Batterie
	Gurtstraffer				Kraftstofftank







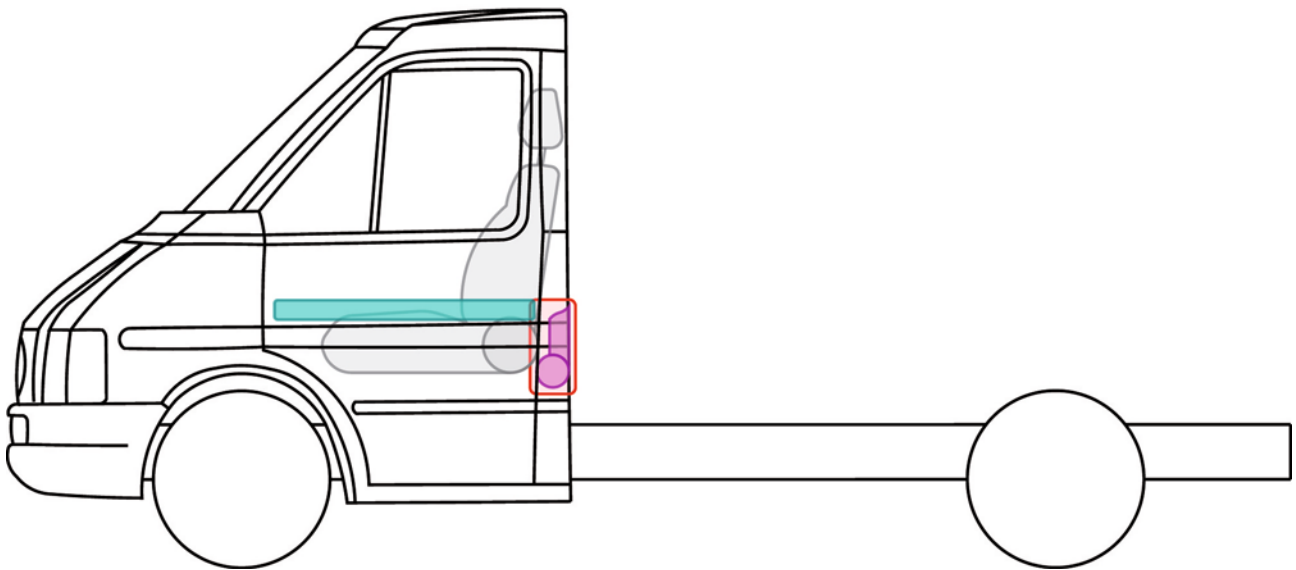
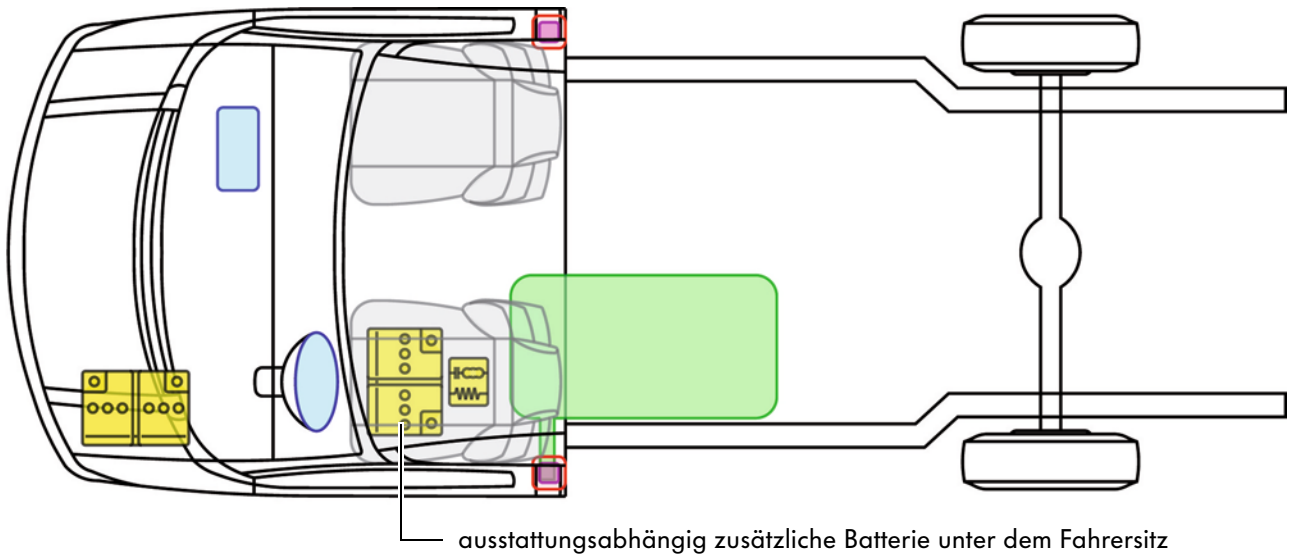

Transporter LT2 Fahrgestell

(2-Türer, 1996 - 2006)



Legende

	Airbag		Karosserie-Verstärkung		Steuergerät	
					12V-Batterie	
	Gurtstraffer				Kraftstofftank	







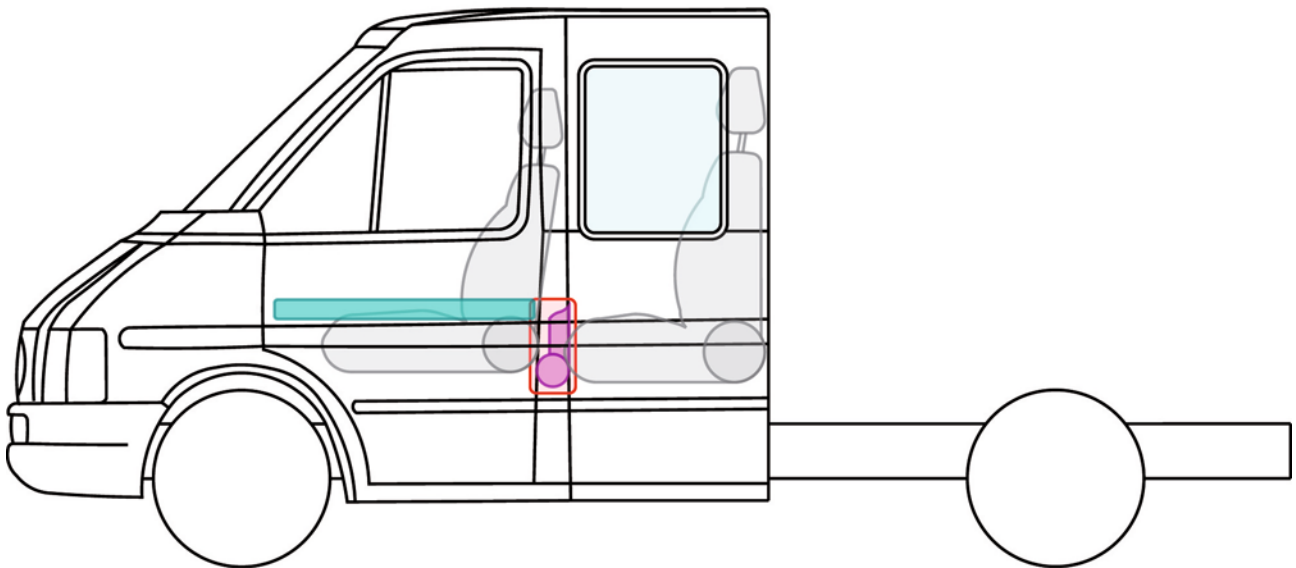
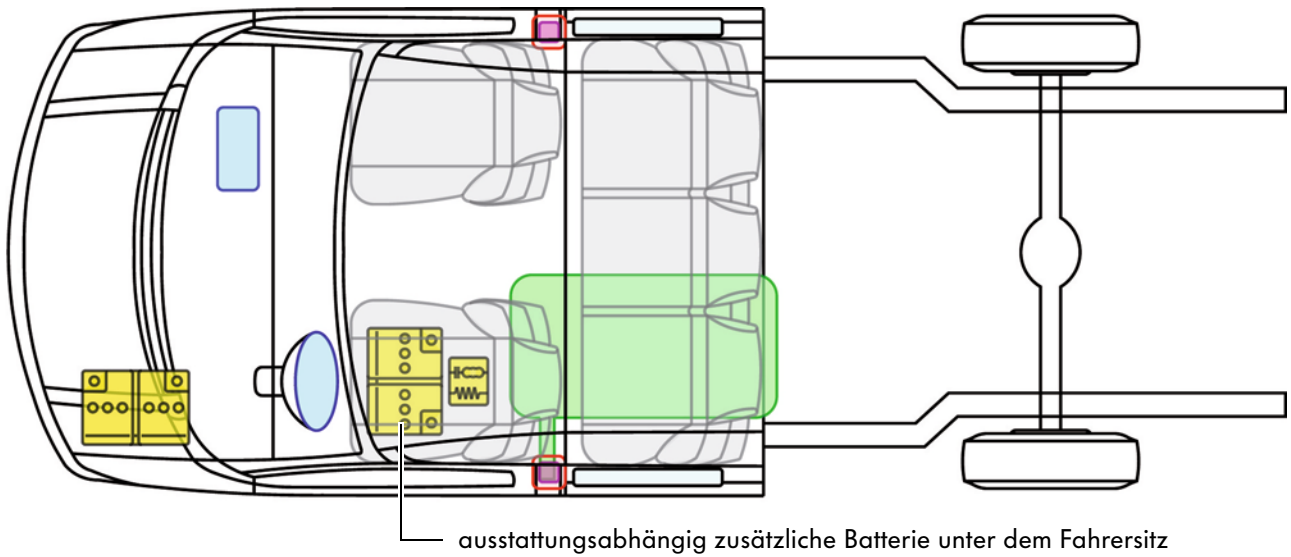

Transporter LT2 Fahrgestell

(4-Türer, 1996 - 2006)



Legende





	Airbag		Karosserie-Verstärkung		Steuergerät
					12V-Batterie
	Gurtstraffer				Kraftstofftank

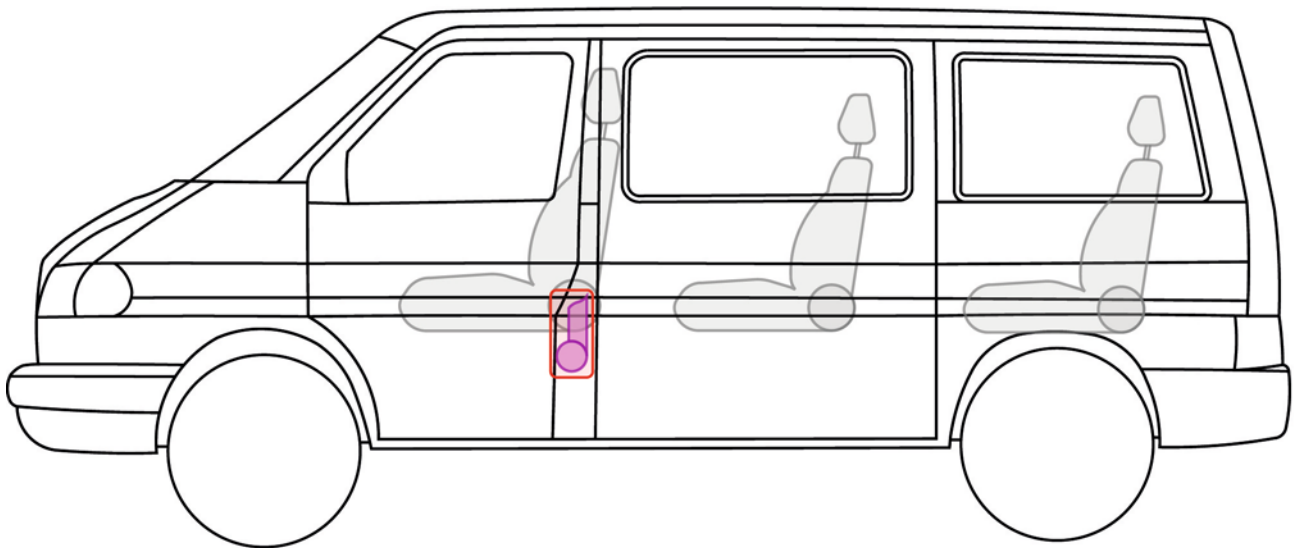
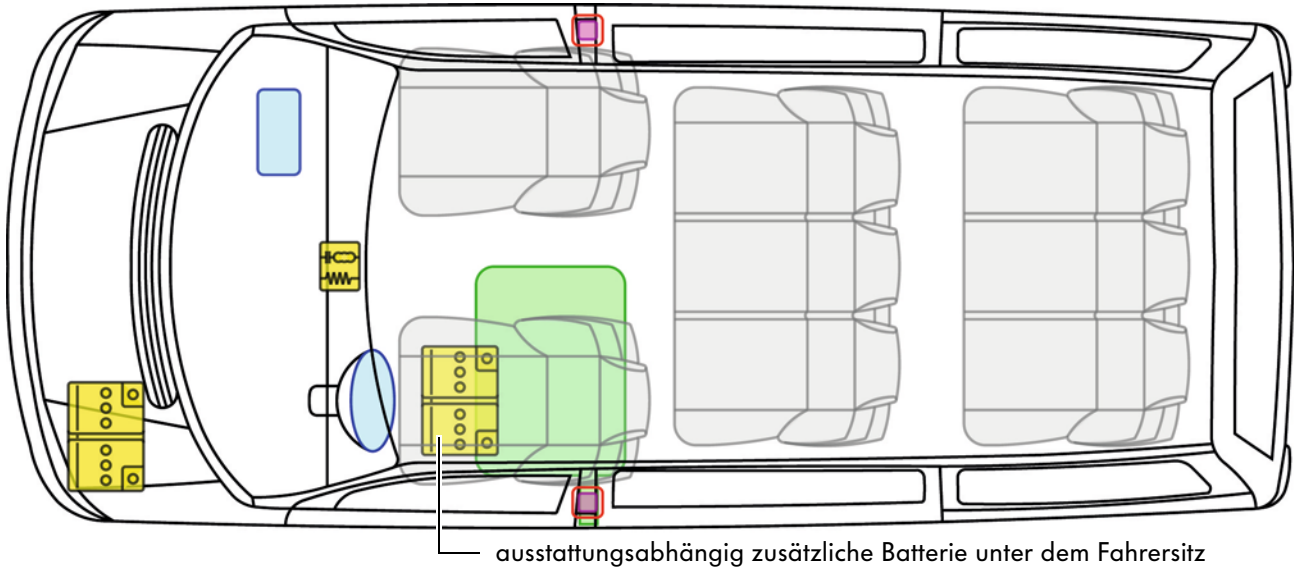

Transporter T4 (1991 - 2003)

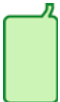

Legende

	Airbag		Karosserie-Verstärkung		Steuergerät	
					12V-Batterie	
	Gurtstraffer				Kraftstofftank	





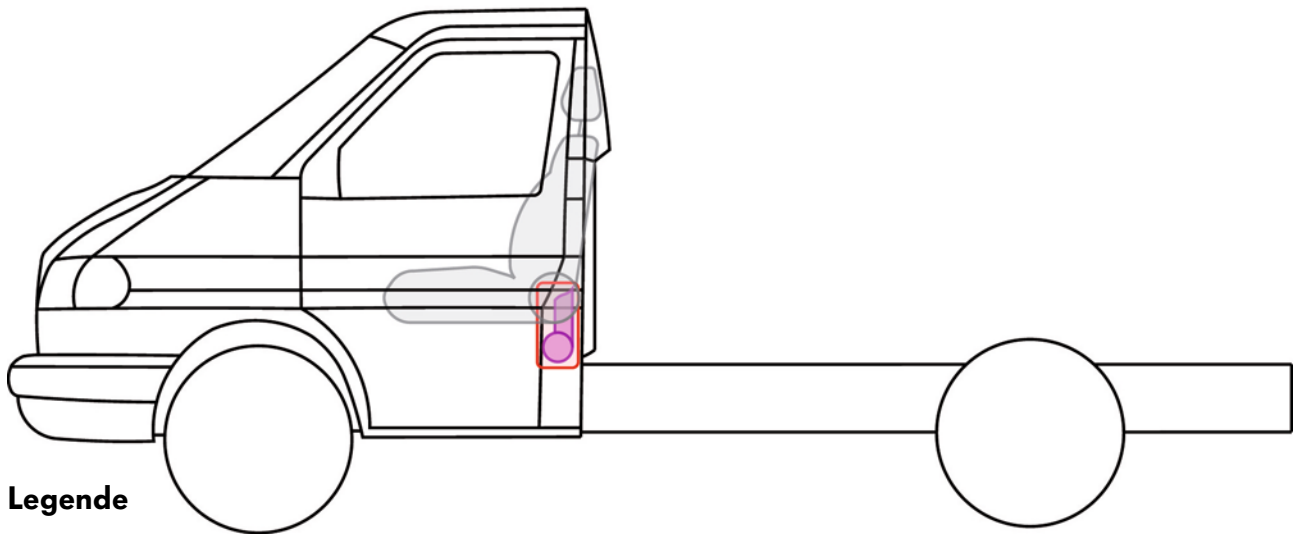
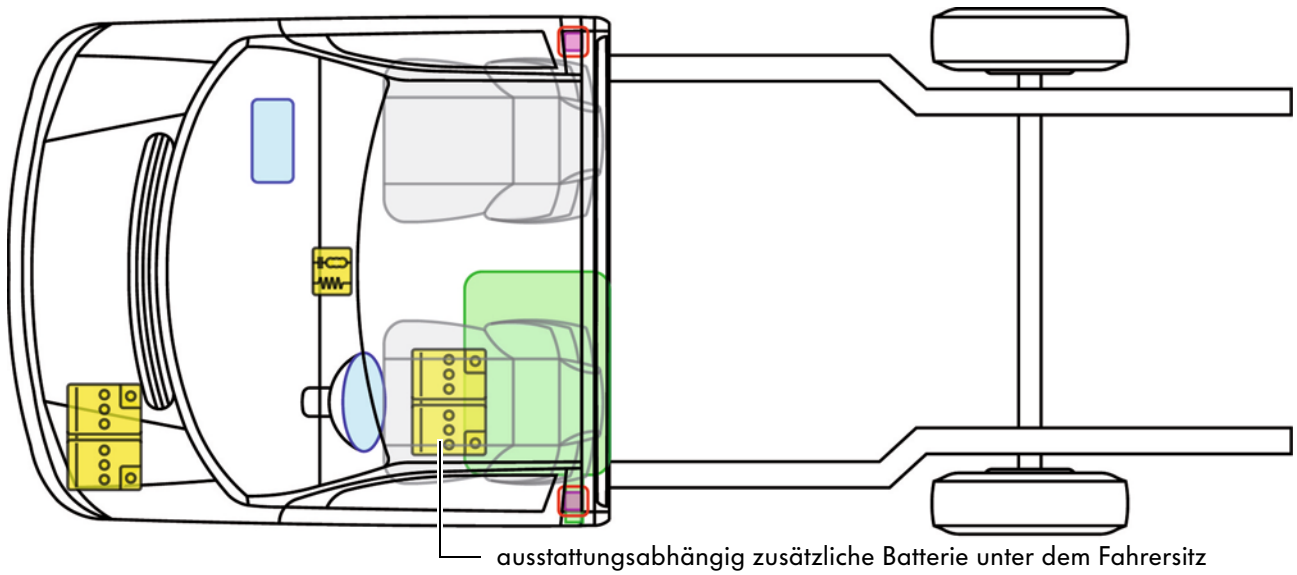

Transporter T4 Fahrgestell

(2-Türer, 1991 - 2003)



Legende

	Airbag		Steuergerät
			12V-Batterie
	Gurtstraffer		Kraftstofftank





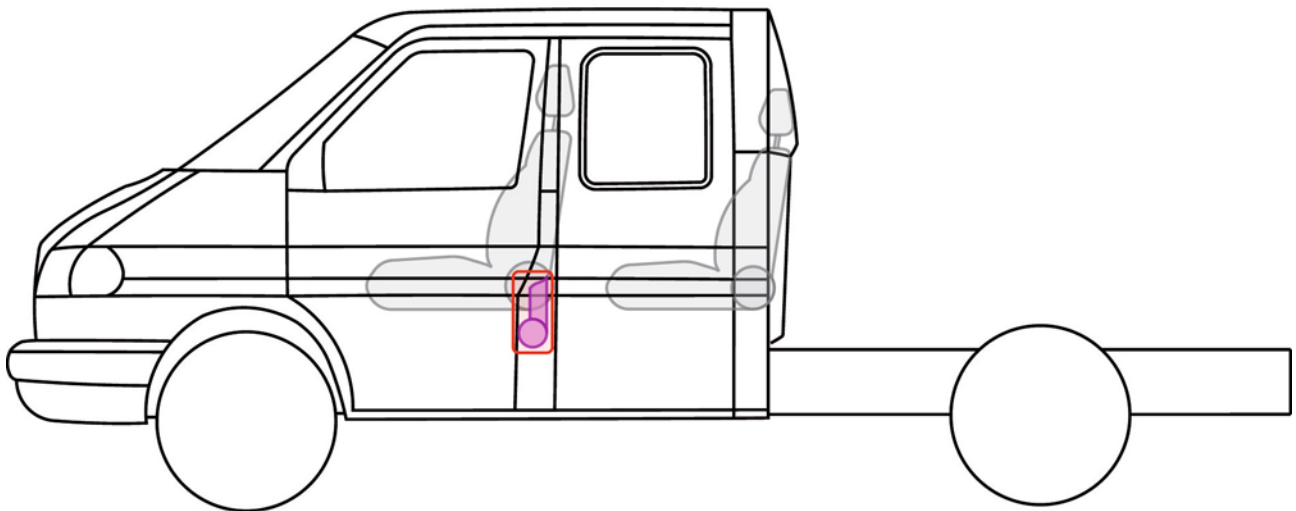
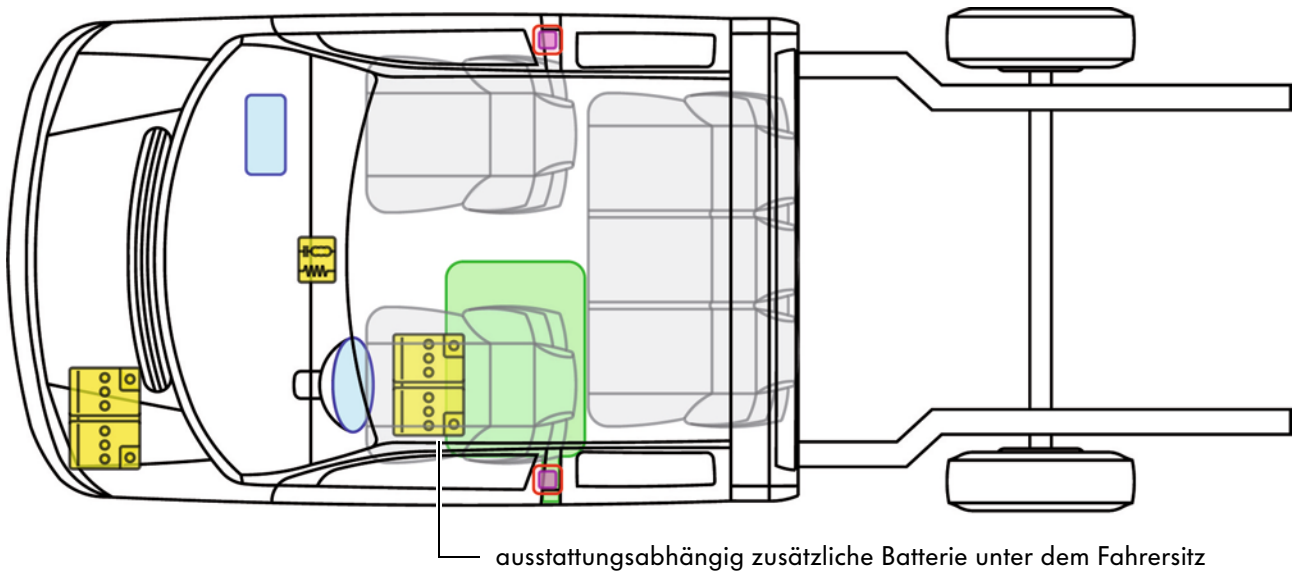

Transporter T4 Fahrgestell

(4-Türer, 1991 - 2003)



Legende

	Airbag		Steuergerät
			12V-Batterie
	Gurtstraffer		Kraftstofftank







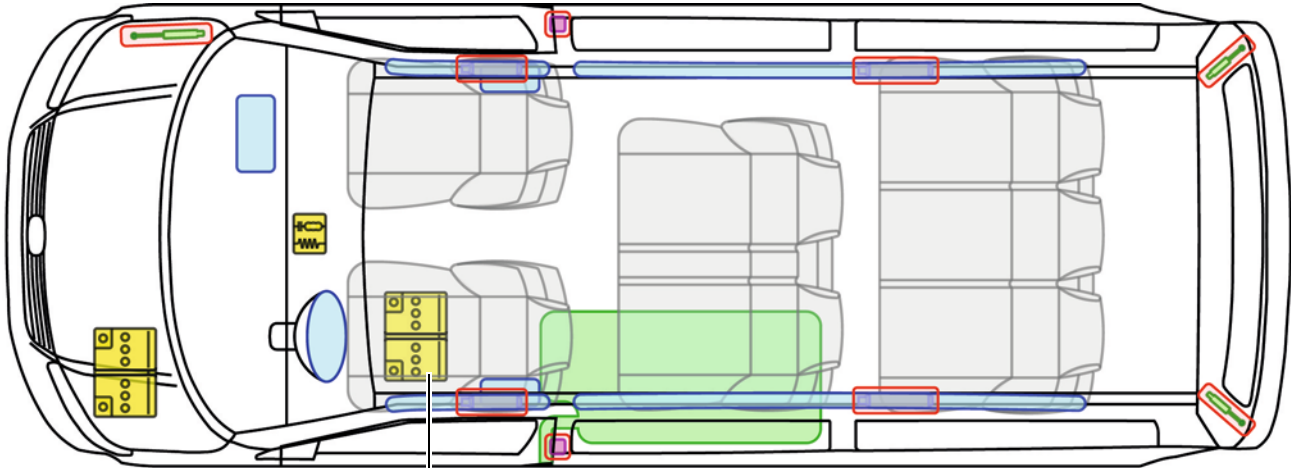



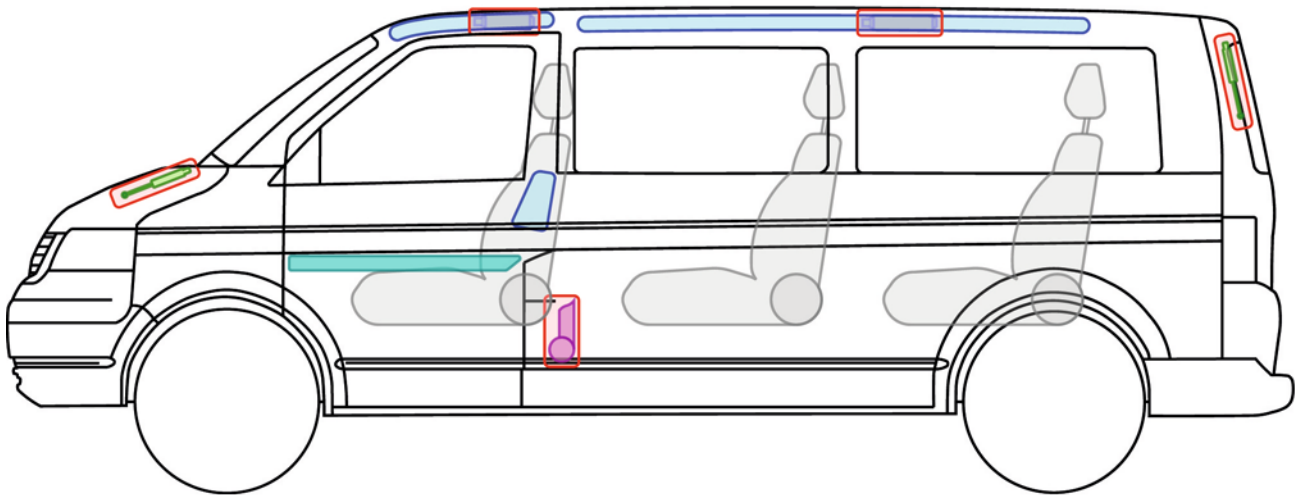

Transporter T5 (2003 - 2009)



ausstattungsabhängig zusätzliche Batterie unter dem Fahrersitz

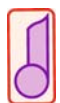

Legende

	Airbag		Karosserie-Verstärkung		Steuergerät	
	Gas-generator				12V-Batterie	
	Gurtstraffer		Gasdruck-dämpfer		Kraftstofftank	



Transporter T5 Fahrgestell



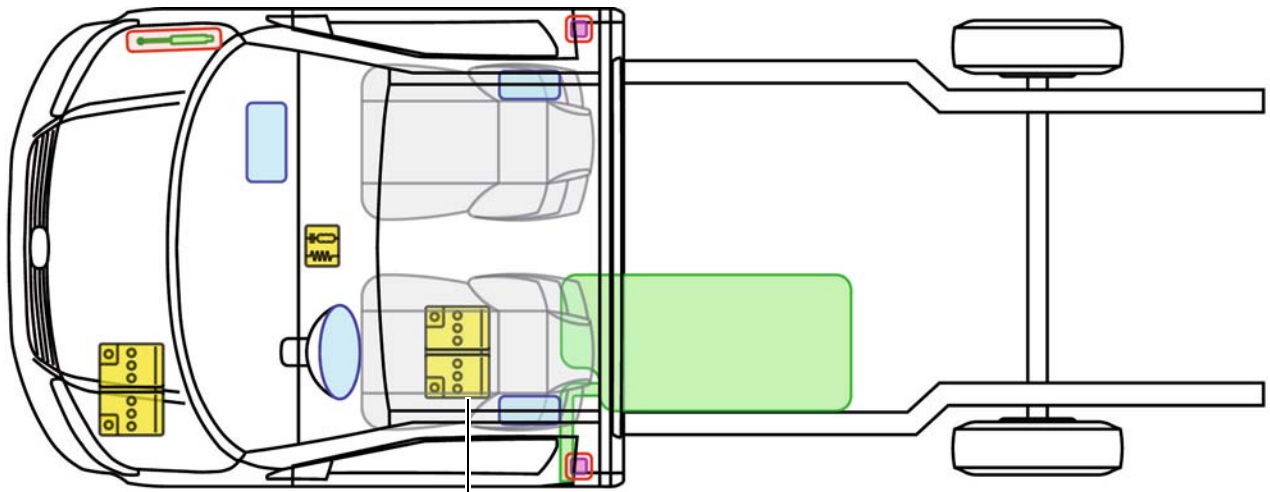

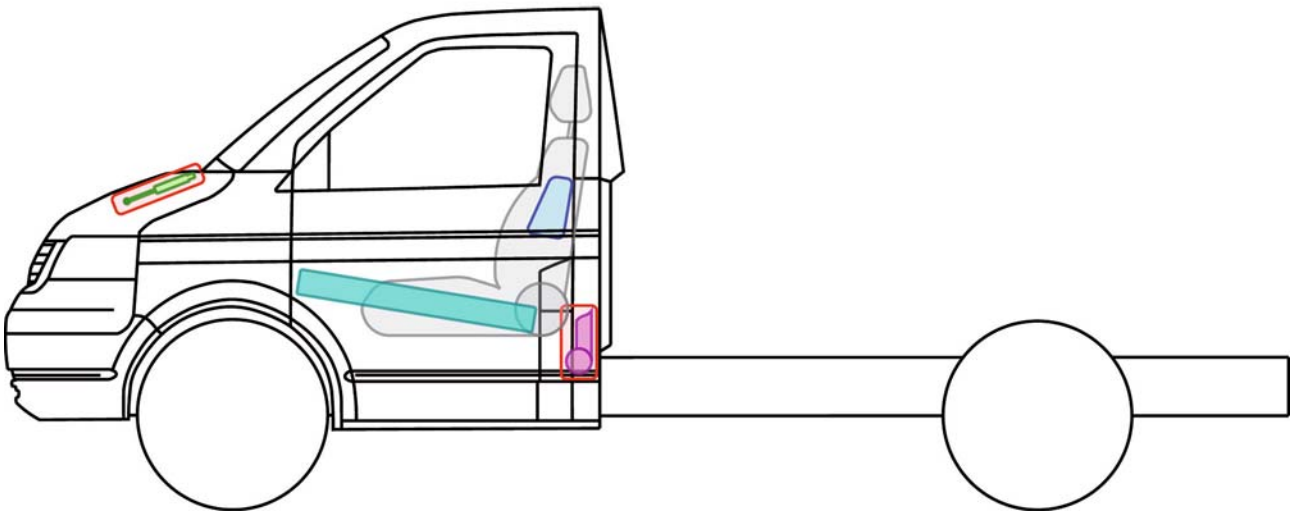

(2-Türer, 2003 - 2009)



ausstattungsabhängig zusätzliche Batterie unter dem Fahrersitz

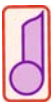

Legende

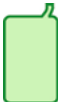
	Airbag		Karosserie-Verstärkung		Steuergerät
					12V-Batterie
	Gurtstraffer		Gasdruck-dämpfer		Kraftstofftank



Transporter T5 Fahrgestell



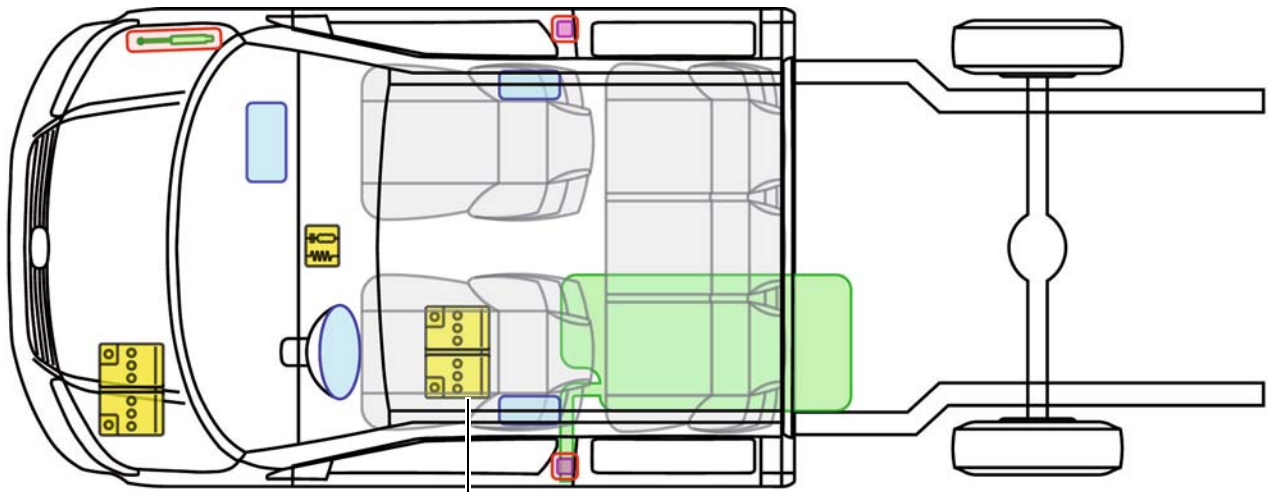

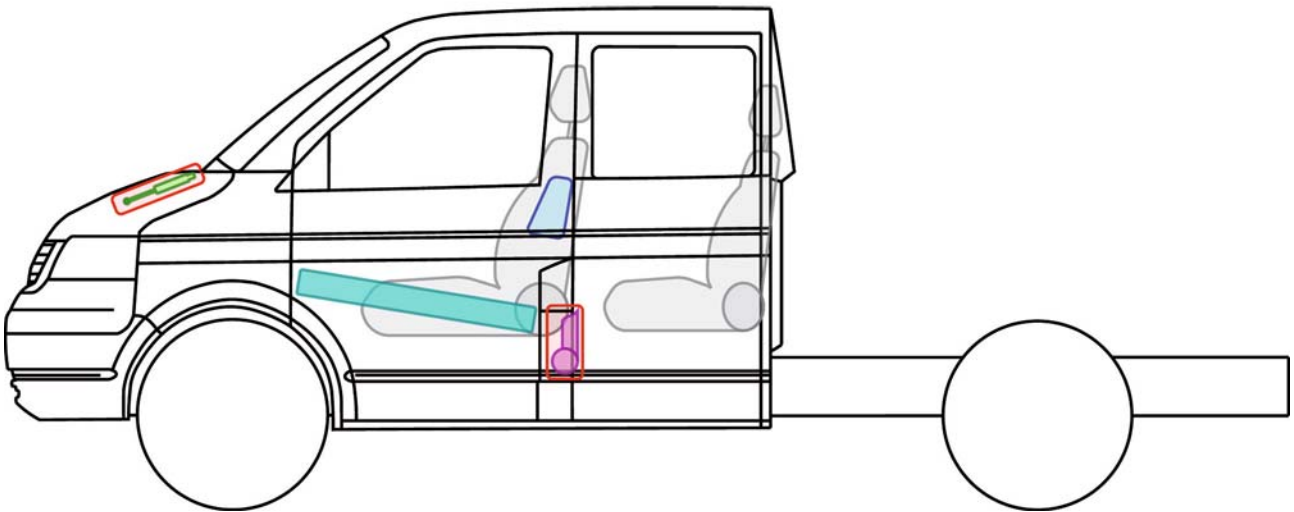

(4-Türer, 2003 - 2009)



ausstattungsabhängig zusätzliche Batterie unter dem Fahrersitz

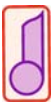

Legende

	Airbag		Karosserie-Verstärkung		Steuergerät
					12V-Batterie
	Gurtstraffer		Gasdruck-dämpfer		Kraftstofftank







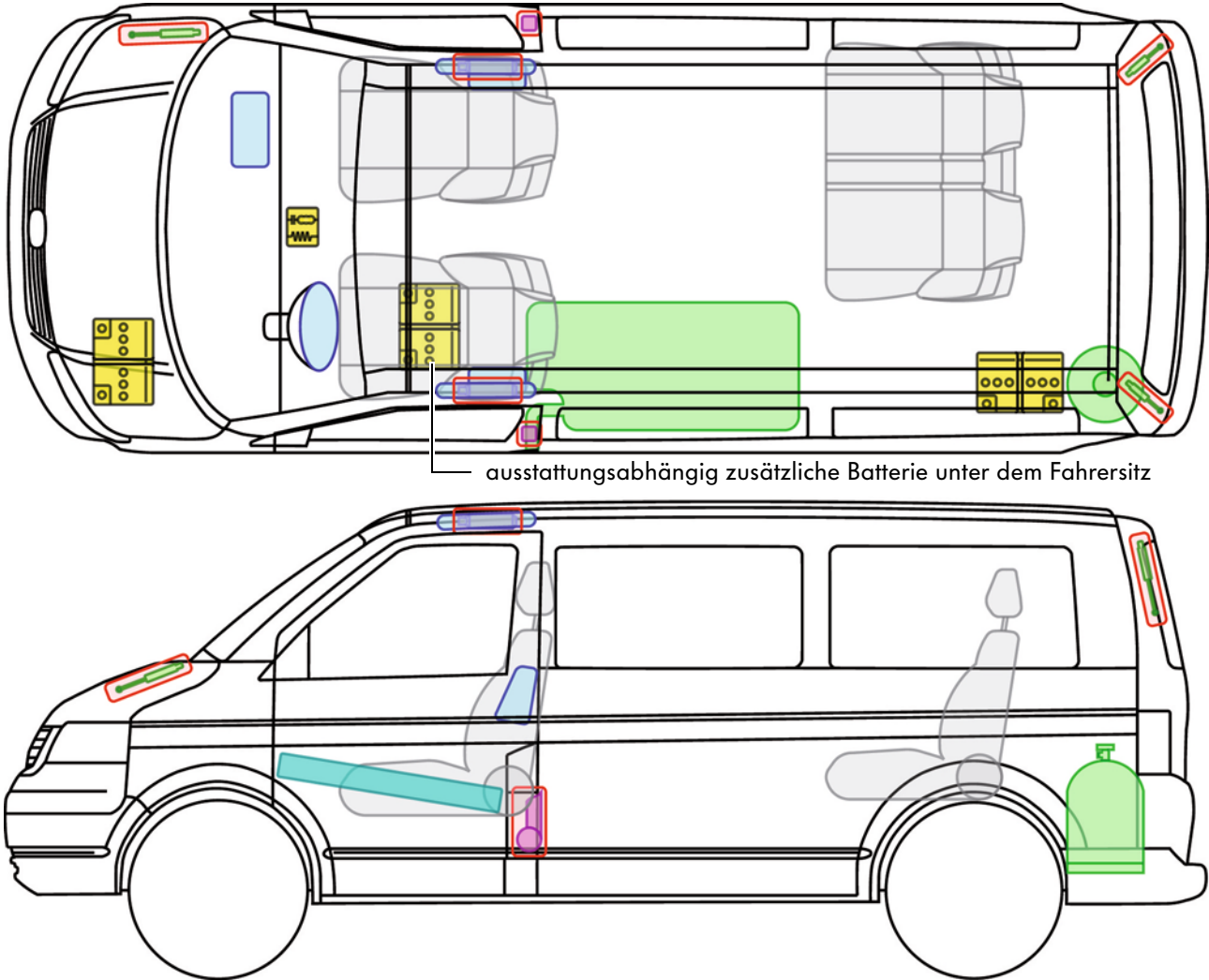



Transporter T5 California

(2003 - 2009)

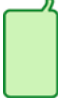

Legende

	Airbag		Karosserie-Verstärkung		Steuergerät		Gastank
	Gas-generator				12V-Batterie		
	Gurtstraffer		Gasdruck-dämpfer		Kraftstofftank		





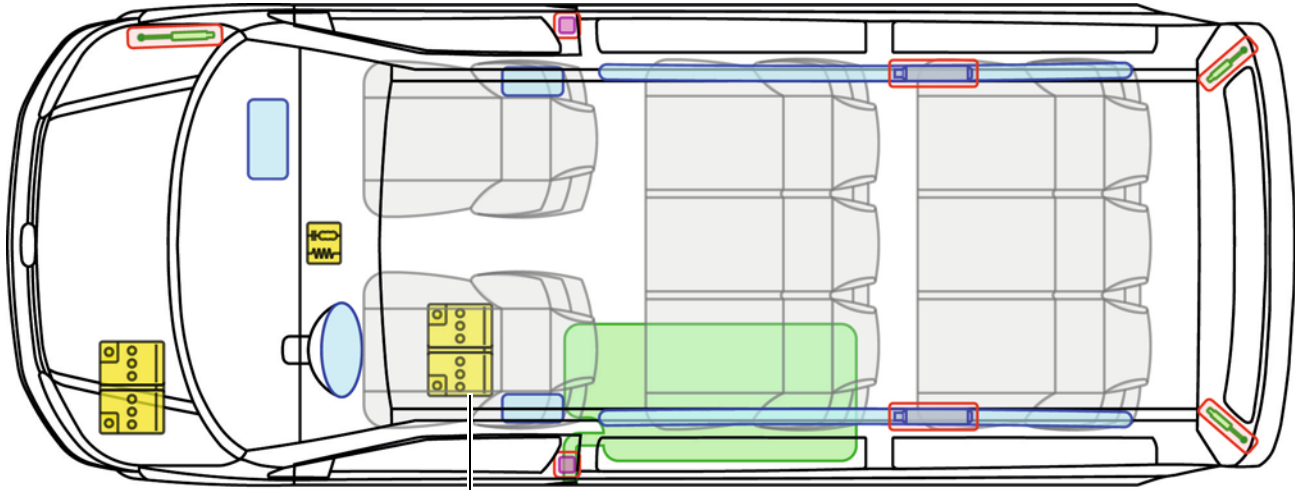

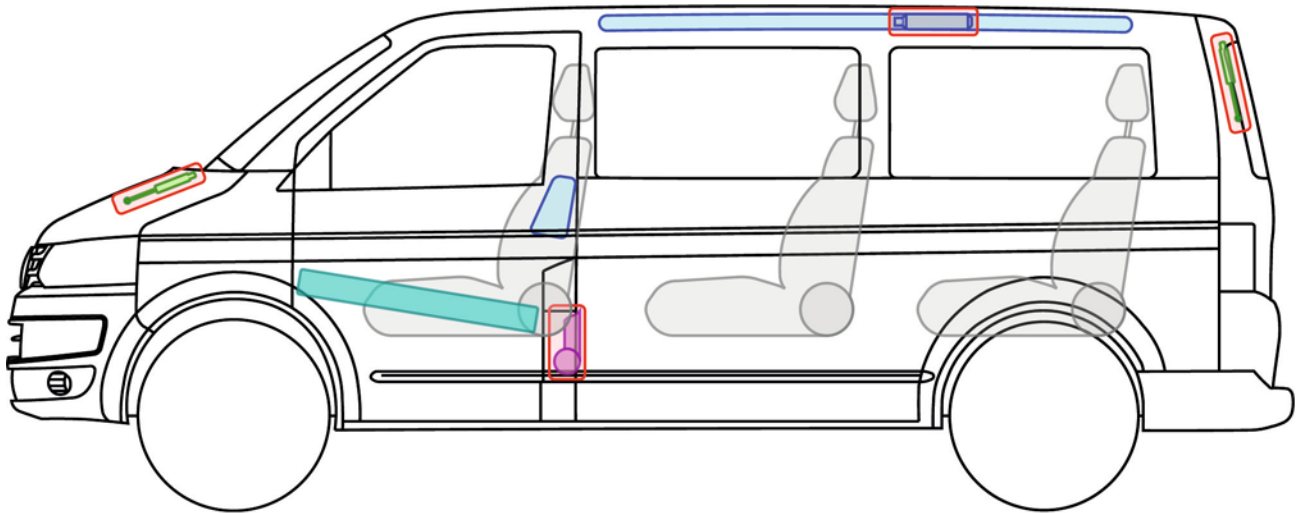

Transporter T5 (ab 2010)



ausstattungsabhängig zusätzliche Batterie unter dem Fahrersitz

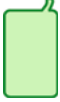

Legende

	Airbag		Karosserie-Verstärkung		Steuergerät
	Gas-generator				12V-Batterie
	Gurtstraffer		Gasdruck-dämpfer		Kraftstofftank



Transporter T5 Fahrgestell



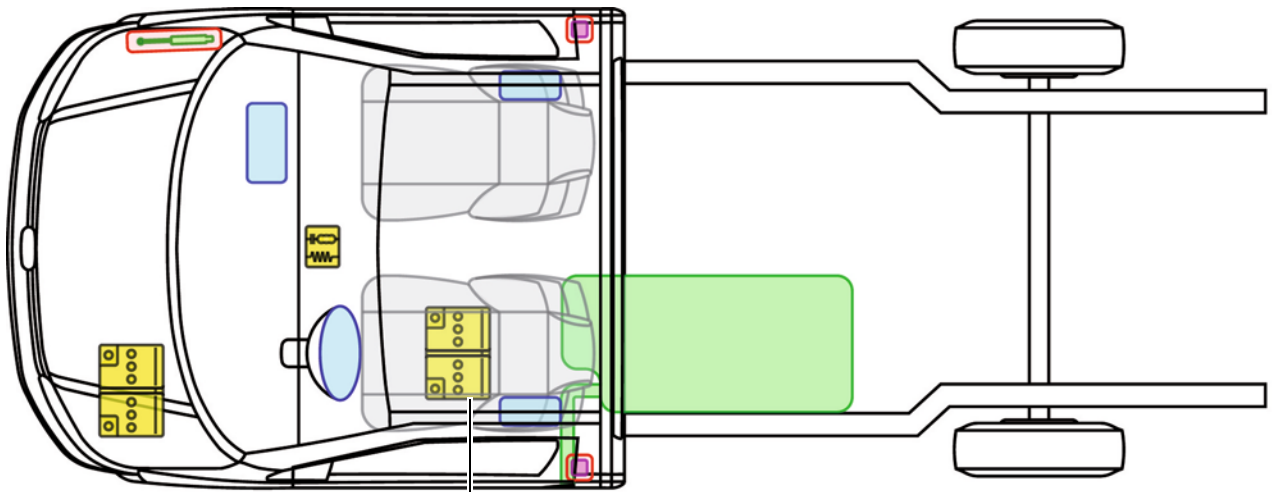

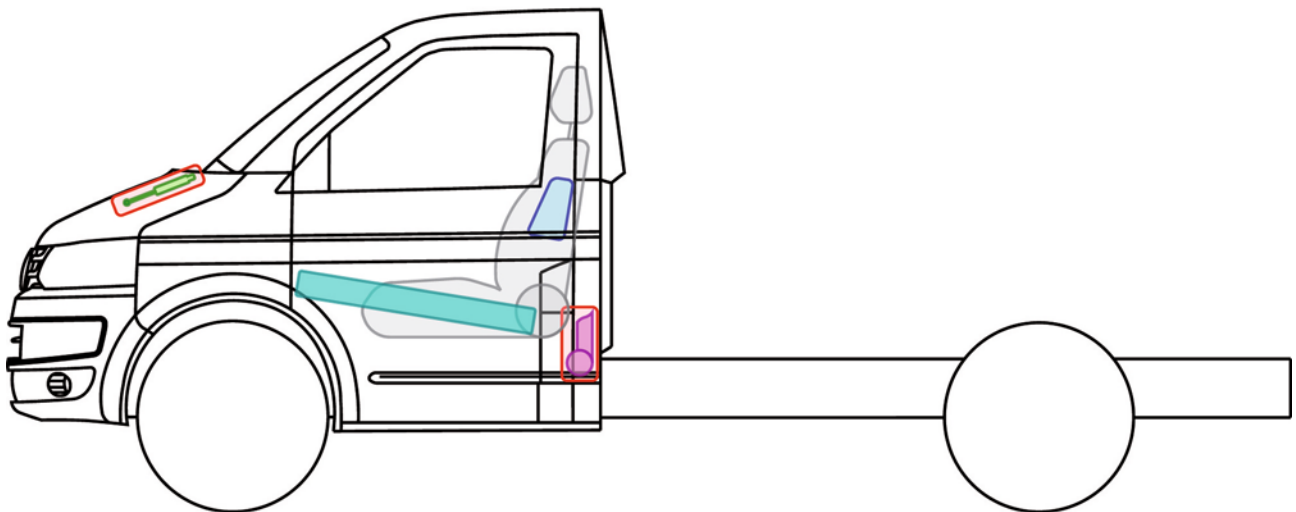

(2-Türer, ab 2010)



ausstattungsabhängig zusätzliche Batterie unter dem Fahrersitz

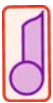

Legende

	Airbag		Karosserie-Verstärkung		Steuergerät
					12V-Batterie
	Gurtstraffer		Gasdruck-dämpfer		Kraftstofftank



Transporter T5 Fahrgestell



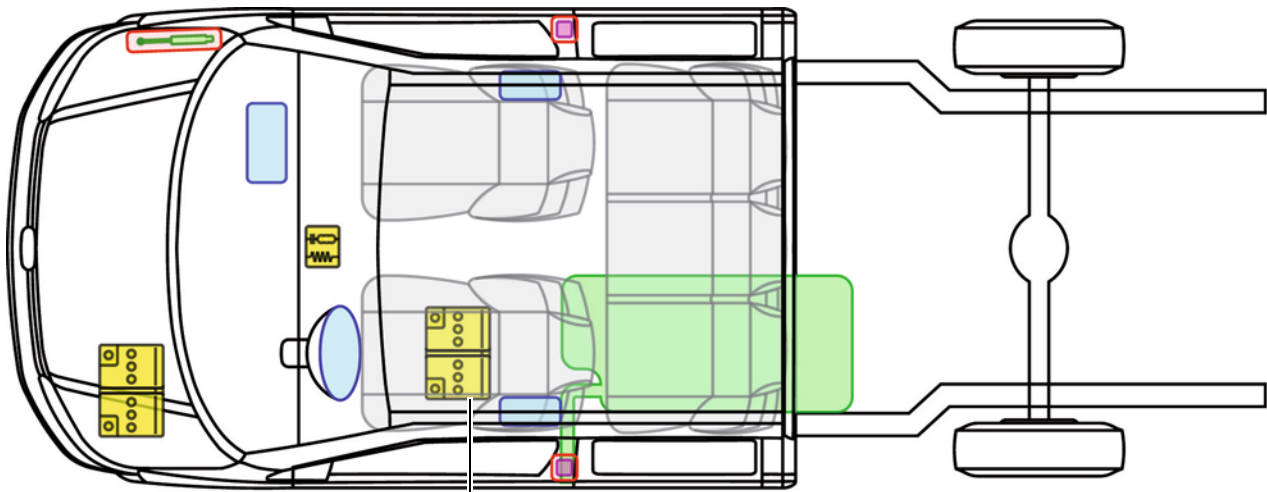

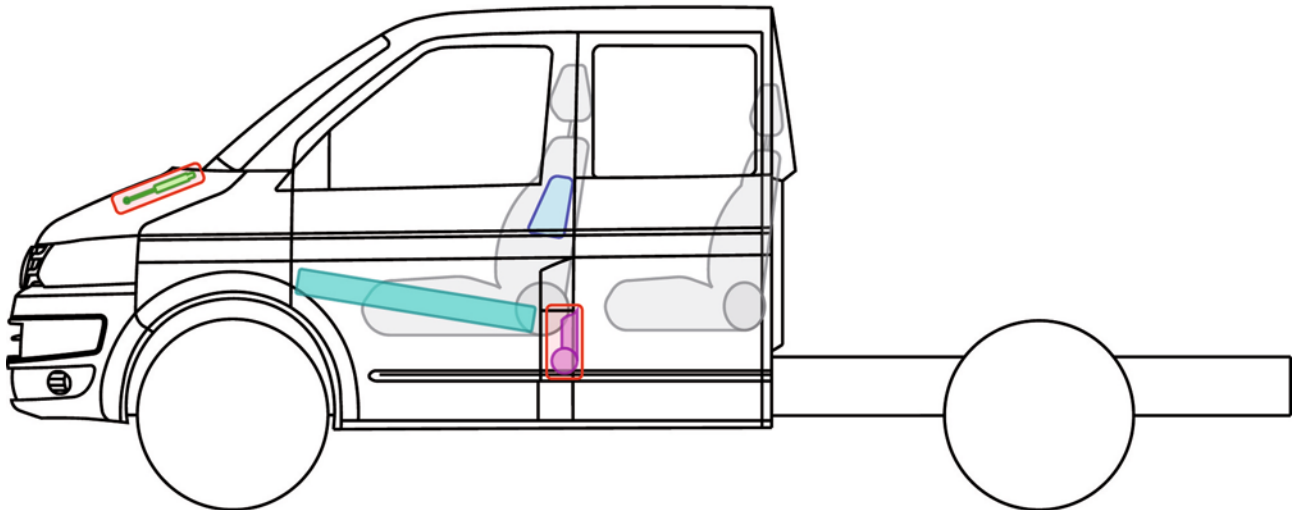

(4-Türer, ab 2010)



ausstattungsabhängig zusätzliche Batterie unter dem Fahrersitz

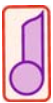

Legende

	Airbag		Karosserie-Verstärkung		Steuergerät	
					12V-Batterie	
	Gurtstraffer		Gasdruck-dämpfer		Kraftstofftank	







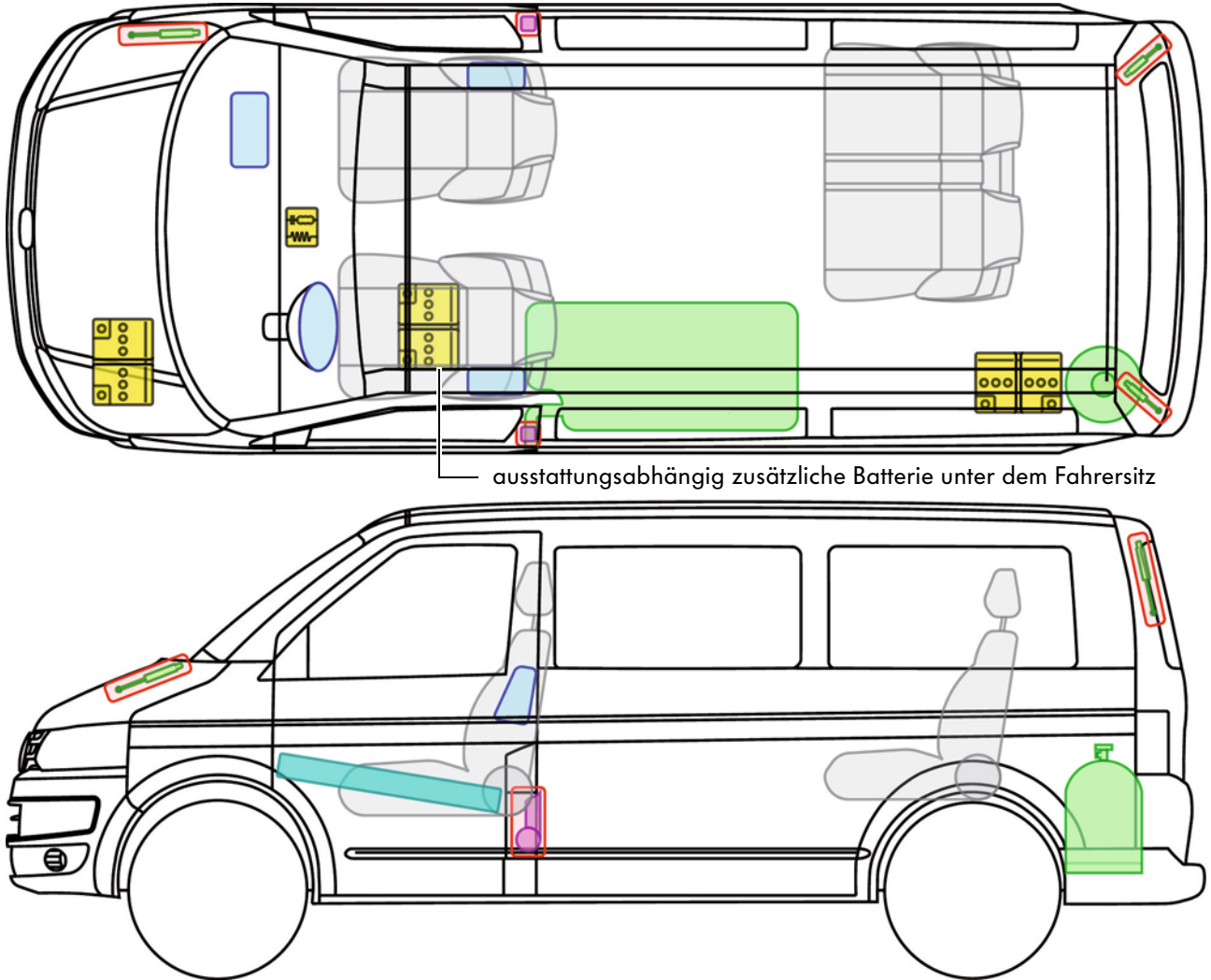

Transporter T5 California

(ab 2010)

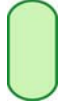

Legende

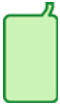



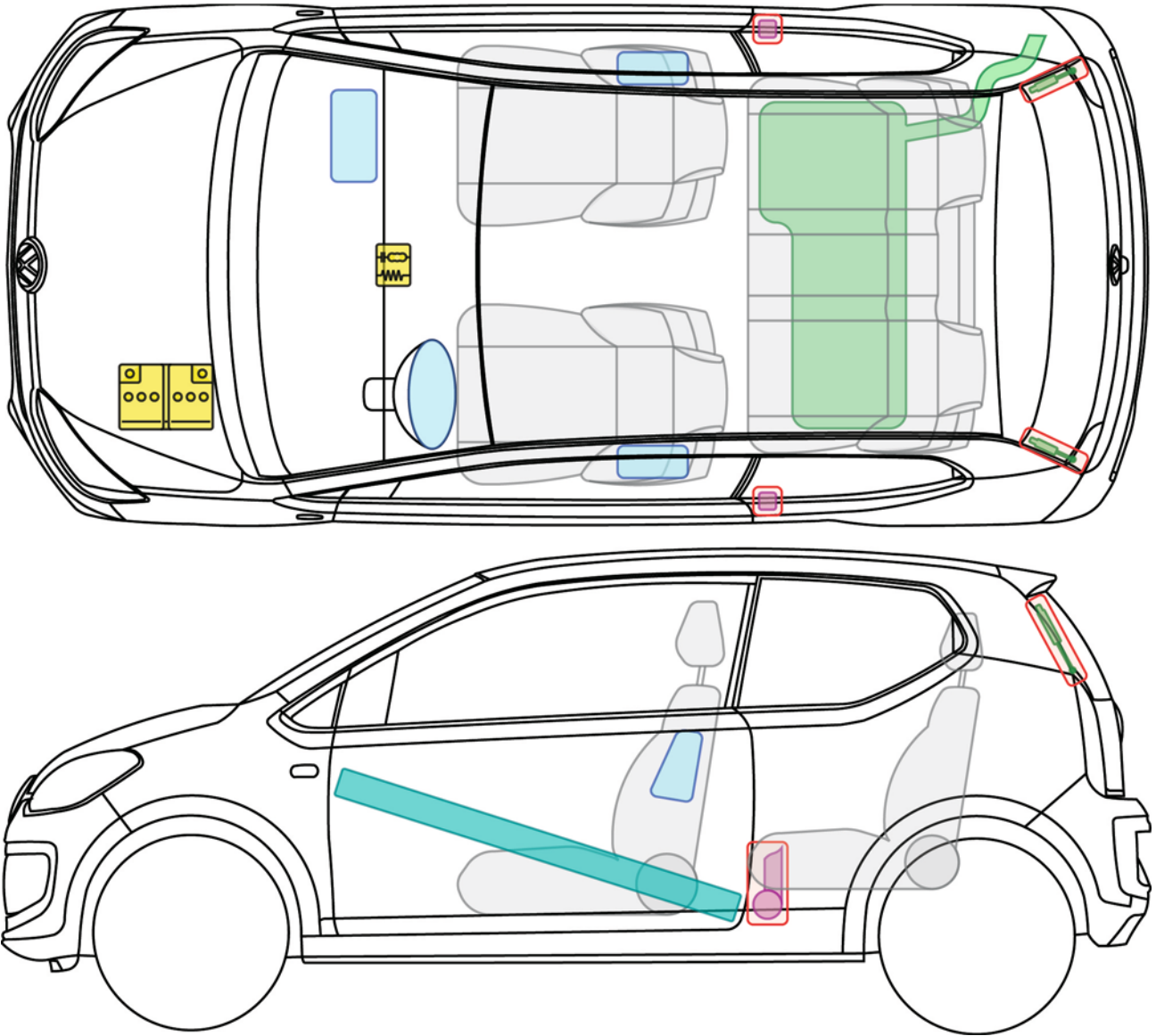

	Airbag		Karosserie-Verstärkung		Steuergerät		Gastank
					12V-Batterie		
	Gurtstraffer		Gasdruck-dämpfer		Kraftstofftank		



up!
(3-Türer, ab 2011)

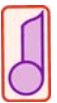

Legende





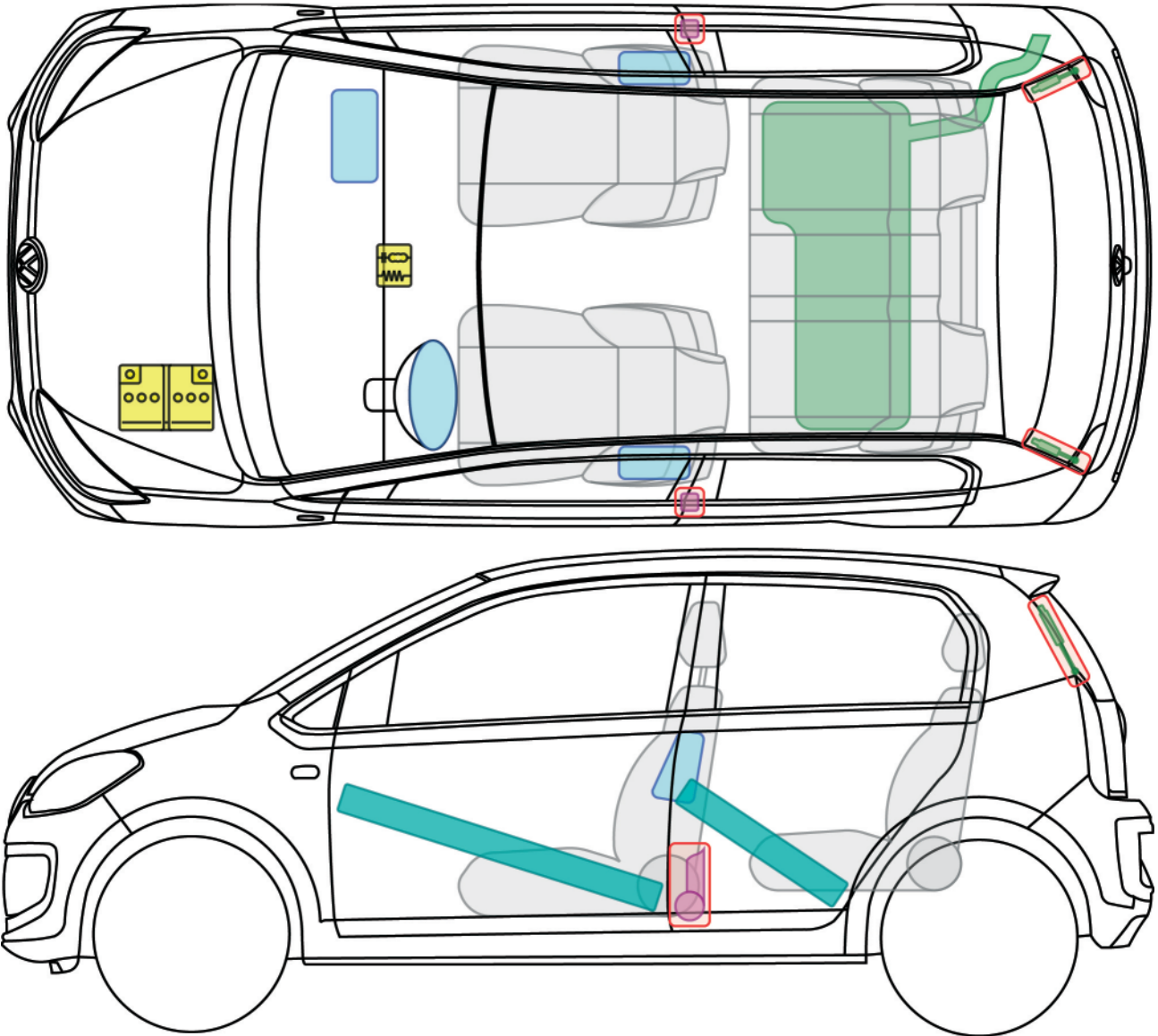

	Airbag		Karosserie-Verstärkung		Steuergerät	
					12 V-Batterie	
	Gurtstraffer		Gasdruck-dämpfer		Kraftstofftank	



up!
(5-Türer, ab 2011)



Legende

	Airbag		Karosserie-Verstärkung		Steuergerät	
					12V-Batterie	
	Gurtstraffer		Gasdruckdämpfer		Kraftstofftank	

U

up! (5-Türer, ab 2011)







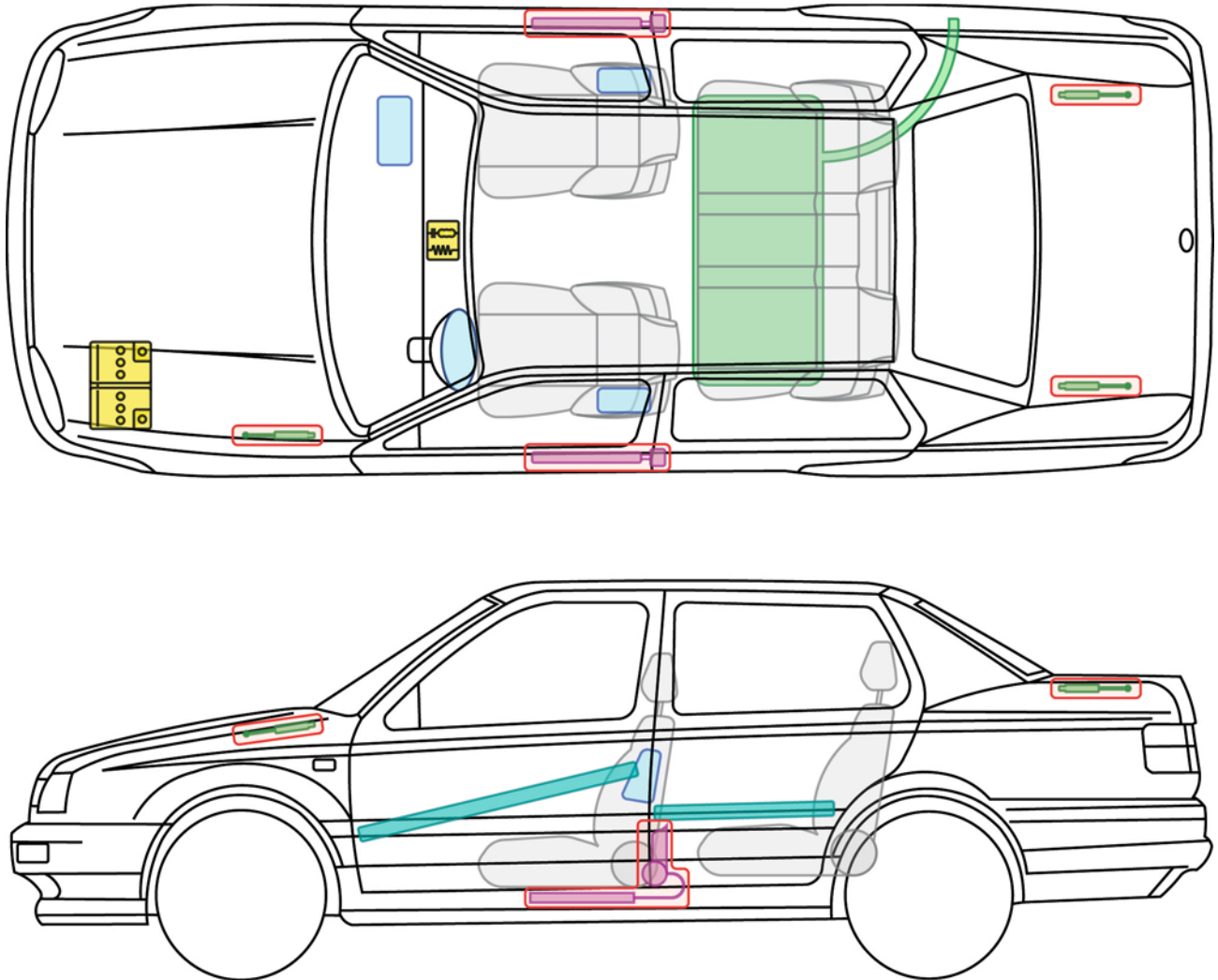

Vento

(1992 - 1998)

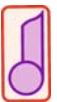

Legende

	Airbag		Karosserie-Verstärkung		Steuergerät	
					12 V-Batterie	
	Gurtstraffer		Gasdruck-dämpfer		Kraftstofftank	

V

Vento (1992 - 1998)